

COVERSHEET

Planned document changes:

Briefly:

 No planned changes.

Document changes:

Date:	Change:	Rev. after change:
2026-04-07	QS50 updated, photos replaced. ECO hose kit updated.	J
2024-08-12	ss10 (DC2/SVAB) & ss9 ECO blocks updated. DC3 cable updated.	I
2024-03-04	DC3 added.	H
2023-08-18	Cables replaced.	G
2023-02-14	New ECO std. configurations from 2023.	F
2021-10-04	Part no for lubrication kit corrected.	E
2020-05-07	ECO couplings replaced. DC2 option 5hyd added.	D
2020-01-16	Spare parts and cover updated.	C
2019-12-10	ECO50 W transport protection added.	B
2019-11-22	ECO ePS cables added. Spare parts added.	A
2018-08-15	New document.	-

Readers note:
 Indicates instruction.

 Represents Hose.

Dashed lines for overview, mounts
on other pages/assemblies.

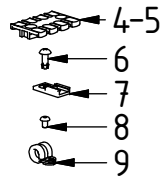

Without EC-Oil

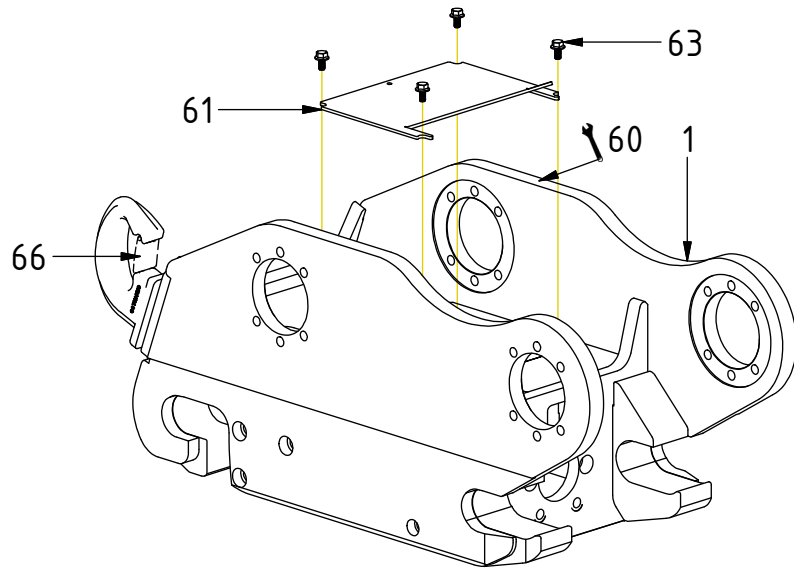
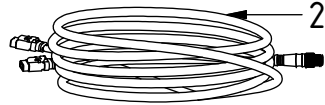

POS	DESCRIPTION	PART	QTY	COMMENTS
1	Machine hitch is selected via engcon			(Machine dependent)
2	Cable QS - QLM - Quick hitch	842149	1	Attach to QS sensors
4	Strain relief plate ZL60	8000703	1	For QS50
5	Strain relief plate ZL87	8000704	2	QTY: 1 for QS50
6	Blind rivet 4,0x12,3 DIN7337	6000294	10	
7	Holder Deutsch coupling	810662	6	
8	Screw K6S M5x8 10.9 FZB	611801	2	
9	Rubber steel clamp ø10	6000003	2	
60	Punch serial number into hitch			
61	Cover QS45/50 V3	1053624	1	
63	Screw M6SF 8x12H Riffled	6000120	4	
66	Safety latch	404250	1	Lifting hook spare part

POS in order of assembly

Hoses

POS	DESCRIPTION	PART	QTY	COMMENTS
10	Washer GBR04 1/4	710702	2	
11	Adapter 138-04-29 (1/4")	710135	2	
12	Hose Lock	741505	2	
13	Hose Lock - Liebherr	7000560	2	
14	Hose Lock - Lännen	7000561	2	
15	Hose Lock - Huddig	7001484	2	

POS in order of assembly

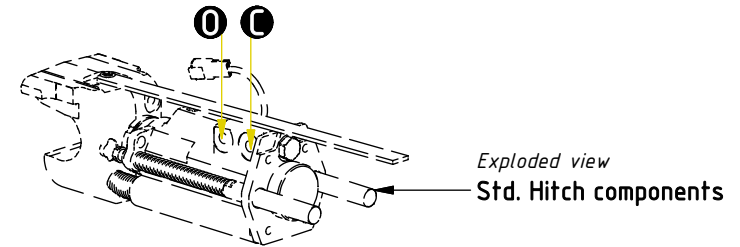
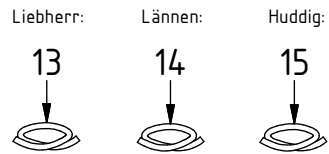
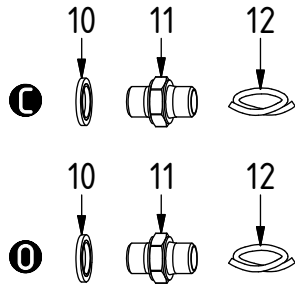

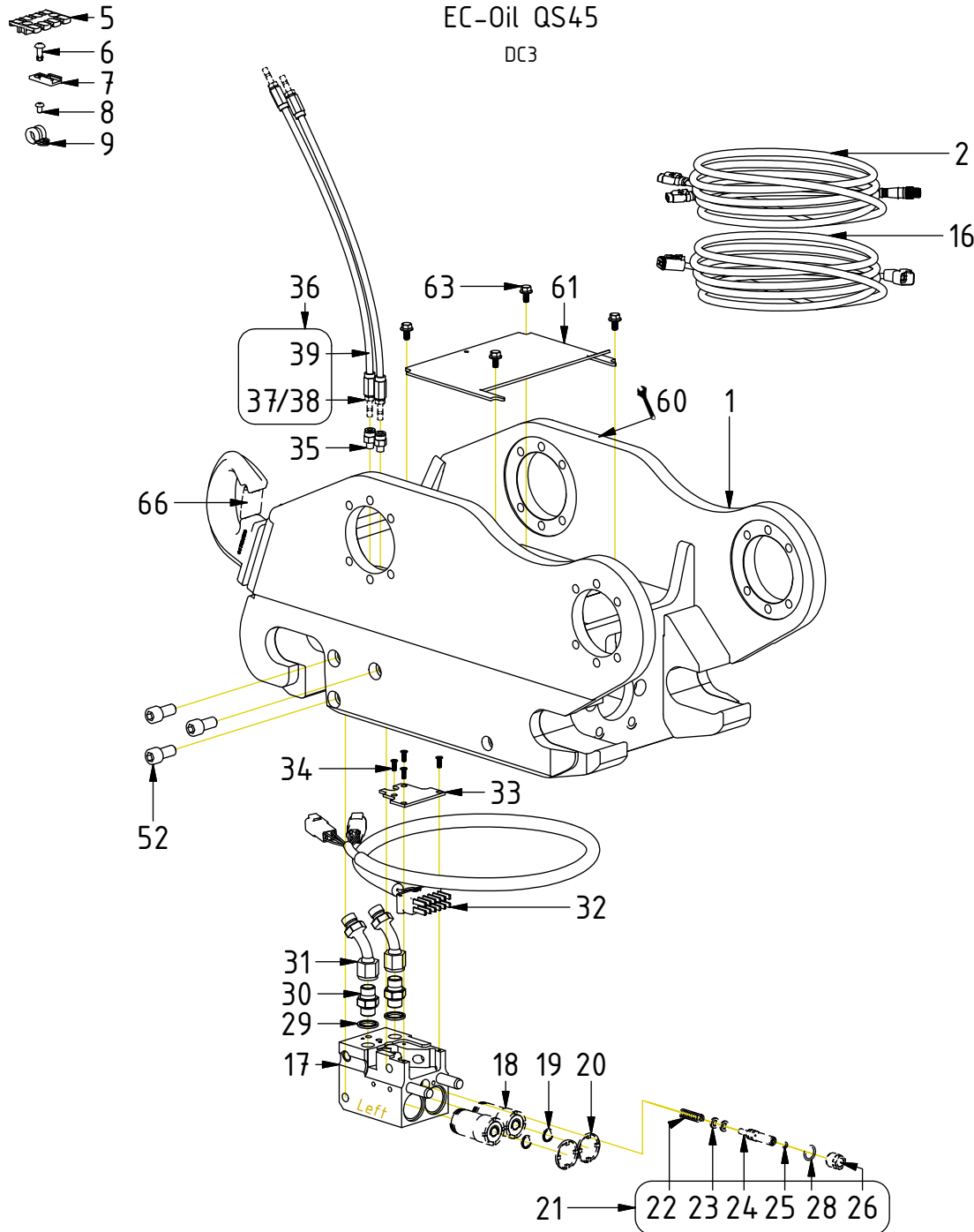

POS	DESCRIPTION	PART	QTY	COMMENTS
1	Machine hitch is selected via engcon			(Machine dependent)
2	Cable QS - QLM - Quick hitch	842149	1	Attach to QS sensors
5	Strain relief plate ZL87	8000704	2	QTY: 1 for QS50
6	Blind rivet 4,0x12,3 DIN7337	6000294	10	
7	Holder Deutsch coupling	810662	6	
8	Screw K6S M5x8 10.9 FZB	611801	2	
9	Rubber steel clamp ø10	6000003	2	
16	Cable ECO W DC3 3m (4S, 4P)	8002297	1	Attach to 4P
17	Block ECO45W Hitch 2hy,1cl. Compl.	1074021	2	(POS.18, 20-21 incl.)
18	Coupling ECO W 3/8" V3	1053029	2	Torque: 60Nm. (POS.19 incl.)
19	Flat sealing for ECO W 3/8" V3	1052976	2	
20	Dirt protection block ECO 3/8"	1028274	2	
21	Lubrication kit ECO W	1050794	1	(POS.22-28 incl.)
22	Spring 6058	1024113	1	
23	Piston sealing KPOR130 12x7,1x2,2	1024112	2	(O-ring included with seal ring)
24	Grease piston	1024111	1	
25	O-ring 3,69x1,78	1024115	1	
26	Nut grease piston	1047688	1	Wrap with thread sealing tape
27	O-ring 9,25x1,78	712429	1	Located inside POS.26
28	O-ring 14x2	7000767	1	
29	Washer GBR06 3/8	710703	2	
30	Adapter 136-06-06 (3/8")	710106	2	
31	Adapter 489-06-06 45° (3/8")	710164	2	Loxeal 55-02
32	Power plug ECO W Hitch (4P, 6P)	8002149	1	
33	Coverplate block ECO45 W Hitch	1074695	1	
34	Screw MKFT 4x12	6000121	4	
35	Straight Push-in M8x1	790185	2	
36	Hose kit - lubricant ECO W	7000514	1	(POS.37-39 incl.)
37	Push-In Tube sleeve straight 20mm	7001521	2	Depends on the specific hitch model
38	Push-In Tube sleeve 45° 15mm	7001980	2	Depends on the specific hitch model
39	Hose 2m - lubricant ECO	790176	2	
52	Screw MC6S M12x25 12.9 ZFSLH	6000164	3	Loxeal 83-52. Torque 136Nm
60	Punch serial number into hitch			
61	Cover QS45/50 V3	1053624	1	
63	Screw M6SF 8x12H Riffled	6000120	4	
64	Transport Protection ECO45-Block	1047812	1	Part of make up
66	Safety latch	404250	1	Lifting hook spare part

POS in order of assembly

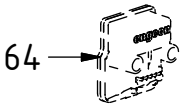

- 5
- 6
- 7
- 8
- 9

EC-Oil QS45
DC2 Std. config.

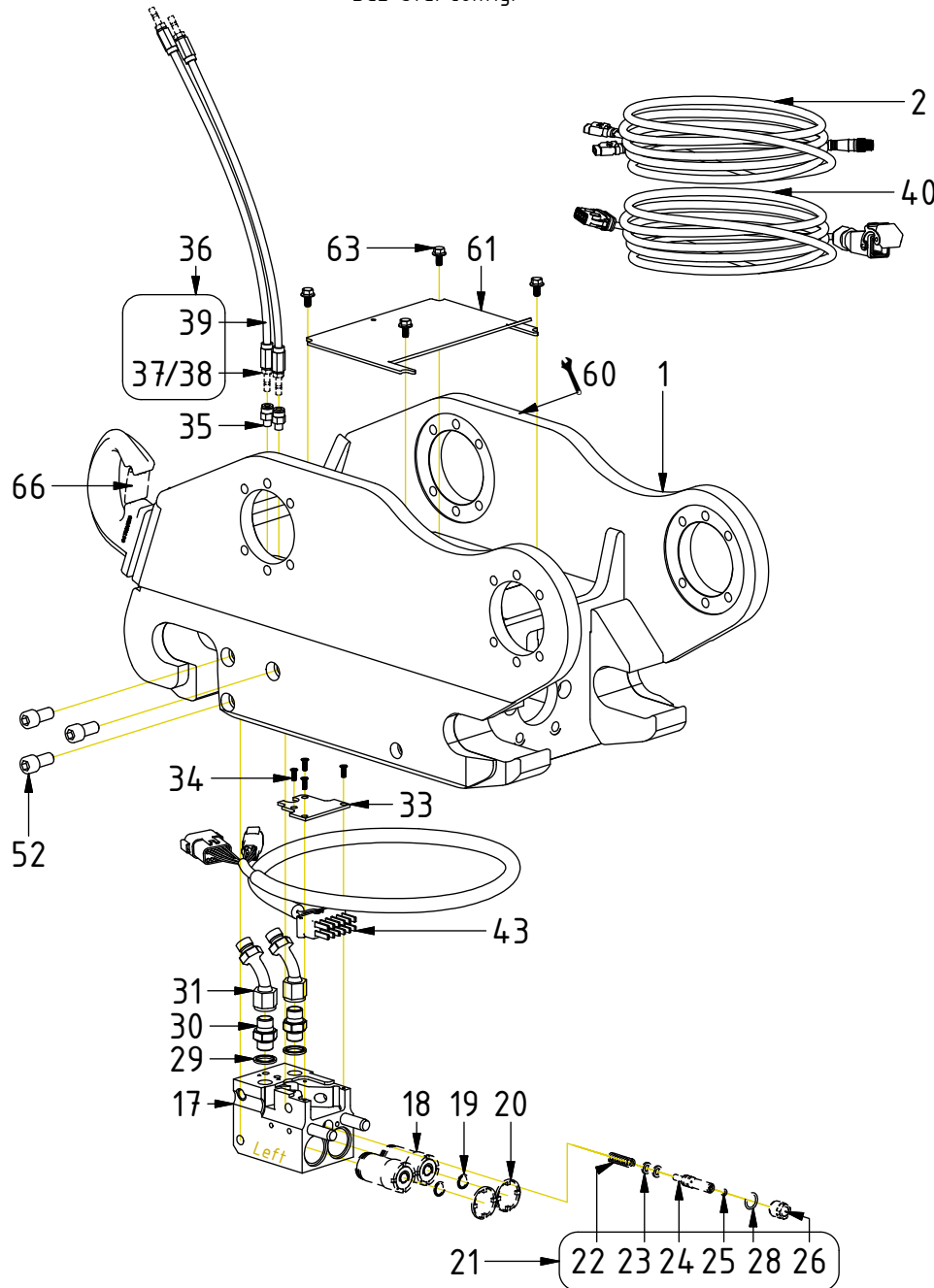

POS	DESCRIPTION	PART	QTY	COMMENTS
1	Machine hitch is selected via engcon			(Machine dependent)
2	Cable QS - QLM - Quick hitch	842149	1	Attach to QS sensors
5	Strain relief plate ZL87	8000704	2	QTY: 1 for QS50
6	Blind rivet 4,0x12,3 DIN7337	6000294	10	
7	Holder Deutsch coupling	810662	6	
8	Screw K6S M5x8 10.9 FZB	611801	2	
9	Rubber steel clamp ø10	6000003	2	
17	Block ECO45W Hitch 2hy.1cl. Compl.	1074021	2	(POS.18, 20-21 incl.)
18	Coupling ECO W 3/8" V3	1053029	2	Torque: 60Nm. (POS.19 incl.)
19	Flat sealing for ECO W 3/8" V3	1052976	2	
20	Dirt protection block ECO 3/8"	1028274	2	
21	Lubrication kit ECO W	1050794	1	(POS.22-28 incl.)
22	Spring 6058	1024113	1	
23	Piston sealing KPOR130 12x7,1x2,2	1024112	2	(O-ring included with seal ring)
24	Grease piston	1024111	1	
25	O-ring 3,69x1,78	1024115	1	
26	Nut grease piston	1047688	1	Wrap with thread sealing tape
27	O-ring 9,25x1,78	712429	1	Located inside POS.26
28	O-ring 14x2	7000767	1	
29	Washer GBR06 3/8	710703	2	
30	Adapter 136-06-06 (3/8")	710106	2	
31	Adapter 489-06-06 45° (3/8")	710164	2	Loxal 55-02
33	Coverplate block ECO45 W Hitch	1074695	1	
34	Screw MKFT 4x12	6000121	4	
35	Straight Push-in M8x1	790185	2	
36	Hose kit - lubricant ECO W	7000514	1	(POS.37-39 incl.)
37	Push-In Tube sleeve straight 20mm	7001521	2	Depends on the specific hitch model
38	Push-In Tube sleeve 45° 15mm	7001980	2	Depends on the specific hitch model
39	Hose 2m - lubricant ECO	790176	2	
40	Machine cable ECO45/50 W DC2	1048527	1	Attach to 12P
43	Power plug ECO W Hitch (12P, 6P)	1042244	1	Cable gland torque: 6Nm
52	Screw MC6S M12x25 12.9 ZFSL	6000164	3	Loxal 83-52. Torque 136Nm
60	Punch serial number into hitch			
61	Cover QS45/50 V3	1053624	1	
63	Screw M6SF 8x12H Riffled	6000120	4	
64	Transport Protection ECO45-Block	1047812	1	Part of make up
66	Safety latch	404250	1	Lifting hook spare part

POS in order of assembly

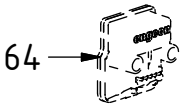

- 5
- 6
- 7
- 8
- 9

EC-Oil QS45
DC2 Option 2bl.

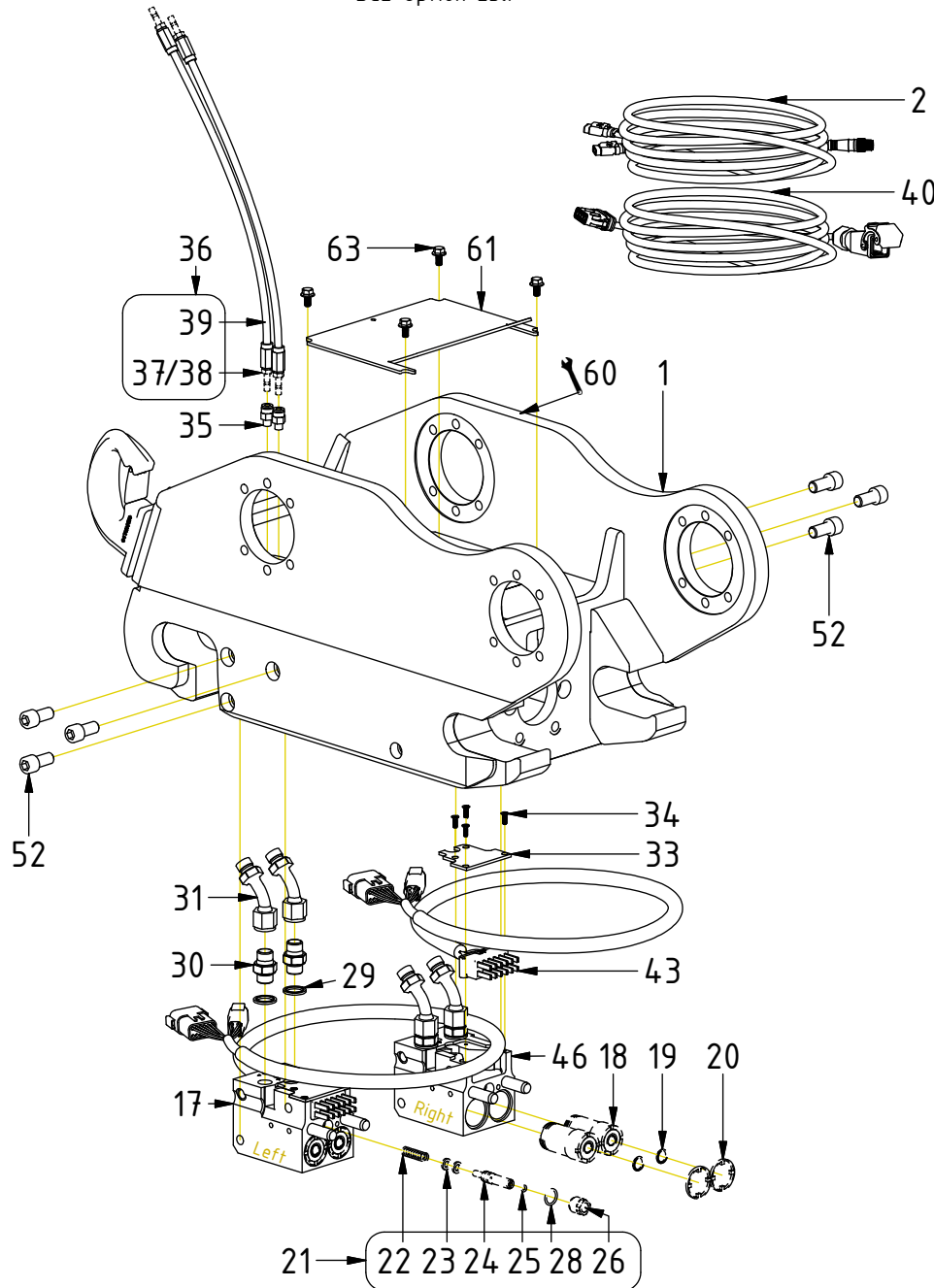

POS	DESCRIPTION	PART	QTY	COMMENTS
1	Machine hitch is selected via engcon			(Machine dependent)
2	Cable QS - QLM - Quick hitch	842149	1	Attach to QS sensors
5	Strain relief plate ZL87	8000704	2	QTY: 1 for QS50
6	Blind rivet 4,0x12,3 DIN7337	6000294	10	
7	Holder Deutsch coupling	810662	6	
8	Screw K6S M5x8 10.9 FZB	611801	2	
9	Rubber steel clamp ø10	6000003	2	
10	Washer GBR04 1/4	710702	2	
11	Adapter 138-04-29 (1/4")	710135	2	
17	Block ECO45W Hitch 2hy.1cl. Compl.	1074021	2	(POS.18, 20-21 incl.)
18	Coupling ECO W 3/8" V3	1053029	2	Torque: 60Nm. (POS.19 incl.)
19	Flat sealing for ECO W 3/8" V3	1052976	2	
20	Dirt protection block ECO 3/8"	1028274	2	
21	Lubrication kit ECO W	1050794	1	(POS.22-28 incl.)
22	Spring 6058	1024113	1	
23	Piston sealing KPOR130 12x7,1x2,2	1024112	2	(O-ring included with seal ring)
24	Grease piston	1024111	1	
25	O-ring 3,69x1,78	1024115	1	
26	Nut grease piston	1047688	1	Wrap with thread sealing tape
27	O-ring 9,25x1,78	712429	1	Located inside POS.26
28	O-ring 14x2	7000767	1	
29	Washer GBR06 3/8	710703	2	
30	Adapter 136-06-06 (3/8")	710106	2	
31	Adapter 489-06-06 45° (3/8")	710164	2	Loxeal 55-02
33	Coverplate block ECO45 W Hitch	1074695	1	
34	Screw MKFT 4x12	6000121	4	
35	Straight Push-in M8x1	790185	2	
36	Hose kit - lubricant ECO W	7000514	1	(POS.37-39 incl.)
37	Push-In Tube sleeve straight 20mm	7001521	2	Depends on the specific hitch model
38	Push-In Tube sleeve 45° 15mm	7001980	2	Depends on the specific hitch model
39	Hose 2m - lubricant ECO	790176	2	
40	Machine cable ECO45/50 W DC2	1048527	1	Attach to Left 12P
43	Power plug ECO W Hitch (12P, 6P)	1042244	1	Cable gland torque: 6Nm
46	Block ECO45W Hitch 2hy. Complete	1076524	1	(POS.18, 20 incl.)
47	Block ECO45W Hitch 3hy. Complete	1054417	1	(POS.18, 20, 48, 50 incl.)
48	Coupling ECO 1/4" V3	1053683	1	Torque 60Nm. (POS.49 incl.)
49	Flat sealing for ECO 1/4" V3	1053936	1	
50	Dirt protection block ECO 1/4"	1054419	1	
51	Adapter 489-04-04 45° (1/4")	710163	1	
52	Screw MC6S M12x25 12.9 ZFSLH	6000164	3	Loxeal 83-52. Torque 136Nm
60	Punch serial number into hitch			
61	Cover QS45/50 V3	1053624	1	
63	Screw M6SF 8x12H Riffled	6000120	4	

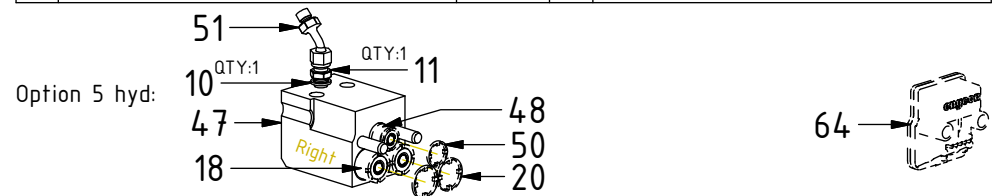

POS in order of assembly

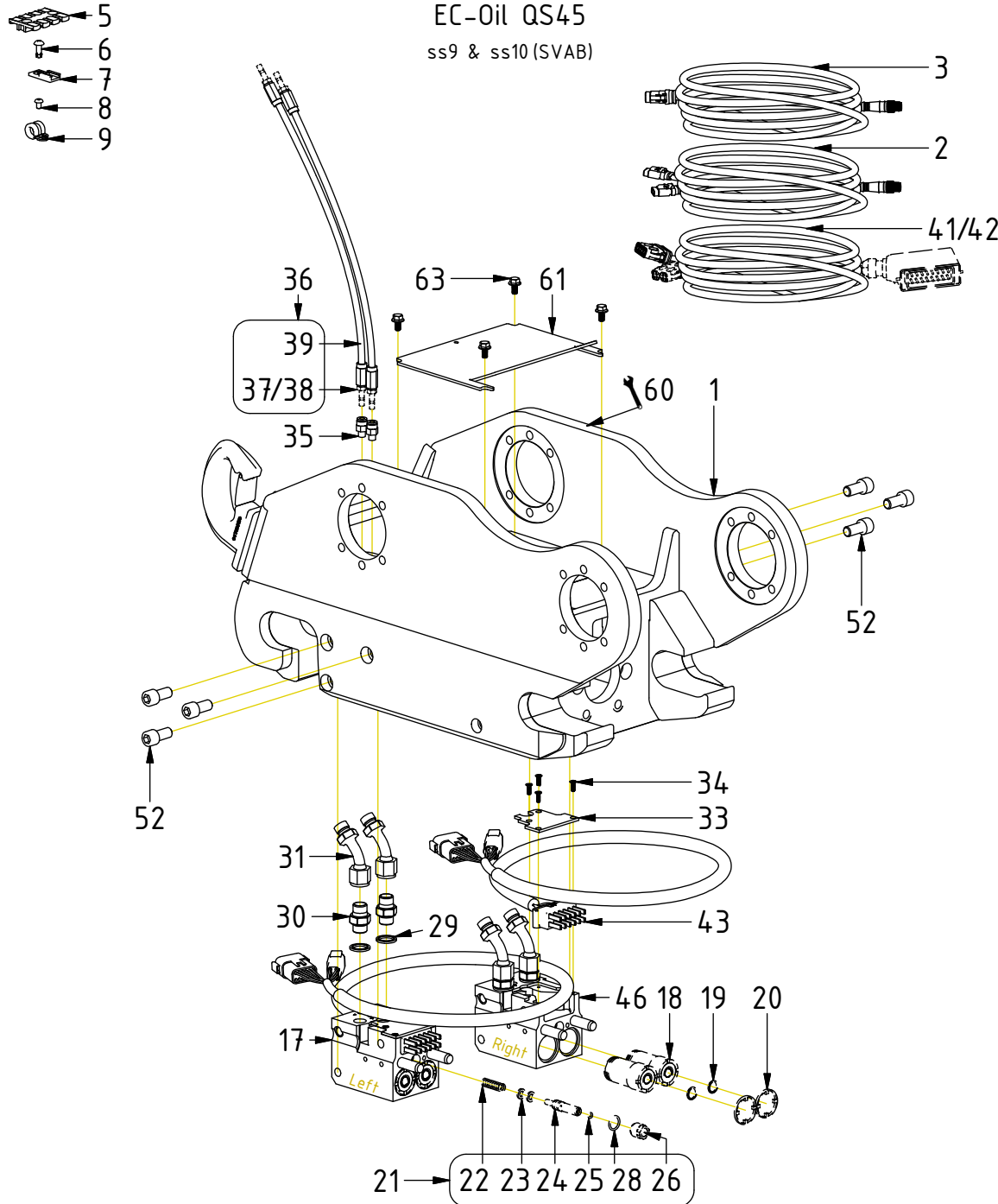

POS	DESCRIPTION	PART	QTY	COMMENTS
1	Machine hitch is selected via engcon			(Machine dependent)
2	Cable QS - QLM - Quick hitch	842149	1	Attach to QS sensors
3	Cable QS - QLM - Tilt rotator	842148	1	Attach to Left 6P
5	Strain relief plate ZL87	8000704	2	QTY: 1 for QS50
6	Blind rivet 4,0x12,3 DIN7337	6000294	10	
7	Holder Deutsch coupling	810662	6	
8	Screw K6S M5x8 10.9 FZB	611801	2	
9	Rubber steel clamp ø10	6000003	2	
17	Block ECO45W Hitch 2hy,1cl. Compl.	1074021	2	(POS.18, 20-21 incl.)
18	Coupling ECO W 3/8" V3	1053029	2	Torque: 60Nm. (POS.19 incl.)
19	Flat sealing for ECO W 3/8" V3	1052976	2	
20	Dirt protection block ECO 3/8"	1028274	2	
21	Lubrication kit ECO W	1050794	1	(POS.22-28 incl.)
22	Spring 6058	1024113	1	
23	Piston sealing KPOR130 12x7,1x2,2	1024112	2	(O-ring included with seal ring)
24	Grease piston	1024111	1	
25	O-ring 3,69x1,78	1024115	1	
26	Nut grease piston	1047688	1	Wrap with thread sealing tape
27	O-ring 9,25x1,78	712429	1	Located inside POS.26
28	O-ring 14x2	7000767	1	
29	Washer GBR06 3/8	710703	2	
30	Adapter 136-06-06 (3/8")	710106	2	
31	Adapter 489-06-06 45° (3/8")	710164	2	Loxéal 55-02
33	Coverplate block ECO45 W Hitch	1074695	1	
34	Screw MKFT 4x12	6000121	4	
35	Straight Push-in M8x1	790185	2	
36	Hose kit - lubricant ECO W	7000514	1	(POS.37-39 incl.)
37	Push-In Tube sleeve straight 20mm	7001521	2	Depends on the specific hitch model
38	Push-In Tube sleeve 45° 15mm	7001980	2	Depends on the specific hitch model
39	Hose 2m - lubricant ECO	790176	2	
41	Machinecable ECO W ss9-2 (1x 12P)	1036844	1	Attach to Left 12P
42	Machinecable ECO W SVAB (2x 12P)	8002008	1	Attach to both 12P
43	Power plug ECO W Hitch (12P, 6P)	1042244	1	Cable gland torque: 6Nm
46	Block ECO45W Hitch 2hy. Complete	1076524	1	(POS.18, 20 incl.)
52	Screw MC6S M12x25 12.9 ZFSLH	6000164	3	Loxéal 83-52. Torque 136Nm
59	Cable ePS ECO W ss9,ss10(SVAB)	1042246	1	Attach to Right 6P
60	Punch serial number into hitch			
61	Cover QS45/50 V3	1053624	1	
63	Screw M6SF 8x12H Riffled	6000120	4	
64	Transport Protection ECO45-Block	1047812	1	Part of make up

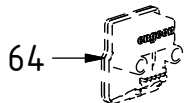
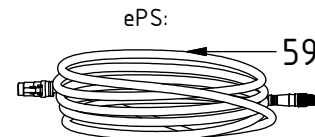

POS in order of assembly

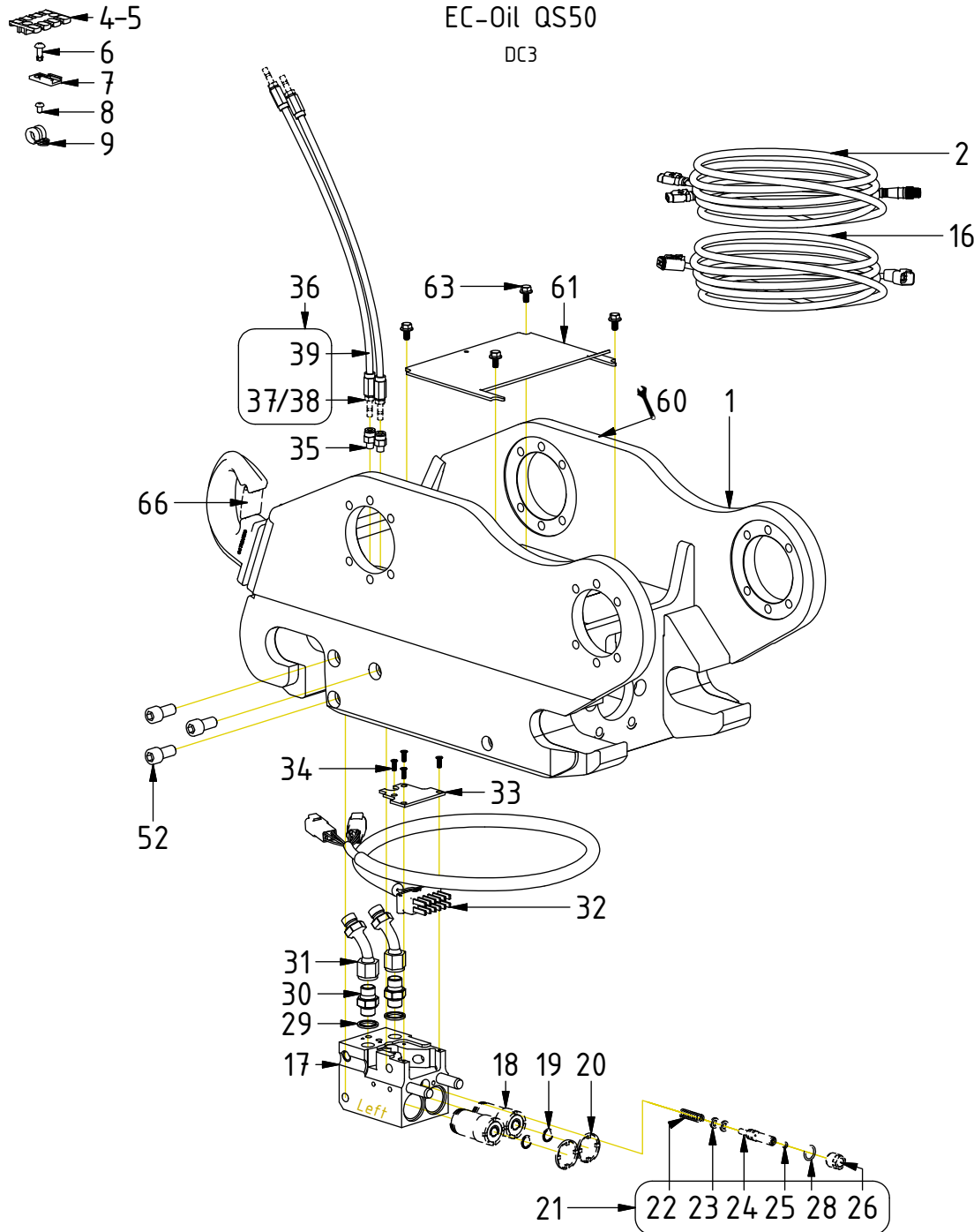

POS	DESCRIPTION	PART	QTY	COMMENTS
1	Machine hitch is selected via engcon			(Machine dependent)
2	Cable QS - QLM - Quick hitch	842149	1	Attach to QS sensors
4	Strain relief plate ZL60	8000703	1	For QS50
5	Strain relief plate ZL87	8000704	2	QTY: 1 for QS50
6	Blind rivet 4,0x12,3 DIN7337	6000294	10	
7	Holder Deutsch coupling	810662	6	
8	Screw K6S M5x8 10.9 FZB	611801	2	
9	Rubber steel clamp ø10	6000003	2	
16	Cable ECO W DC3 3m (4S, 4P)	8002297	1	Attach to 4P
17	Block ECO45W Hitch 2hy.1cl. Compl.	1074021	2	(POS.18, 20-21 incl.)
18	Coupling ECO W 3/8" V3	1053029	2	Torque: 60Nm. (POS.19 incl.)
19	Flat sealing for ECO W 3/8" V3	1052976	2	
20	Dirt protection block ECO 3/8"	1028274	2	
21	Lubrication kit ECO W	1050794	1	(POS.22-28 incl.)
22	Spring 6058	1024113	1	
23	Piston sealing KPOR130 12x7,1x2,2	1024112	2	(O-ring included with seal ring)
24	Grease piston	1024111	1	
25	O-ring 3,69x1,78	1024115	1	
26	Nut grease piston	1047688	1	Wrap with thread sealing tape
27	O-ring 9,25x1,78	712429	1	Located inside POS.26
28	O-ring 14x2	7000767	1	
29	Washer GBR06 3/8	710703	2	
30	Adapter 136-06-06 (3/8")	710106	2	
31	Adapter 489-06-06 45° (3/8")	710164	2	Loxreal 55-02
32	Power plug ECO W Hitch (4P, 6P)	8002149	1	
33	Coverplate block ECO45 W Hitch	1074695	1	
34	Screw MKFT 4x12	6000121	4	
35	Straight Push-in M8x1	790185	2	
36	Hose kit - lubricant ECO W	7000514	1	(POS.37-39 incl.)
37	Push-In Tube sleeve straight 20mm	7001521	2	Depends on the specific hitch model
38	Push-In Tube sleeve 45° 15mm	7001980	2	Depends on the specific hitch model
39	Hose 2m - lubricant ECO	790176	2	
52	Screw MC6S M12x25 12.9 ZFSL	6000164	3	Loxreal 83-52. Torque 136Nm
60	Punch serial number into hitch			
61	Cover QS45/50 V3	1053624	1	
63	Screw M6SF 8x12H Riffled	6000120	4	
64	Transport Protection ECO45-Block	1047812	1	Part of make up
66	Safety latch	404250	1	Lifting hook spare part

POS in order of assembly

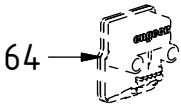

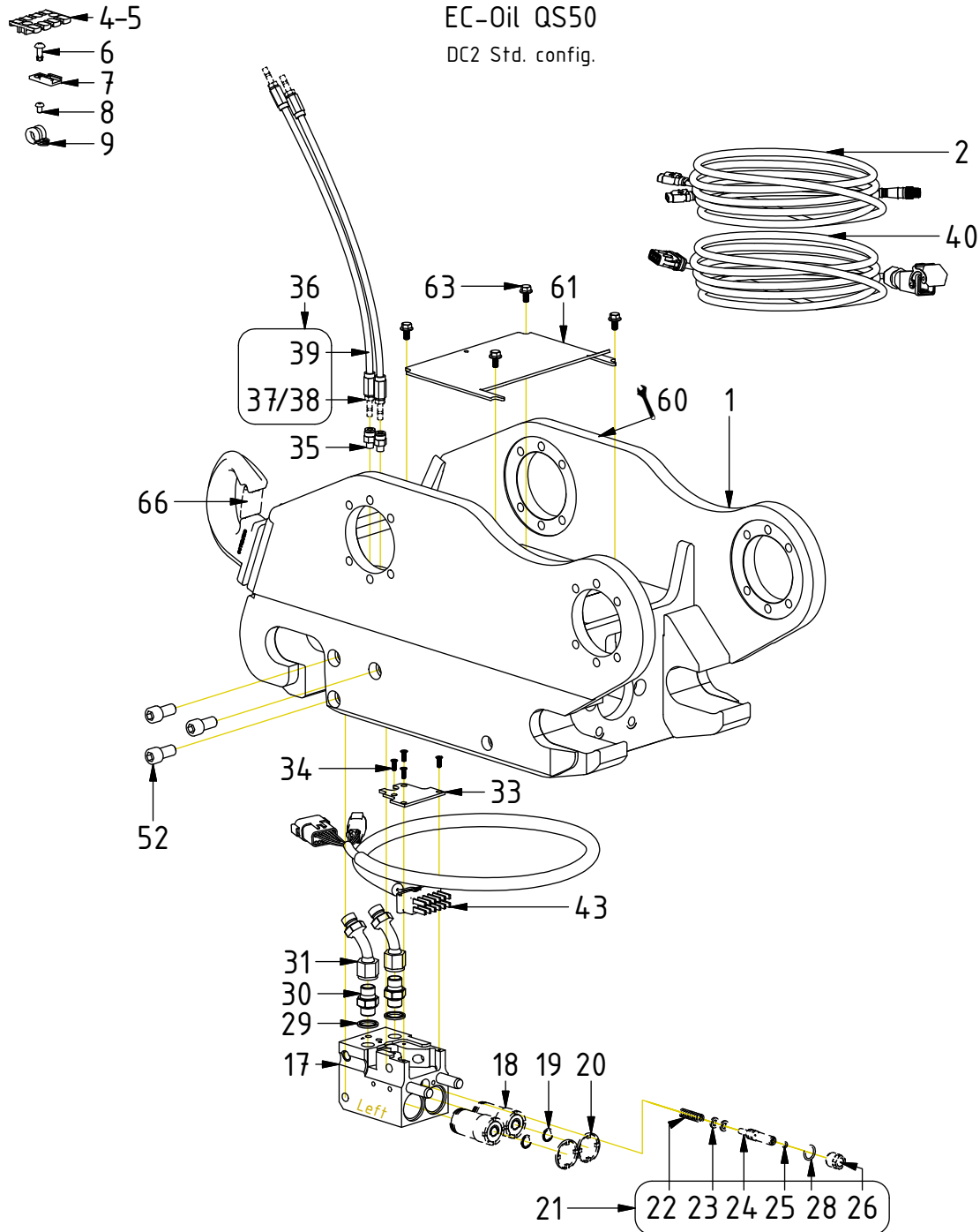

EC-Oil QS50
DC2 Std. config.

POS	DESCRIPTION	PART	QTY	COMMENTS
1	Machine hitch is selected via engcon			(Machine dependent)
2	Cable QS - QLM - Quick hitch	842149	1	Attach to QS sensors
4	Strain relief plate ZL60	8000703	1	For QS50
5	Strain relief plate ZL87	8000704	2	QTY: 1 for QS50
6	Blind rivet 4,0x12,3 DIN7337	6000294	10	
7	Holder Deutsch coupling	810662	6	
8	Screw K6S M5x8 10.9 FZB	611801	2	
9	Rubber steel clamp ø10	6000003	2	
17	Block ECO45W Hitch 2hy.1cl. Compl.	1074021	2	(POS.18, 20-21 incl.)
18	Coupling ECO W 3/8" V3	1053029	2	Torque: 60Nm. (POS.19 incl.)
19	Flat sealing for ECO W 3/8" V3	1052976	2	
20	Dirt protection block ECO 3/8"	1028274	2	
21	Lubrication kit ECO W	1050794	1	(POS.22-28 incl.)
22	Spring 6058	1024113	1	
23	Piston sealing KPOR130 12x7,1x2,2	1024112	2	(O-ring included with seal ring)
24	Grease piston	1024111	1	
25	O-ring 3,69x1,78	1024115	1	
26	Nut grease piston	1047688	1	Wrap with thread sealing tape
27	O-ring 9,25x1,78	712429	1	Located inside POS.26
28	O-ring 14x2	7000767	1	
29	Washer GBR06 3/8	710703	2	
30	Adapter 136-06-06 (3/8")	710106	2	
31	Adapter 489-06-06 45° (3/8")	710164	2	Loxeal 55-02
33	Coverplate block ECO45 W Hitch	1074695	1	
34	Screw MKFT 4x12	6000121	4	
35	Straight Push-in M8x1	790185	2	
36	Hose kit - lubricant ECO W	7000514	1	(POS.37-39 incl.)
37	Push-In Tube sleeve straight 20mm	7001521	2	Depends on the specific hitch model
38	Push-In Tube sleeve 45° 15mm	7001980	2	Depends on the specific hitch model
39	Hose 2m - lubricant ECO	790176	2	
40	Machine cable ECO45/50 W DC2	1048527	1	Attach to 12P
43	Power plug ECO W Hitch (12P, 6P)	1042244	1	Cable gland torque: 6Nm
52	Screw MC6S M12x25 12.9 ZFSL	6000164	3	Loxeal 83-52. Torque 136Nm
60	Punch serial number into hitch			
61	Cover QS45/50 V3	1053624	1	
63	Screw M6SF 8x12H Riffled	6000120	4	
64	Transport Protection ECO45-Block	1047812	1	Part of make up
66	Safety latch	404250	1	Lifting hook spare part

POS in order of assembly

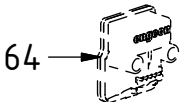

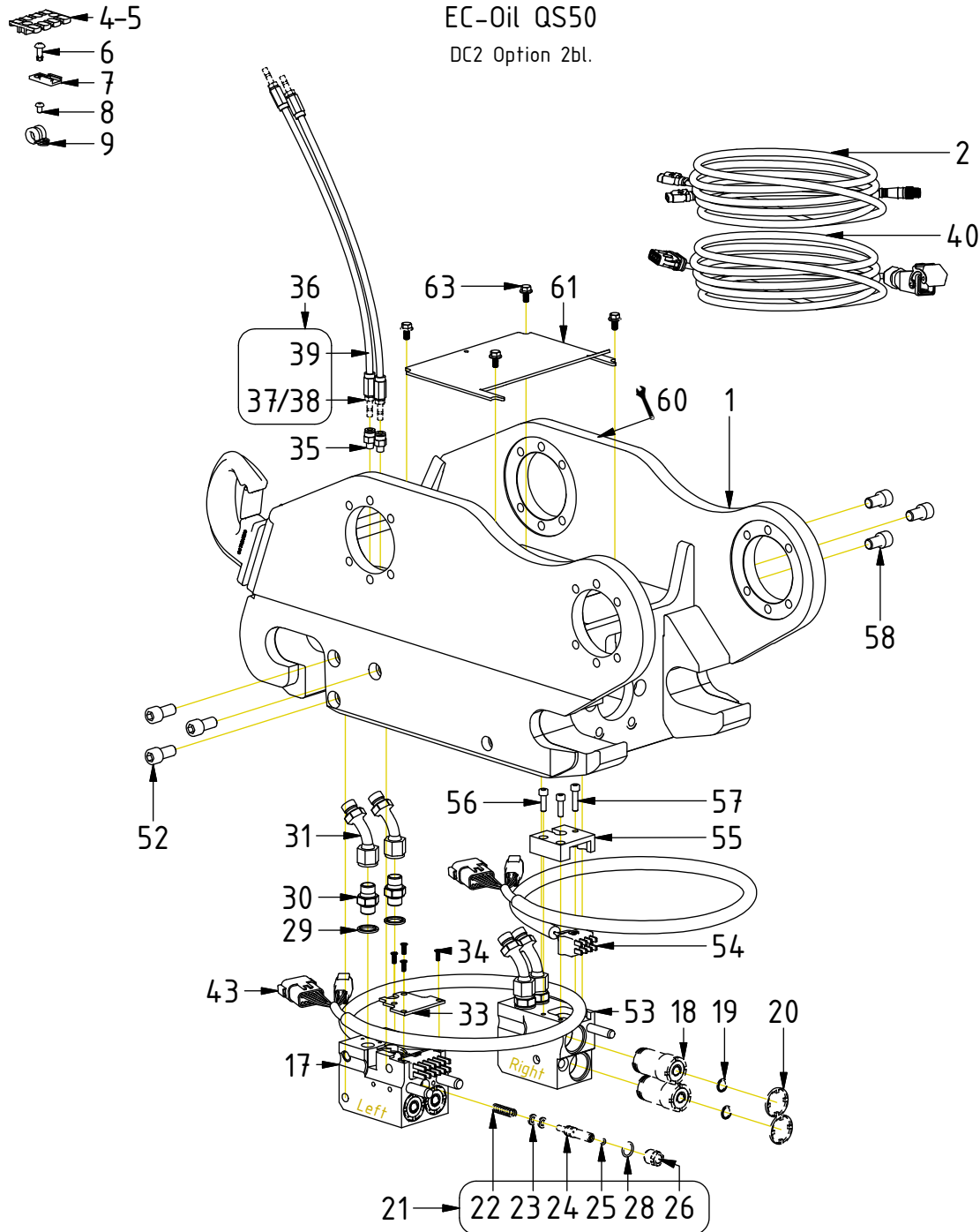

POS	DESCRIPTION	PART	QTY	COMMENTS
1	Machine hitch is selected via engcon			(Machine dependent)
2	Cable QS - QLM - Quick hitch	842149	1	Attach to QS sensors
4	Strain relief plate ZL60	8000703	1	For QS50
5	Strain relief plate ZL87	8000704	2	QTY: 1 for QS50
6	Blind rivet 4,0x12,3 DIN7337	6000294	10	
7	Holder Deutsch coupling	810662	6	
8	Screw K6S M5x8 10.9 FZB	611801	2	
9	Rubber steel clamp ø10	6000003	2	
17	Block ECO45W Hitch 2hy,1cl. Compl.	1074021	2	(POS.18, 20-21 incl.)
18	Coupling ECO W 3/8" V3	1053029	2	Torque: 60Nm. (POS.19 incl.)
19	Flat sealing for ECO W 3/8" V3	1052976	2	
20	Dirt protection block ECO 3/8"	1028274	2	
21	Lubrication kit ECO W	1050794	1	(POS.22-28 incl.)
22	Spring 6058	1024113	1	
23	Piston sealing KPOR130 12x7,1x2,2	1024112	2	(O-ring included with seal ring)
24	Grease piston	1024111	1	
25	O-ring 3,69x1,78	1024115	1	
26	Nut grease piston	1047688	1	Wrap with thread sealing tape
28	O-ring 14x2	7000767	1	
29	Washer GBR06 3/8	710703	2	
30	Adapter 136-06-06 (3/8")	710106	2	
31	Adapter 489-06-06 45° (3/8")	710164	2	Loxeal 55-02
33	Coverplate block ECO45 W Hitch	1074695	1	
34	Screw MKFT 4x12	6000121	4	
35	Straight Push-in M8x1	790185	2	
36	Hose kit - lubricant ECO W	7000514	1	(POS.37-39 incl.)
37	Push-In Tube sleeve straight 20mm	7001521	2	Depends on the specific hitch model
38	Push-In Tube sleeve 45° 15mm	7001980	2	Depends on the specific hitch model
39	Hose 2m - lubricant ECO	790176	2	
40	Machine cable ECO45/50 W DC2	1048527	1	Attach to Left 12P
43	Power plug ECO W Hitch (12P, 6P)	1042244	1	Cable gland torque: 6Nm
52	Screw MC6S M12x25 12.9 ZFSL	6000164	3	Loxeal 83-52. Torque 136Nm
53	Block ECO50W Hitch 2hy. Complete	1055714	1	(POS.18, 20 incl.)
54	Power plug ECO50 W Hitch (QSM)	8002007	1	Cable gland torque: 6Nm
55	Coverplate block ECO50 W Hitch	1041647	1	
56	Screw MC6S M6x20 12.9	610414	2	
57	Screw MC6S M6x25 12.9	6000083	1	
58	Screw MC6S M12x20 12.9	610472	3	Loxeal 83-52
60	Punch serial number into hitch			
61	Cover QS45/50 V3	1053624	1	
63	Screw M6SF 8x12H Riffled	6000120	4	
64	Transport Protection ECO45-Block	1047812	1	Part of make up
65	Transport Protection ECO50-Block	1049167	2	Part of make up



POS in order of assembly

Machine hitch - QS45/QS50

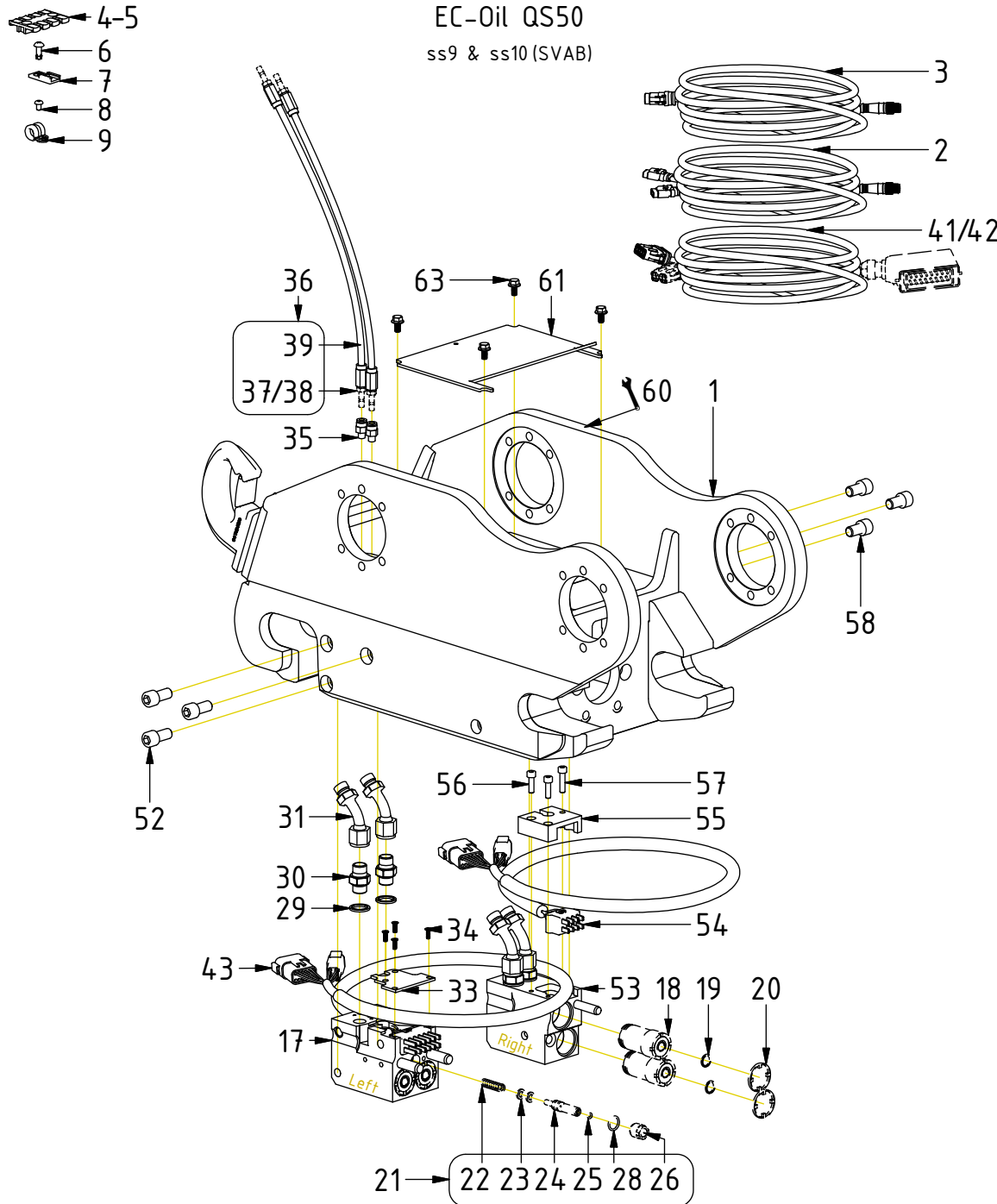

POS	DESCRIPTION	PART	QTY	COMMENTS
1	Machine hitch is selected via engcon			(Machine dependent)
2	Cable QS - QLM - Quick hitch	842149	1	Attach to QS sensors
3	Cable QS - QLM - Tilt rotator	842148	1	Attach to Left 6P
4	Strain relief plate ZL60	8000703	1	For QS50
5	Strain relief plate ZL87	8000704	2	QTY: 1 for QS50
6	Blind rivet 4,0x12,3 DIN7337	6000294	10	
7	Holder Deutsch coupling	810662	6	
8	Screw K6S M5x8 10.9 FZB	611801	2	
9	Rubber steel clamp ø10	6000003	2	
17	Block ECO45W Hitch 2hy.1cl. Compl.	1074021	2	(POS.18, 20-21 incl.)
18	Coupling ECO W 3/8" V3	1053029	2	Torque: 60Nm. (POS.19 incl.)
19	Flat sealing for ECO W 3/8" V3	1052976	2	
20	Dirt protection block ECO 3/8"	1028274	2	
21	Lubrication kit ECO W	1050794	1	(POS.22-28 incl.)
22	Spring 6058	1024113	1	
23	Piston sealing KPOR130 12x7,1x2,2	1024112	2	(O-ring included with seal ring)
24	Grease piston	1024111	1	
25	O-ring 3,69x1,78	1024115	1	
26	Nut grease piston	1047688	1	Wrap with thread sealing tape
28	O-ring 14x2	7000767	1	
29	Washer GBR06 3/8	710703	2	
30	Adapter 136-06-06 (3/8")	710106	2	
31	Adapter 489-06-06 45° (3/8")	710164	2	Loxal 55-02
33	Coverplate block ECO45 W Hitch	1074695	1	
34	Screw MKFT 4x12	6000121	4	
35	Straight Push-in M8x1	790185	2	
36	Hose kit - lubricant ECO W	7000514	1	(POS.37-39 incl.)
37	Push-In Tube sleeve straight 20mm	7001521	2	Depends on the specific hitch model
38	Push-In Tube sleeve 45° 15mm	7001980	2	Depends on the specific hitch model
39	Hose 2m - lubricant ECO	790176	2	
41	Machinecable ECO W ss9-2 (1x 12P)	1036844	1	Attach to Left 12P
42	Machinecable ECO W SVAB (2x 12P)	8002008	1	Attach to both 12P
43	Power plug ECO W Hitch (12P, 6P)	1042244	1	Cable gland torque: 6Nm
52	Screw MC6S M12x25 12.9 ZFSL	6000164	3	Loxal 83-52. Torque 136Nm
53	Block ECO50W Hitch 2hy. Complete	1055714	1	(POS.18, 20 incl.)
54	Power plug ECO50 W Hitch (QSM)	8002007	1	Cable gland torque: 6Nm
55	Coverplate block ECO50 W Hitch	1041647	1	
56	Screw MC6S M6x20 12.9	610414	2	
57	Screw MC6S M6x25 12.9	6000083	1	
58	Screw MC6S M12x20 12.9	610472	3	Loxal 83-52
59	Cable ePS ECO W ss9,ss10(SVAB)	1042246	1	Attach to Right 6P
61	Cover QS45/50 V3	1053624	1	
63	Screw M6SF 8x12H Riffled	6000120	4	
64	Transport Protection ECO45-Block	1047812	1	Part of make up
65	Transport Protection ECO50-Block	1049167	2	Part of make up



POS in order of assembly

Without EC-Oil
QS45:

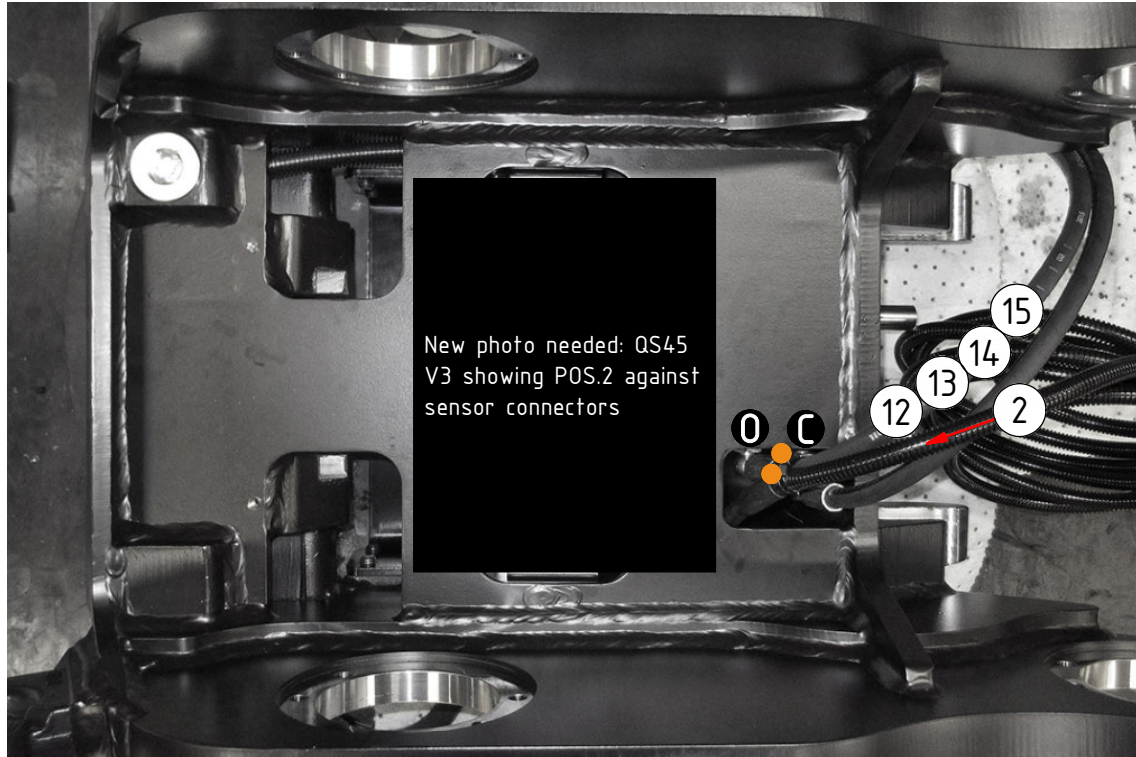

QS50:

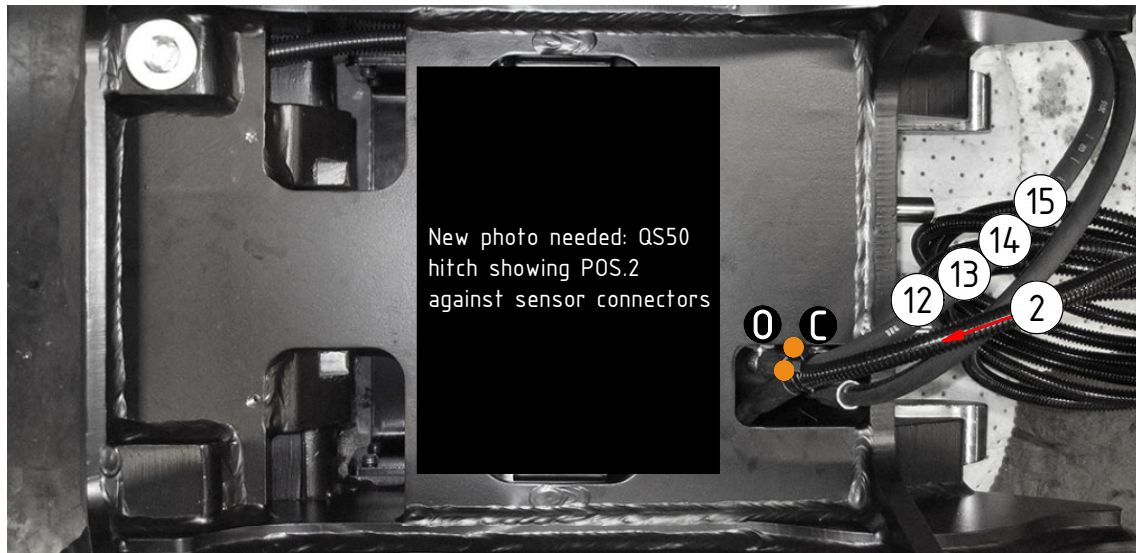

POS	DESCRIPTION	PART	QTY	COMMENTS
2	Cable QS - QLM - Quick hitch	842149	1	Attach to QS sensors
9	Rubber steel clamp ø10	6000003	2	
12	Hose Lock	741505	2	
13	Hose Lock - Liebherr	7000560	2	
14	Hose Lock - Lännen	7000561	2	
15	Hose Lock - Huddig	7001484	2	
●	Use cable ties			

POS in order of assembly

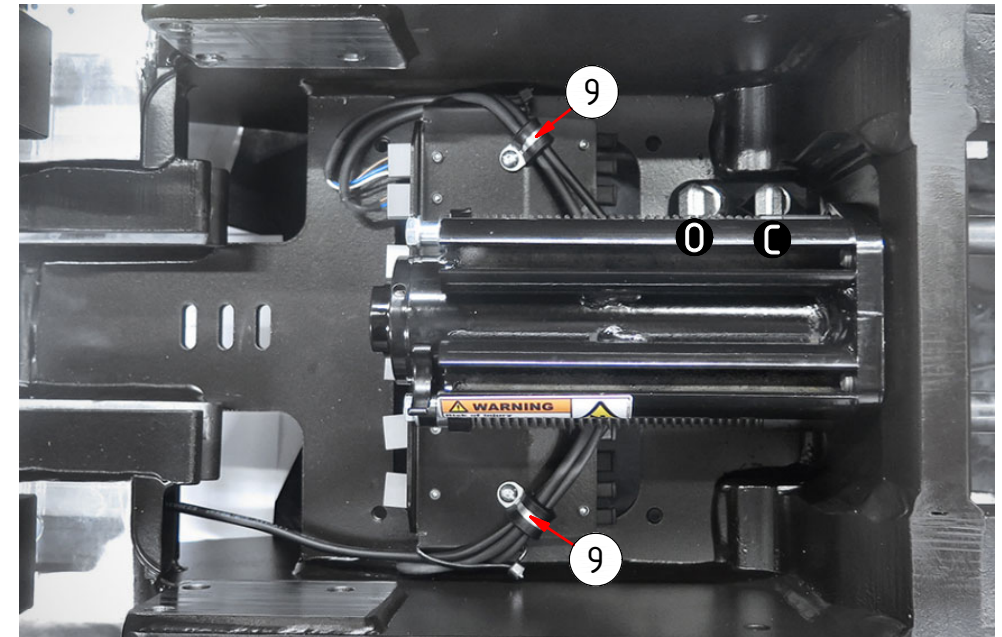

EC-Oil QS45
DC3

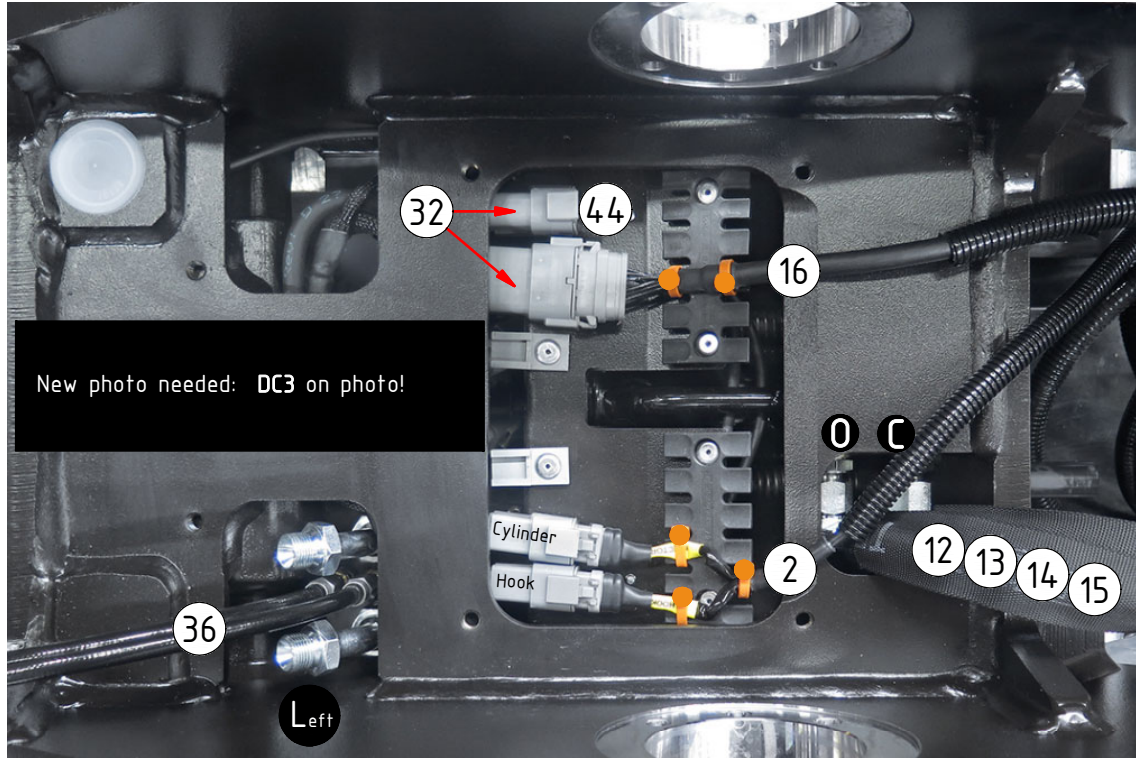

POS	DESCRIPTION	PART	QTY	COMMENTS
2	Cable QS - QLM - Quick hitch	842149	1	Attach to QS sensors
9	Rubber steel clamp ø10	6000003	2	
12	Hose Lock	741505	2	
13	Hose Lock - Liebherr	7000560	2	
14	Hose Lock - Lännen	7000561	2	
15	Hose Lock - Huddig	7001484	2	
16	Cable ECO W DC3 3m (4S, 4P)	8002297	1	Attach to 4P
32	Power plug ECO W Hitch (4P, 6P)	8002149	1	
36	Hose kit - lubricant ECO W	7000514	1	(POS.37-39 incl.)
44	Plug for 6P	8000620	1	QTY depends on config.
●	Use cable ties			

POS in order of assembly

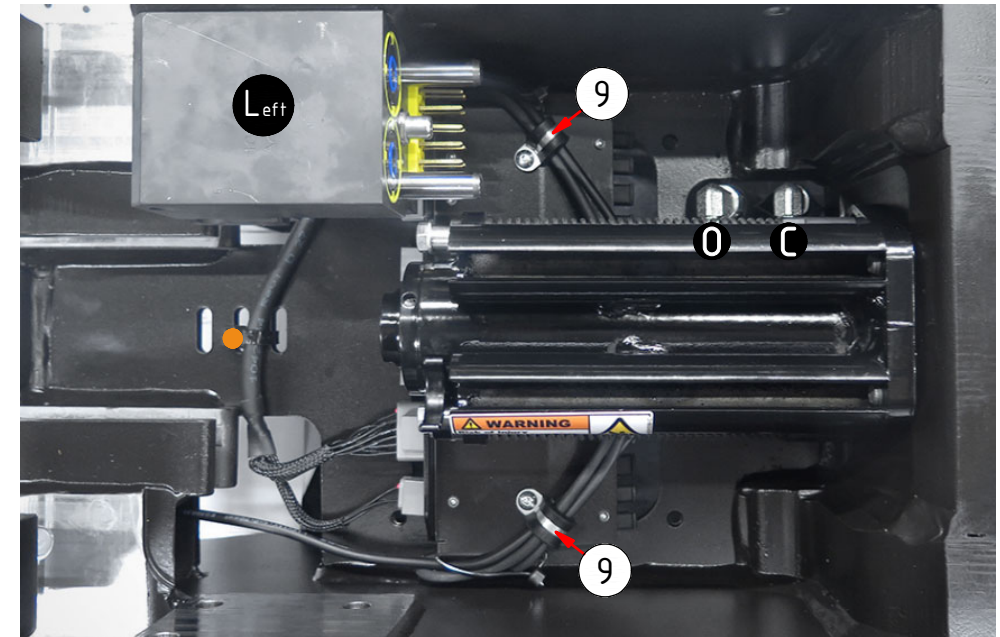

EC-Oil QS45
DC2 Std. config.

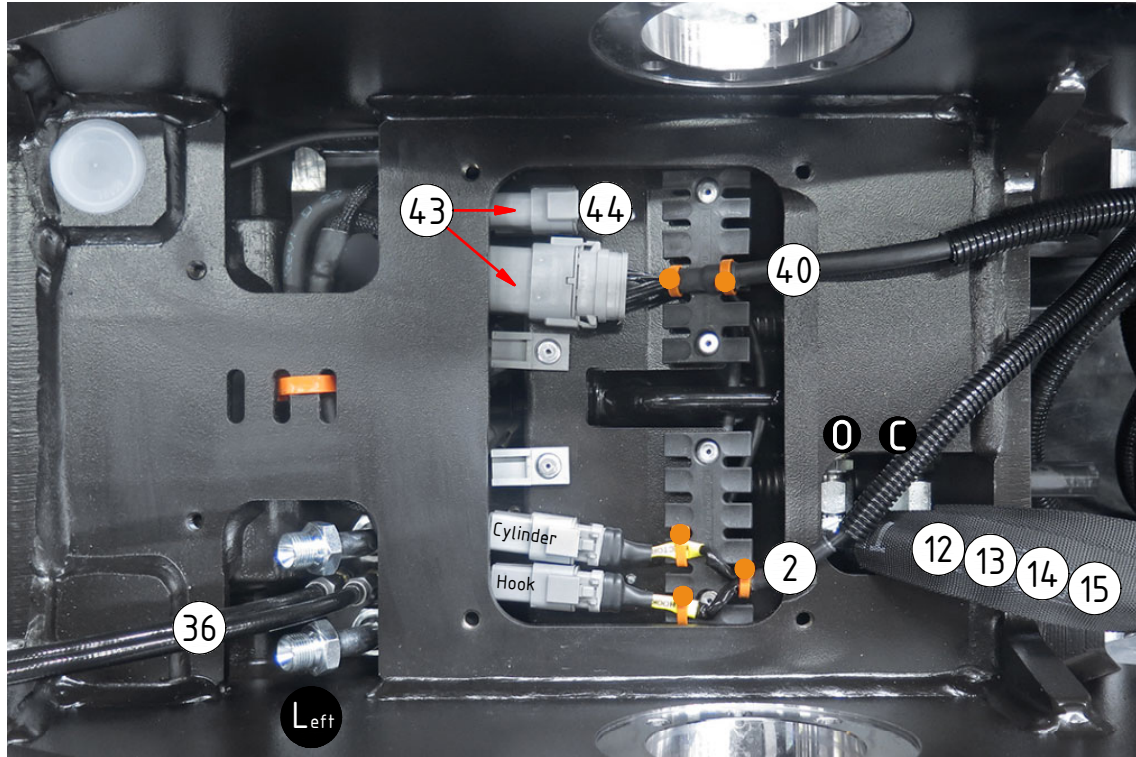

POS	DESCRIPTION	PART	QTY	COMMENTS
2	Cable QS - QLM - Quick hitch	842149	1	Attach to QS sensors
9	Rubber steel clamp \varnothing 10	6000003	2	
12	Hose Lock	741505	2	
13	Hose Lock - Liebherr	7000560	2	
14	Hose Lock - Lännen	7000561	2	
15	Hose Lock - Huddig	7001484	2	
36	Hose kit - lubricant ECO W	7000514	1	(POS.37-39 incl.)
40	Machine cable ECO45/50 W DC2	1048527	1	Attach to 12P
43	Power plug ECO W Hitch (12P, 6P)	1042244	1	Cable gland torque: 6Nm
44	Plug for 6P	8000620	1	QTY depends on config.
● Use cable ties				

POS in order of assembly

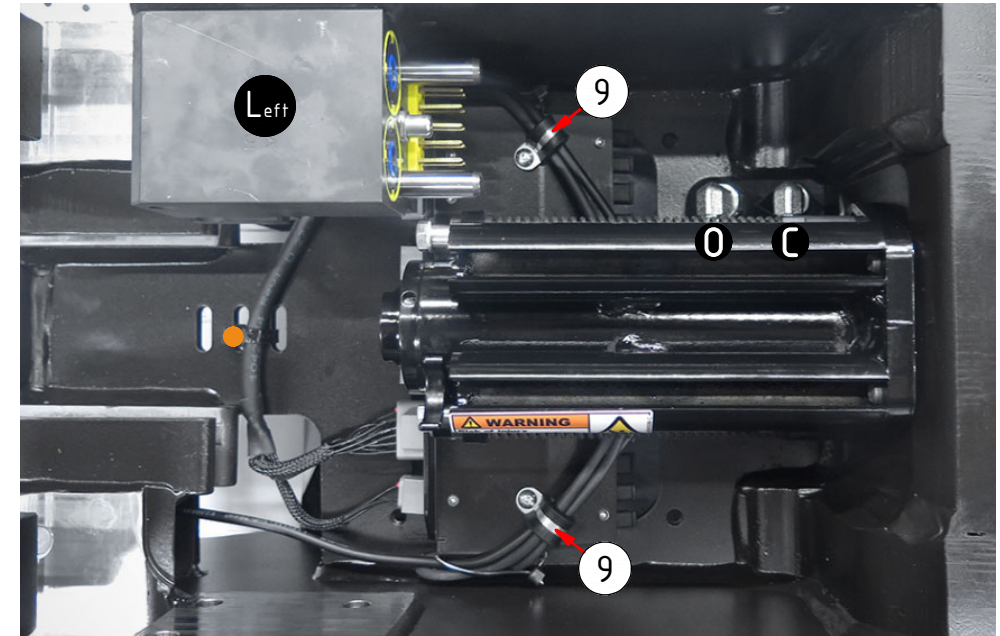

EC-Oil QS45
DC2 Option 2bl.

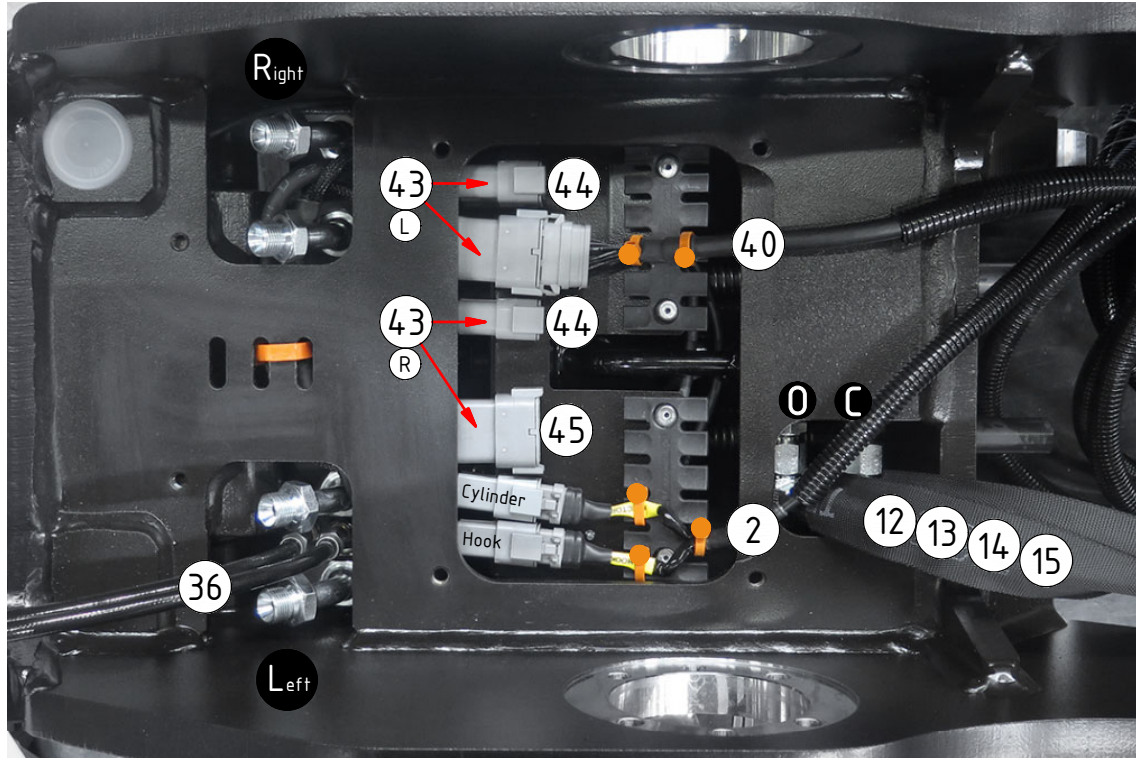

Option 5 hyd:

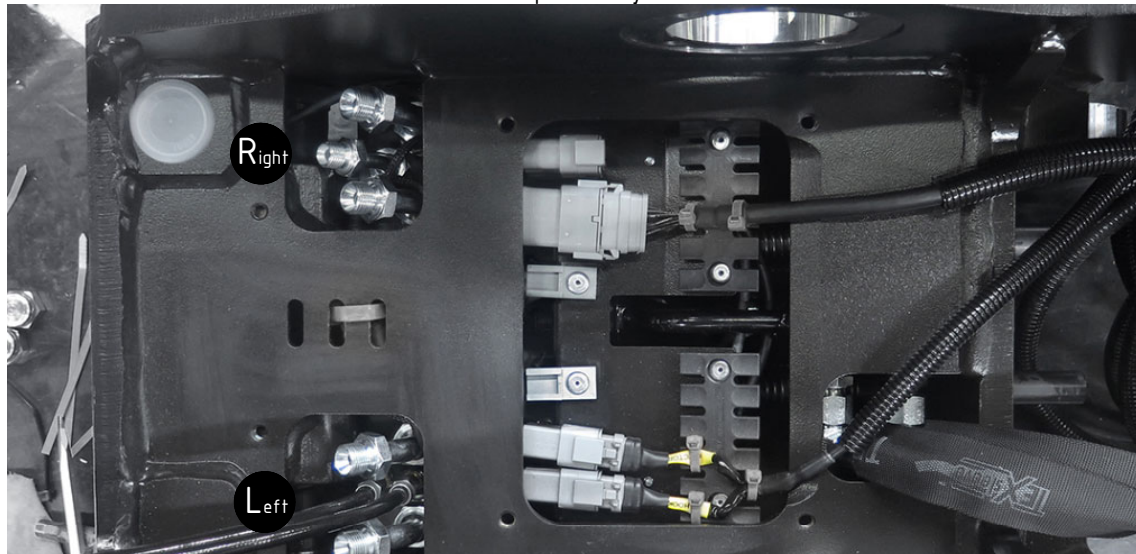

POS	DESCRIPTION	PART	QTY	COMMENTS
2	Cable QS - QLM - Quick hitch	842149	1	Attach to QS sensors
9	Rubber steel clamp ø10	6000003	2	
12	Hose Lock	741505	2	
13	Hose Lock - Liebherr	7000560	2	
14	Hose Lock - Lännen	7000561	2	
15	Hose Lock - Huddig	7001484	2	
36	Hose kit - lubricant ECO W	7000514	1	(POS.37-39 incl.)
40	Machine cable ECO45/50 W DC2	1048527	1	Attach to Left 12P
43	Power plug ECO W Hitch (12P, 6P)	1042244	1	Cable gland torque: 6Nm
44	Plug for 6P	8000620	1	QTY depends on config.
45	Plug for 12P	8002058	1	QTY depends on config.
● Use cable ties				

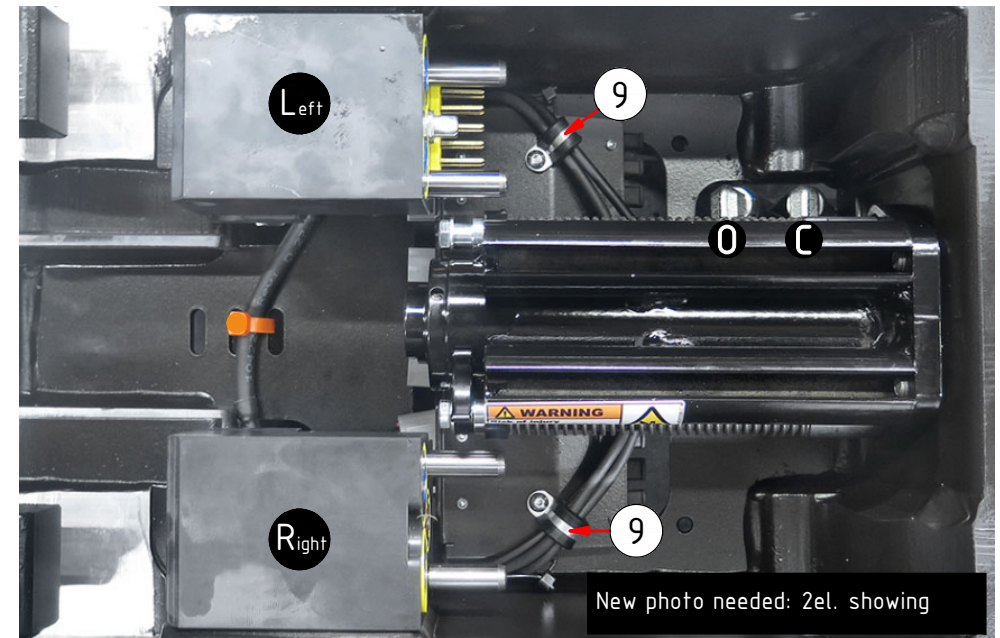

New photo needed: 2el. showing

POS in order of assembly

EC-Oil QS45 ss9

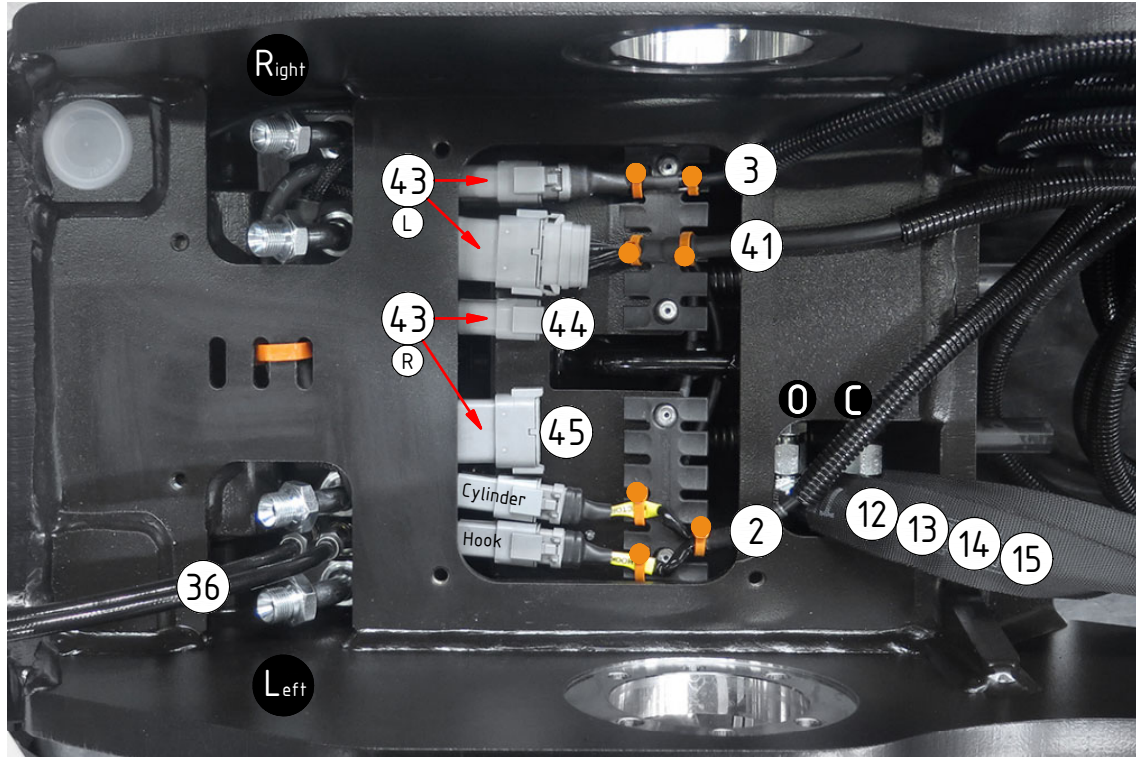

Option ePS:

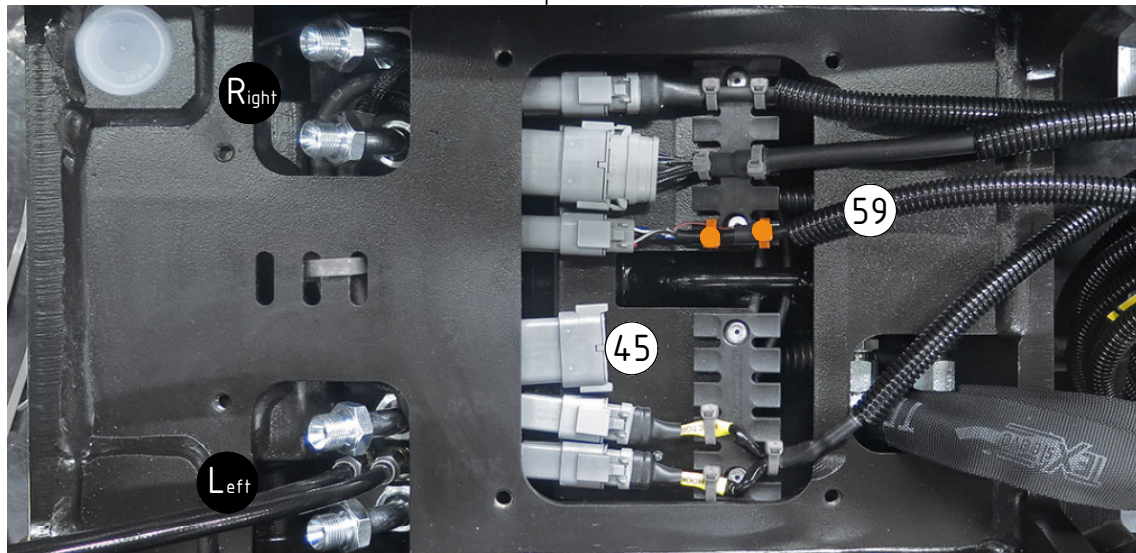

POS	DESCRIPTION	PART	QTY	COMMENTS
2	Cable QS - QLM - Quick hitch	842149	1	Attach to QS sensors
3	Cable QS - QLM - Tilt rotator	842148	1	Attach to Left 6P
9	Rubber steel clamp $\varnothing 10$	6000003	2	
12	Hose Lock	741505	2	
13	Hose Lock - Liebherr	7000560	2	
14	Hose Lock - Lännen	7000561	2	
15	Hose Lock - Huddig	7001484	2	
36	Hose kit - lubricant ECO W	7000514	1	(POS.37-39 incl.)
41	Machinecable ECO W ss9-2 (1x 12P)	1036844	1	Attach to Left 12P
43	Power plug ECO W Hitch (12P, 6P)	1042244	1	Cable gland torque: 6Nm
44	Plug for 6P	8000620	1	QTY depends on config.
45	Plug for 12P	8002058	1	QTY depends on config.
59	Cable ePS ECO W ss9,ss10(SVAB)	1042246	1	Attach to Right 6P
● Use cable ties				

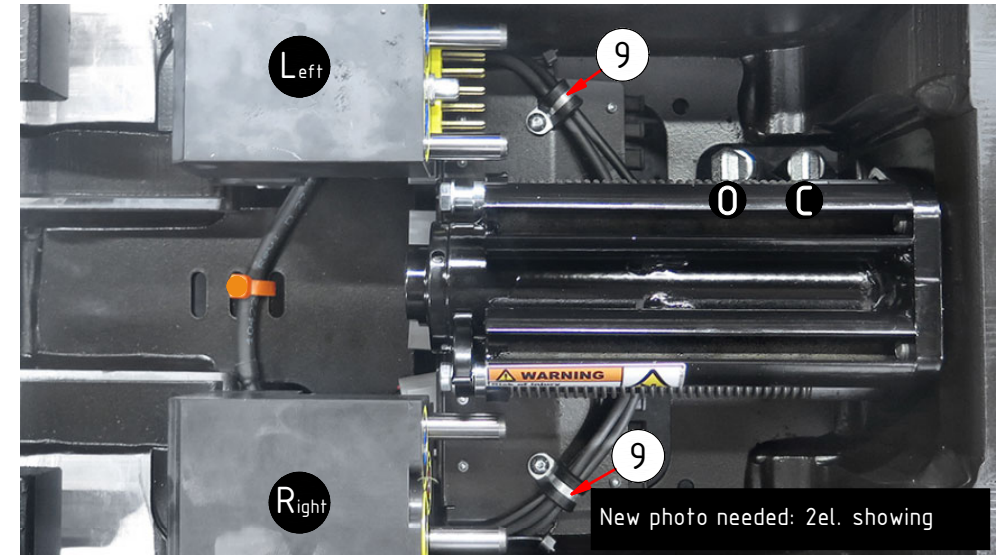

New photo needed: 2el. showing

POS in order of assembly

EC-Oil QS45
ss10 (SVAB)

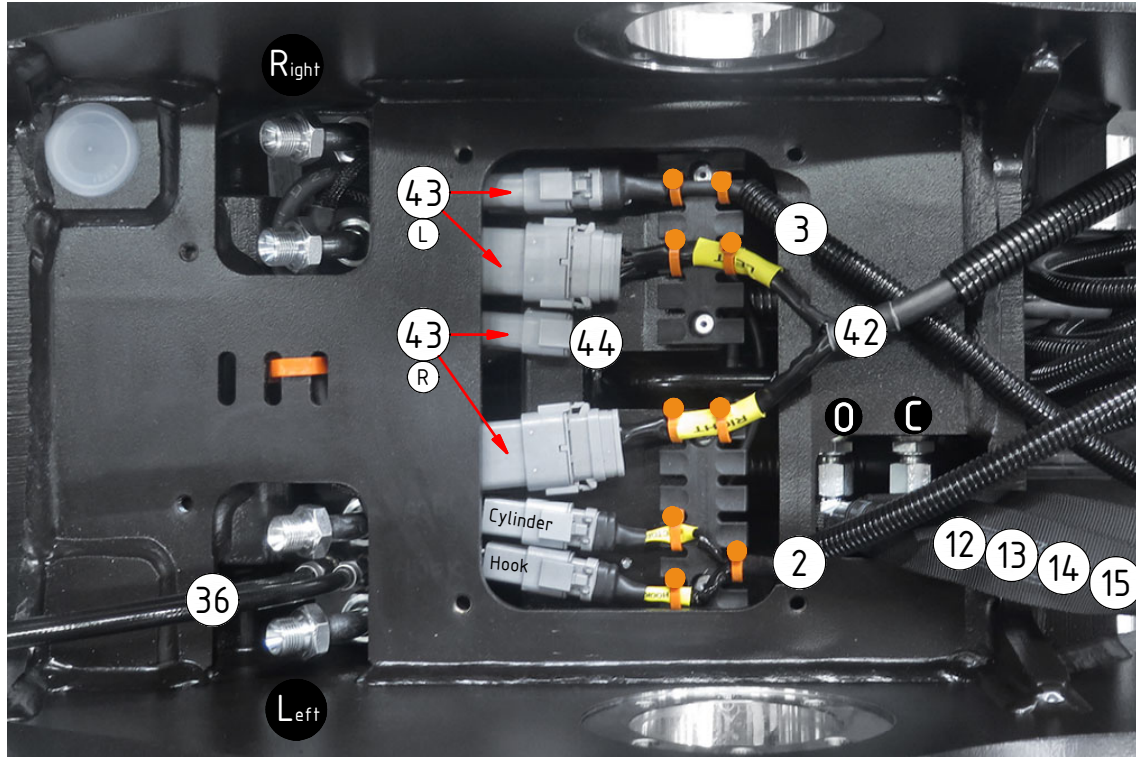

Option ePS:

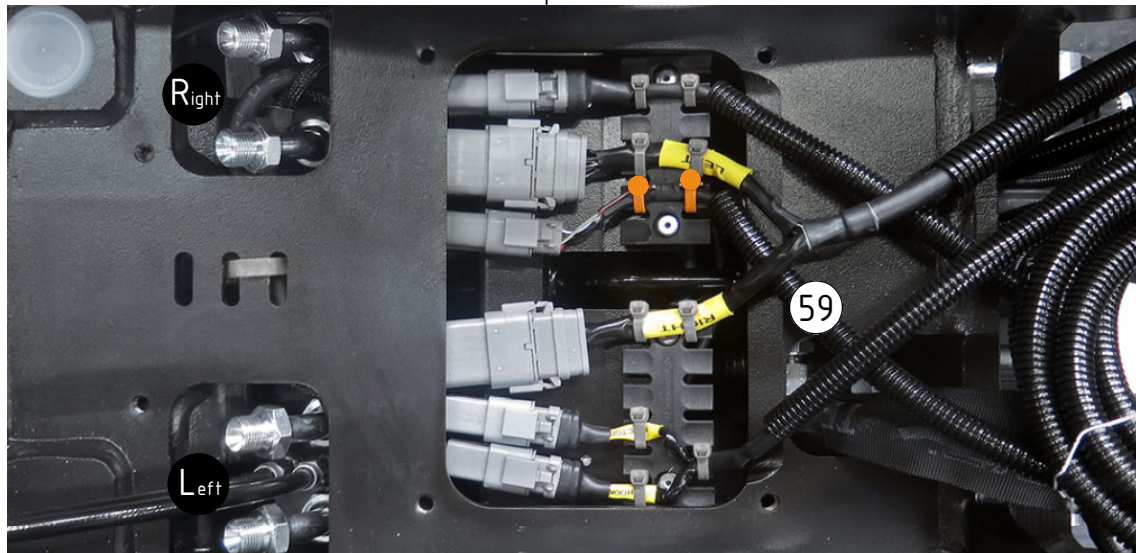

POS	DESCRIPTION	PART	QTY	COMMENTS
2	Cable QS - QLM - Quick hitch	842149	1	Attach to QS sensors
3	Cable QS - QLM - Tilt rotator	842148	1	Attach to Left 6P
9	Rubber steel clamp $\varnothing 10$	6000003	2	
12	Hose Lock	741505	2	
13	Hose Lock - Liebherr	7000560	2	
14	Hose Lock - Lännen	7000561	2	
15	Hose Lock - Huddig	7001484	2	
36	Hose kit - lubricant ECO W	7000514	1	(POS.37-39 incl.)
42	Machinecable ECO W SVAB (2x 12P)	8002008	1	Attach to both 12P
43	Power plug ECO W Hitch (12P, 6P)	1042244	1	Cable gland torque: 6Nm
44	Plug for 6P	8000620	1	QTY depends on config.
59	Cable ePS ECO W ss9,ss10(SVAB)	1042246	1	Attach to Right 6P
● Use cable ties				

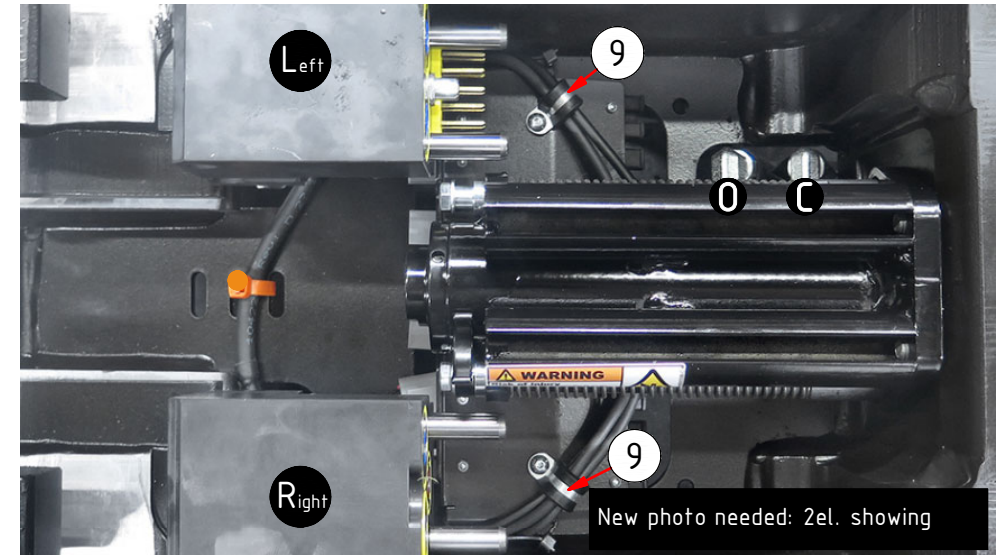

POS in order of assembly

EC-Oil QS50
DC3

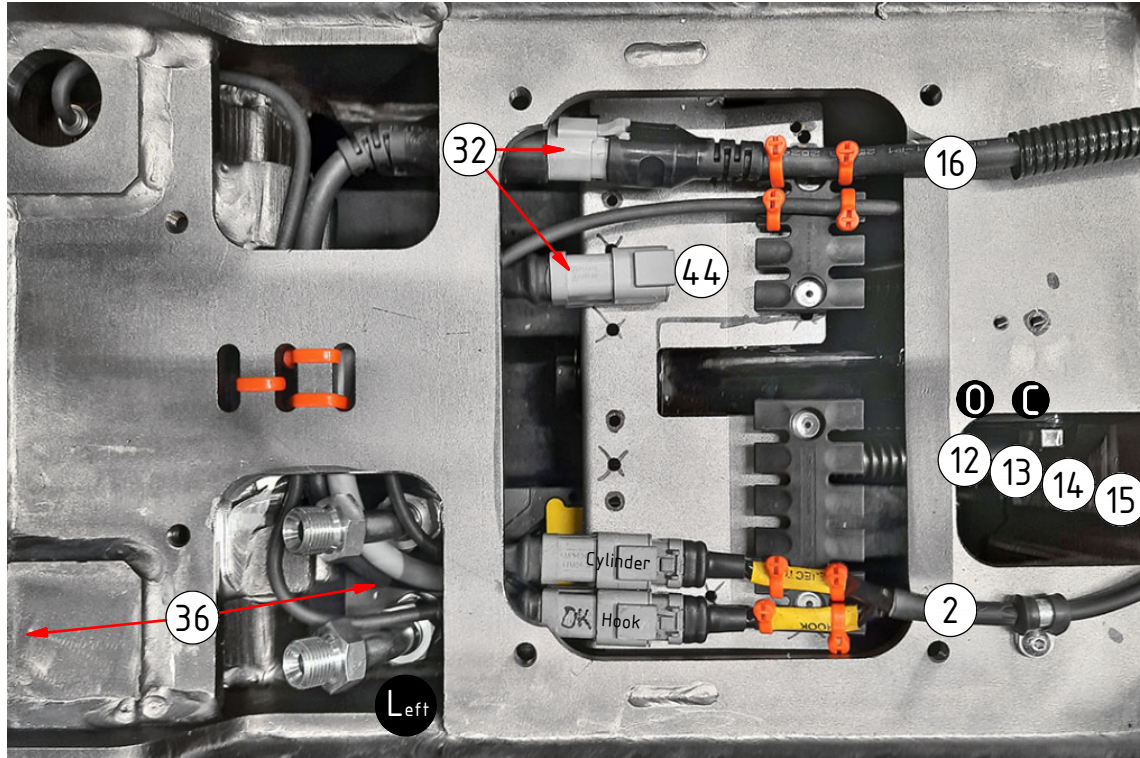

POS	DESCRIPTION	PART	QTY	COMMENTS
2	Cable QS - QLM - Quick hitch	842149	1	Attach to QS sensors
12	Hose Lock	741505	2	
13	Hose Lock - Liebherr	7000560	2	
14	Hose Lock - Lannen	7000561	2	
15	Hose Lock - Huddig	7001484	2	
16	Cable ECO W DC3 3m (4S, 4P)	8002297	1	Attach to 4P
32	Power plug ECO W Hitch (4P, 6P)	8002149	1	
36	Hose kit - lubricant ECO W	7000514	1	(POS.37-39 incl.)
44	Plug for 6P	8000620	1	QTY depends on config.
●	Use cable ties			

POS in order of assembly

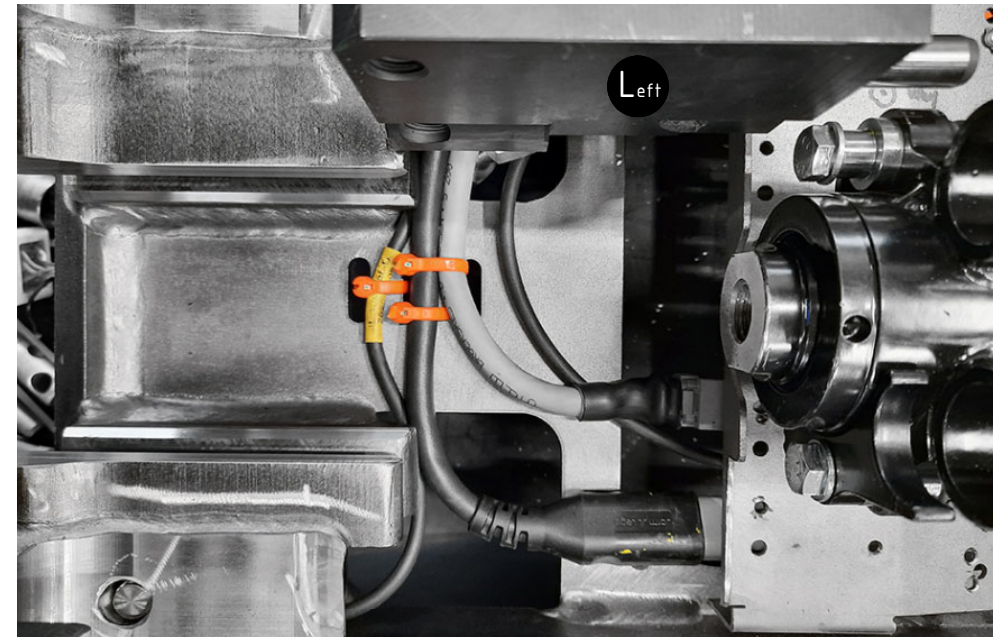

EC-Oil QS50
DC2 Std. config.

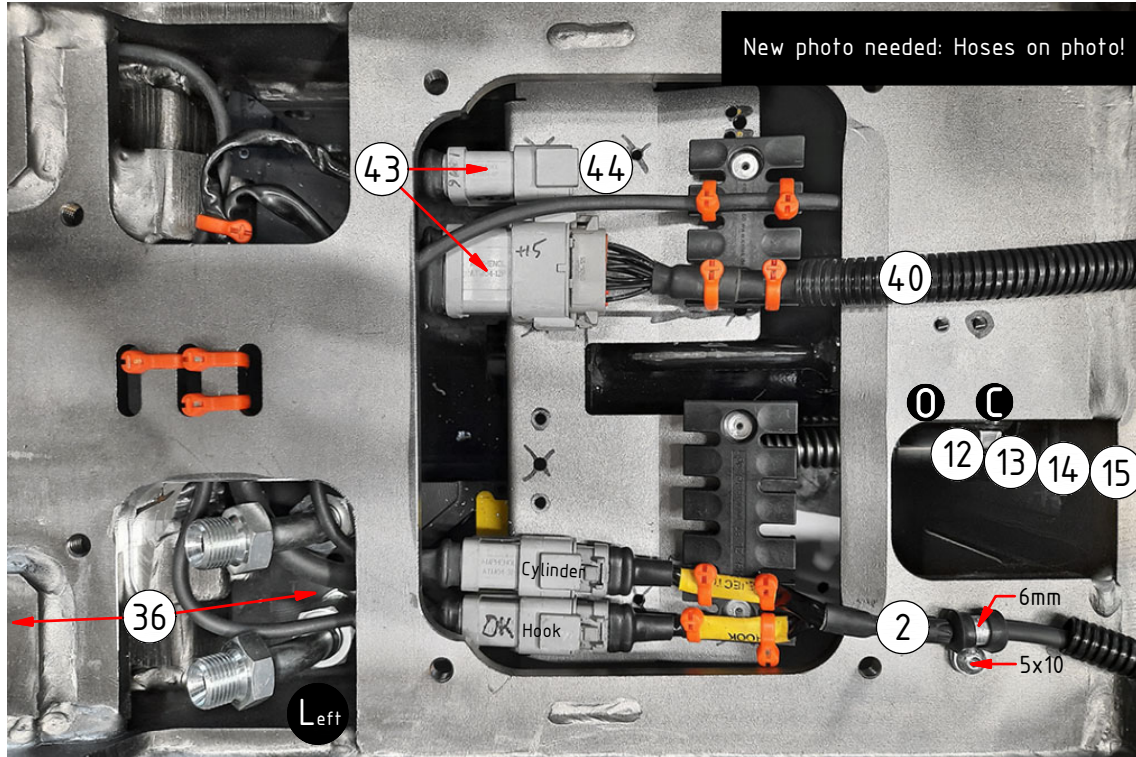

POS	DESCRIPTION	PART	QTY	COMMENTS
2	Cable QS - QLM - Quick hitch	842149	1	Attach to QS sensors
9	Rubber steel clamp \varnothing 10	6000003	2	
12	Hose Lock	741505	2	
13	Hose Lock - Liebherr	7000560	2	
14	Hose Lock - Lännen	7000561	2	
15	Hose Lock - Huddig	7001484	2	
36	Hose kit - lubricant ECO W	7000514	1	(POS.37-39 incl.)
40	Machine cable ECO45/50 W DC2	1048527	1	Attach to 12P
43	Power plug ECO W Hitch (12P, 6P)	1042244	1	Cable gland torque: 6Nm
44	Plug for 6P	8000620	1	QTY depends on config.
● Use cable ties				

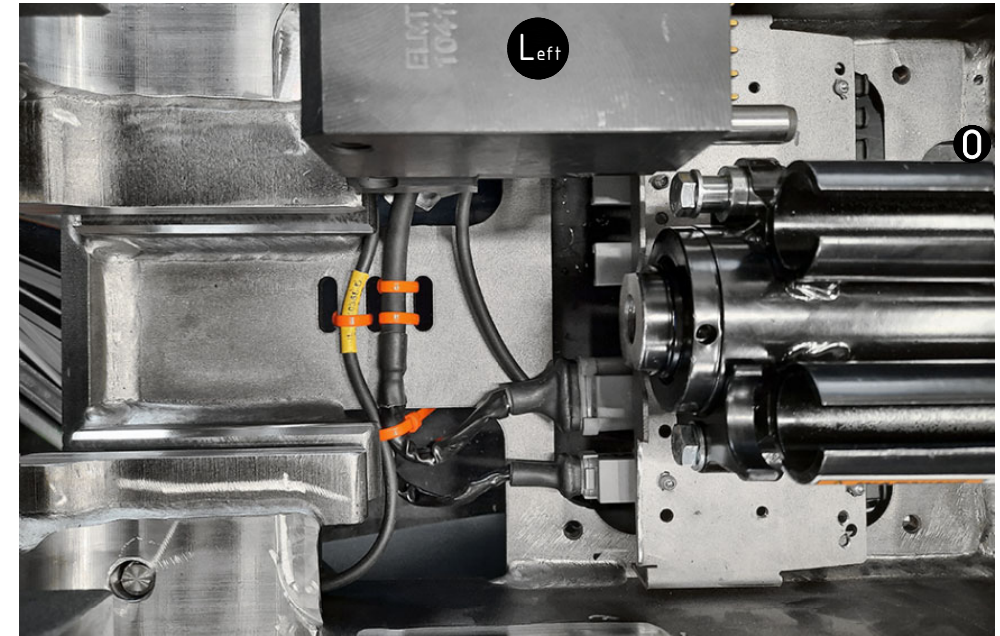

POS in order of assembly

EC-Oil QS50
DC2 Option 2bl.

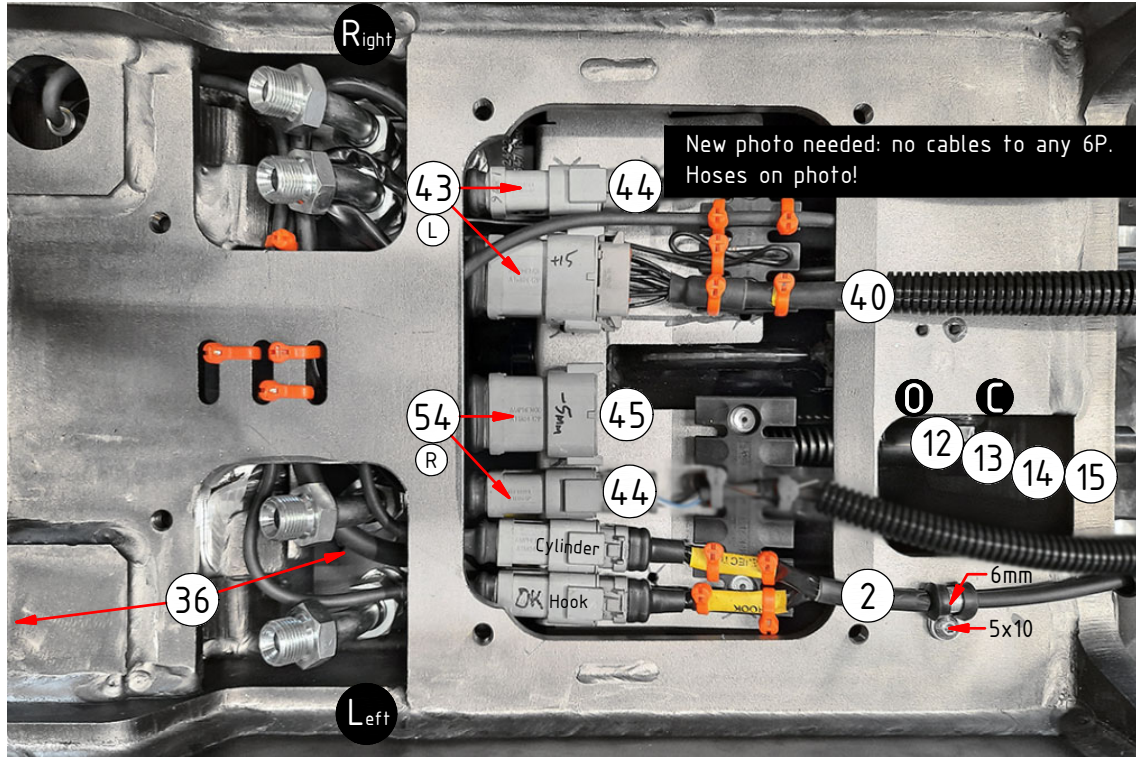

POS	DESCRIPTION	PART	QTY	COMMENTS
2	Cable QS - QLM - Quick hitch	842149	1	Attach to QS sensors
9	Rubber steel clamp $\varnothing 10$	6000003	2	
12	Hose Lock	741505	2	
13	Hose Lock - Liebherr	7000560	2	
14	Hose Lock - Lännen	7000561	2	
15	Hose Lock - Huddig	7001484	2	
36	Hose kit - lubricant ECO W	7000514	1	(POS.37-39 incl.)
40	Machine cable ECO45/50 W DC2	1048527	1	Attach to Left 12P
43	Power plug ECO W Hitch (12P, 6P)	1042244	1	Cable gland torque: 6Nm
44	Plug for 6P	8000620	1	QTY depends on config.
45	Plug for 12P	8002058	1	QTY depends on config.
54	Power plug ECO50 W Hitch (QSM)	8002007	1	Cable gland torque: 6Nm
●	Use cable ties			

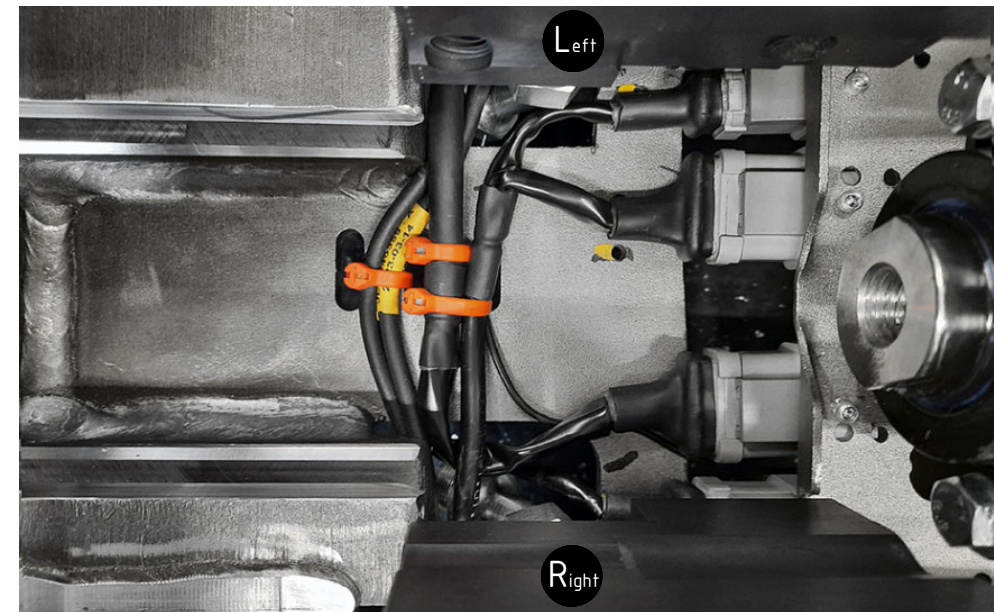

POS in order of assembly

EC-Oil QS50
ss9

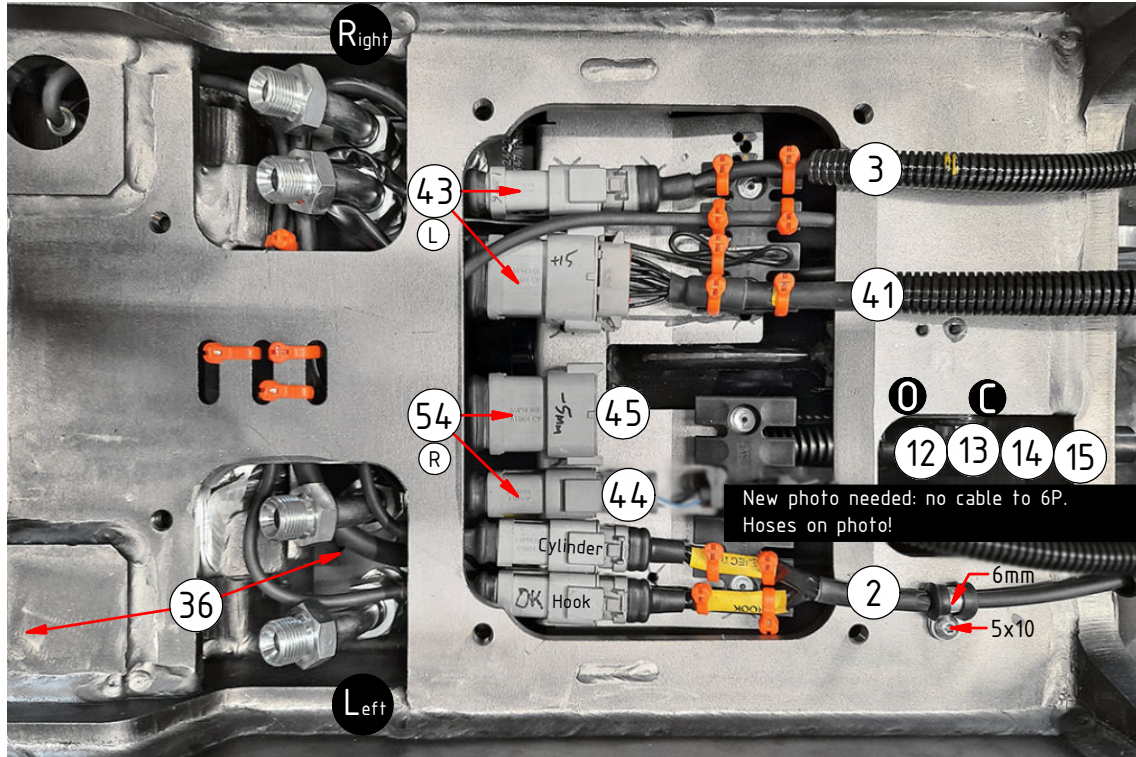

POS	DESCRIPTION	PART	QTY	COMMENTS
2	Cable QS - QLM - Quick hitch	842149	1	Attach to QS sensors
3	Cable QS - QLM - Tilt rotator	842148	1	Attach to Left 6P
9	Rubber steel clamp $\varnothing 10$	6000003	2	
12	Hose Lock	741505	2	
13	Hose Lock - Liebherr	7000560	2	
14	Hose Lock - Lännen	7000561	2	
15	Hose Lock - Huddig	7001484	2	
36	Hose kit - lubricant ECO W	7000514	1	(POS.37-39 incl.)
41	Machinecable ECO W ss9-2 (1x 12P)	1036844	1	Attach to Left 12P
43	Power plug ECO W Hitch (12P, 6P)	1042244	1	Cable gland torque: 6Nm
44	Plug for 6P	8000620	1	QTY depends on config.
45	Plug for 12P	8002058	1	QTY depends on config.
54	Power plug ECO50 W Hitch (QSM)	8002007	1	Cable gland torque: 6Nm
59	Cable ePS ECO W ss9,ss10(SVAB)	1042246	1	Attach to Right 6P
● Use cable ties				

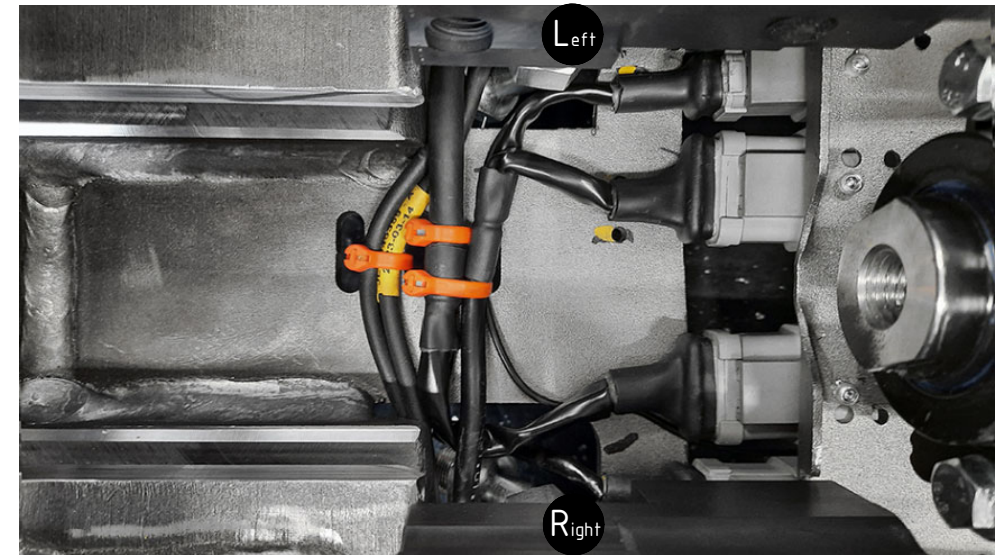

Option ePS:

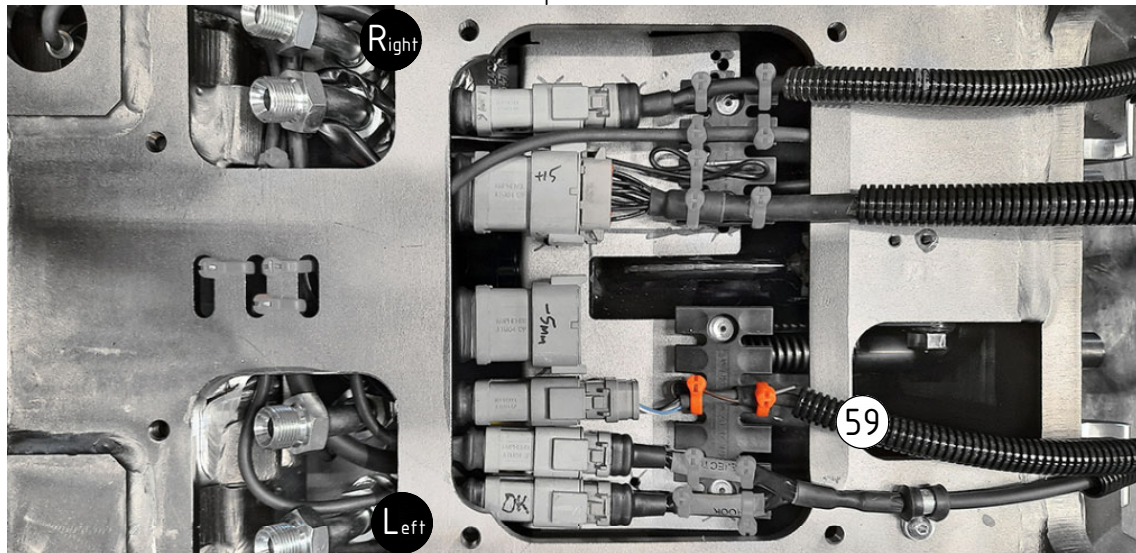

POS in order of assembly

EC-Oil QS50 ss10 (SVAB)

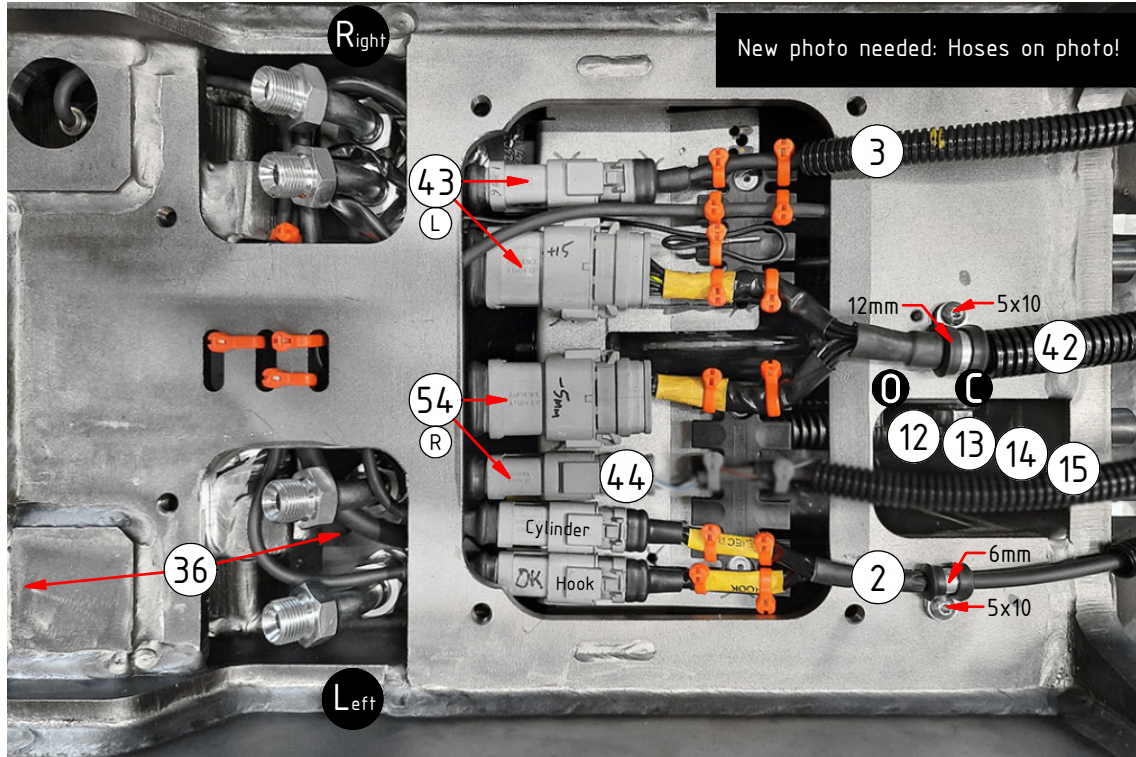

POS	DESCRIPTION	PART	QTY	COMMENTS
2	Cable QS - QLM - Quick hitch	842149	1	Attach to QS sensors
3	Cable QS - QLM - Tilt rotator	842148	1	Attach to Left 6P
9	Rubber steel clamp $\varnothing 10$	6000003	2	
12	Hose Lock	741505	2	
13	Hose Lock - Liebherr	7000560	2	
14	Hose Lock - Lännen	7000561	2	
15	Hose Lock - Huddig	7001484	2	
36	Hose kit - lubricant ECO W	7000514	1	(POS.37-39 incl.)
42	Machinecable ECO W SVAB (2x 12P)	8002008	1	Attach to both 12P
43	Power plug ECO W Hitch (12P, 6P)	1042244	1	Cable gland torque: 6Nm
44	Plug for 6P	8000620	1	QTY depends on config.
54	Power plug ECO50 W Hitch (QSM)	8002007	1	Cable gland torque: 6Nm
59	Cable ePS ECO W ss9,ss10(SVAB)	1042246	1	Attach to Right 6P
● Use cable ties				

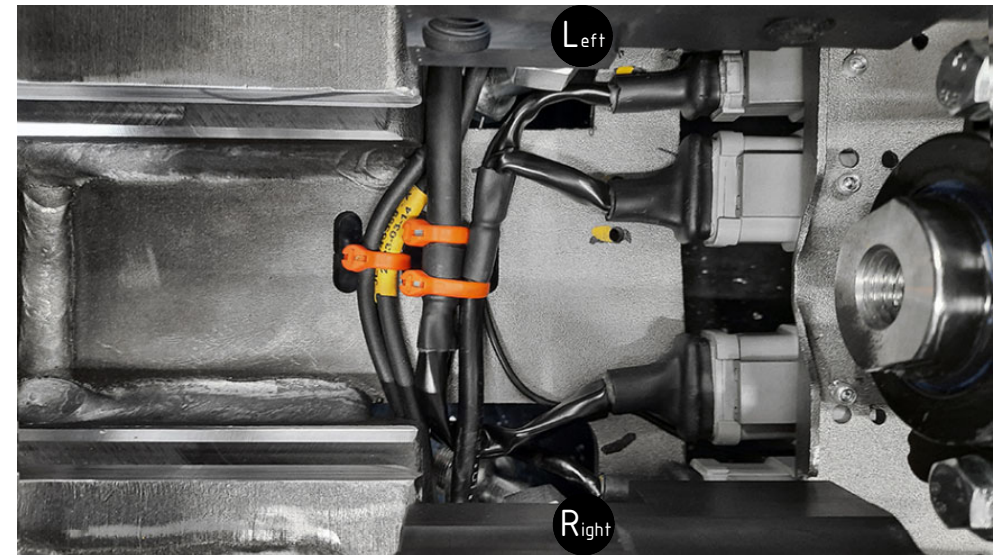

Option ePS:

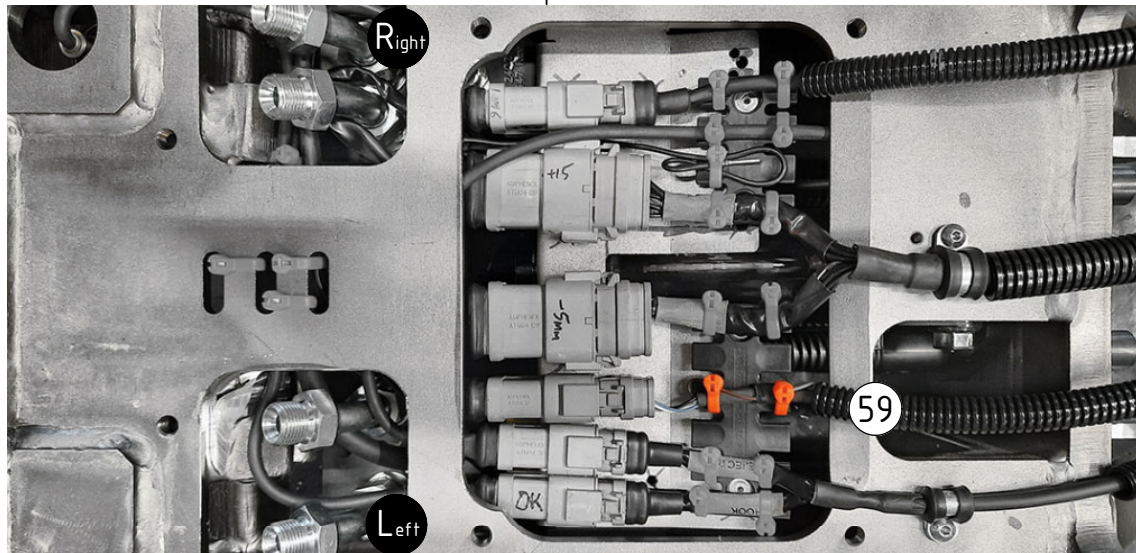

POS in order of assembly

RELATED SPARE PARTS

Until 2024-06:

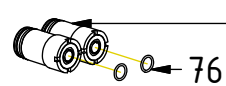
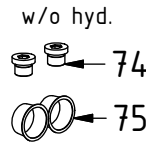
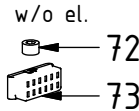
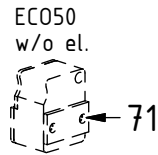
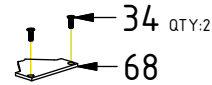

1025586
O-rings between versions are not compatible

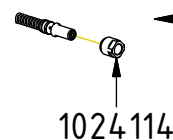

1042362
Replaced by POS.21 from 2019-01. On ECO blocks previous rev E: remove o-ring on nut

QS45: Replaced from 2019-10
QS50: Replaced from 2026-04

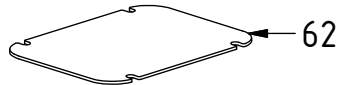

POS	DESCRIPTION	PART	QTY	COMMENTS
18	Coupling ECO W 3/8" V3	1053029	2	Torque: 60Nm. (POS.19 incl.)
19	Flat sealing for ECO W 3/8" V3	1052976	2	
21	Lubrication kit ECO W	1050794	1	(POS.22-28 incl.)
33	Coverplate block ECO45 W Hitch	1074695	1	
34	Screw MKFT 4x12	6000121	4	
40	Machine cable ECO45/50 W DC2	1048527	1	Attach to Left 12P
42	Machinecable ECO W SVAB (2x 12P)	8002008	1	Attach to both 12P
54	Power plug ECO50 W Hitch (QSM)	8002007	1	Cable gland torque: 6Nm
61	Cover QS45/50 V3	1053624	1	
62	Cover QS45/50	1025581	1	Replaced by POS.61
68	Coverplate w/o slot ECO45 W	1041098	1	Used for block w/o cable slot
69	Machinecable ECO W SVAB (2x 12P)	1029500	1	Replaced by POS.42 from 2023-06
70	Power plug ECO50 W Hitch (QS/QSD)	1045167	1	Replaced by POS.54 from 2023-06 Not compatible with QSM
71	Transport Protection ECO50 w/o el.	1049168	1	Part of make up
72	Pipe plug DIN 906 M16x1,5	711529	1	
73	Plug ECO W - Hitch	1041814	1	
74	Plug 70125-06 (3/8")	711504	2	
75	Protection plug ECO45/50 hydraulic	7000153	2	
76	O-ring 12,42x1,78 PU - ECO45 3/8"	712417	2	Used until 2020-03 Separate seal kit: 7000045
77	Cable ECO Tiltangle sensor DC2 ePS	8002477	1	Attach to 6P (DC2 ePS1) NB! Only compatible with 8002459
78	Cable ECO W Tiltanglesensor ss9-2	1047113	1	Attach to Right 12P
79	Cable ECO W Tiltanglesensor SVAB	1047111	1	L.Bl: WH>11. R.Bl: BR>1, BL>2, GR>11
80	Machine cable ECO45/50 W DC2 two connectors	1042247	1	Replaced by POS.40 from 2018-08 Attach to 6P and 12P
81	Machine cable ECO45/50 W MACS	1043276	1	Attach to 12P

