

COVERSHEET

Planned document changes:

Briefly:

2026-05-22. Add to POS.28-29: Torque 40Nm.

Document changes:

Date:	Change:	Rev. after change:
2025-03-25	Hoses for ss9/ss0 updated.	C
2025-02-26	Photos added.	B
2024-10-24	New document.	A
2024-04-24	Pre-series draft.	-

Readers note:

Indicates instruction.



Represents Hose.

Dashed lines for overview, mounts
on other pages/assemblies.

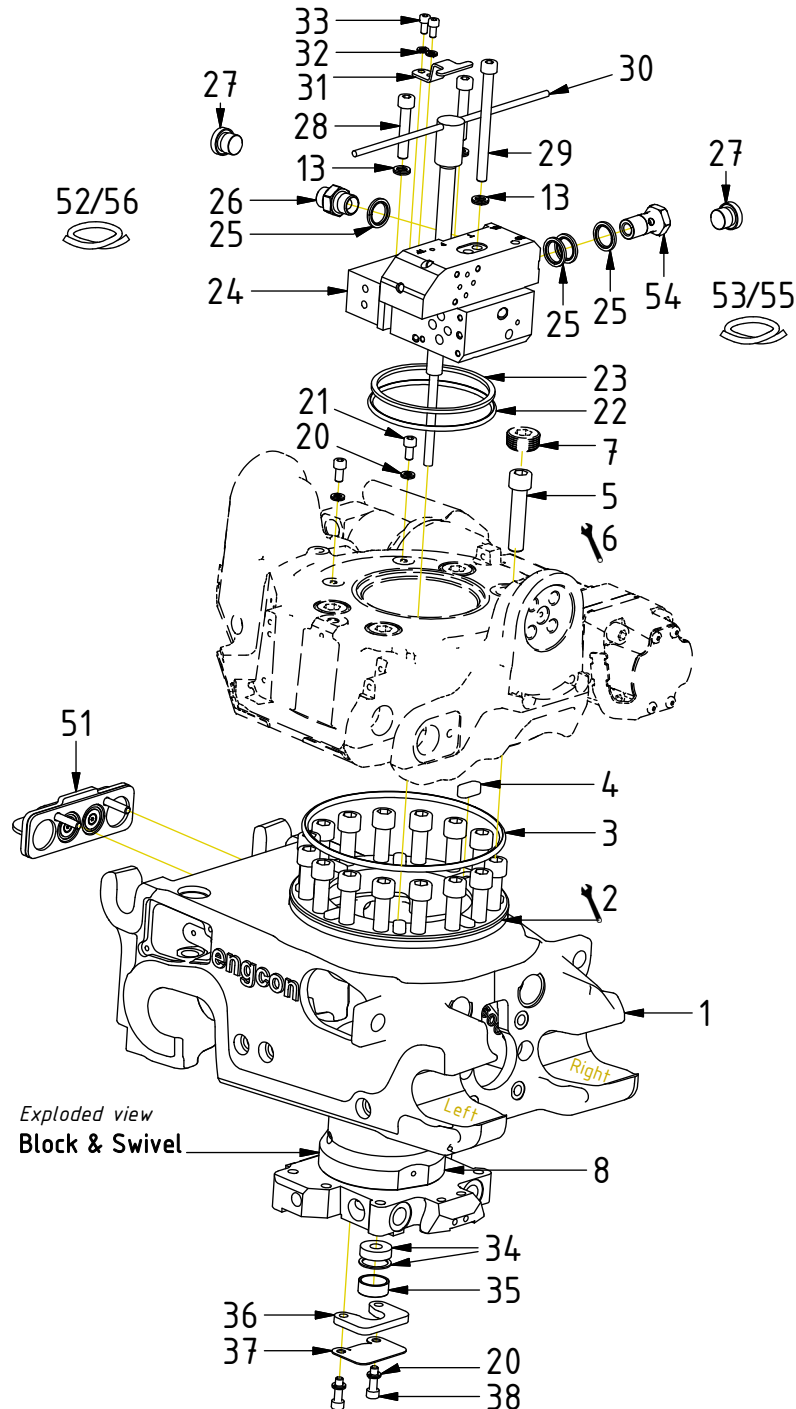

POS	DESCRIPTION	PART	QTY	COMMENTS
1	Quick hitch QSM40 EC204B	1069601	1	
2	Grease the ring			
3	O-ring 155x5,0	7001935	1	
4	Feather key 10x8x22	6000416	8	
5	Screw MC6S M12x55 12.9 ZFSHL	6000155	16	Torque: 136Nm
6	Torque tighten rotator frame to hitch. Rotate to access all holes			
7	Pipe plug DIN 906 M22x1,5	7000457	4	Part of rotator frame
8	Connect. block & swivel QSM Compl.	1077508	1	
9	O-ring 5,28x1,78	7001568	2	
10	O-ring 7,66x1,78	7001939	2	
11	O-ring 12,42x1,78	710973	2	
13	Washer NL 8mm	611040	7	QTY: 13 without EC-Oil
20	Washer NL 6mm	611039	4	
21	Screw MC6S M6x12 12.9 ZFSHL	6000352	2	
22	O-ring 96x4,0	7001941	1	
23	Ring o-ring protection 91x100/3	1075886	1	
24	Valve block EC204B	1078622	1	Part of control system assy.
25	Washer GBR06 3/8	710703	8	QTY depends on config. (4-8)
26	Adapter 136-06-06 (3/8")	710106	1	For DC2
27	Plug 70125-06 (3/8")	711504	2	For ss9, ss0
28	Screw MC6S M8x45 12.9	610438	2	
29	Screw MC6S M8x95 12.9	610446	1	
30	Slip ring EC204B	8002198	1	Mount with marine silicone
31	Cover plate slip ring	1077615	1	
32	Washer NL 5mm	611038	2	
33	Screw MC6S M5x10 12.9	610594	2	
34	Rubber bushing	1046691	1	Use the outer ring. Washer down
35	Ring slip ring QSM	1046692	1	
36	Plate cable steering QSM	1066142	1	
37	Plate Steering cable Slip ring	1066144	1	
38	Screw MC6S M6x20 8,8 FZB	610310	2	
51	Cover plate QSM40 magnet	1064311	1	
52	Hose hydraulic motor a (DC2)	7001988	1	
53	Hose hydraulic motor b (DC2)	7001987	1	
54	Banjo bolt 4451-06 (3/8")	710272	1	For DC2
55	Hose Rotation a (ss9, ss0)	7002025	1	
56	Hose Rotation b (ss9, ss0)	7002026	1	

Between swivel & valve block:

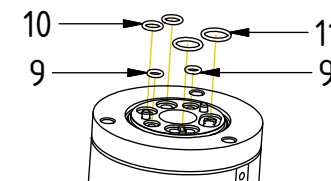

POS in order of assembly

POS	DESCRIPTION	PART	QTY	COMMENTS
12	Spacer QSM40	1063811	4	
13	Washer NL 8mm	611040	7	QTY: 13 without EC-Oil
14	Screw MC6S M8x50 12.9	610439	2	Torque: 40Nm
15	Screw MC6S M8x35 12.9	610314	2	Torque: 40Nm
16	O-ring 10,82x1,78	7001171	2	
17	Cover plate QSM40	1063797	2	
18	Screw MC6S M8x30 12.9 ZFSHL	611519	4	Torque: 40Nm
19	Screw MC6S M8x55 12.9	610588	2	Torque: 40Nm

POS in order of assembly

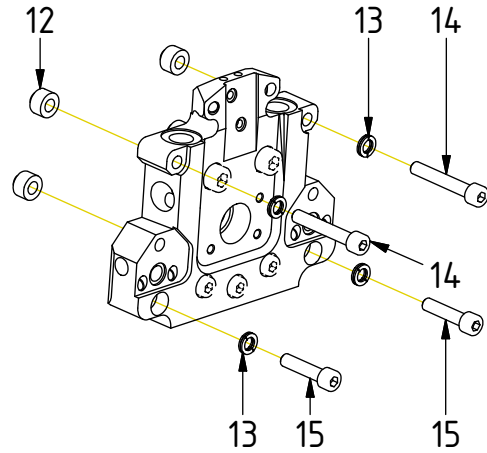

Without EC-Oil

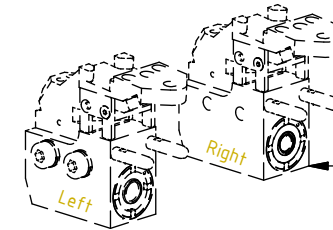
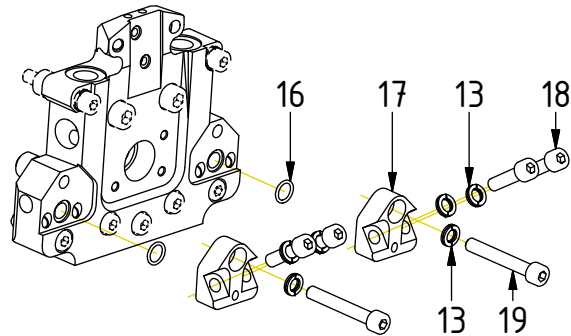

Exploded view
EC-Oil components

POS	DESCRIPTION	PART	QTY	COMMENTS
25	Washer GBR06 3/8	710703	8	QTY depends on config. (4-8)
39	Adapter extension 3/8" QSM40	1058386	2	
40	Quick coupling 3/8"	790113	2	
41	Dust protection 3/8"	790120	2	
42	Washer GBR08 1/2	710704	2	
43	Adapter pipe 1/2"	1065228	2	
44	Quick coupling 1/2"	790115	2	
45	Dust Protection 1/2"	790121	2	
46	Washer GBR04 1/4	710702	4	
47	Adapter extension QSM40	1056533	4	
48	O-ring 16,1x1,6	7001572	4	
49	Coupling ECO QSM 1/4" female	1063731	4	Loxreal 83-52. (POS.50 included)
50	Flat sealing for ECO 1/4" V3	1053936	4	

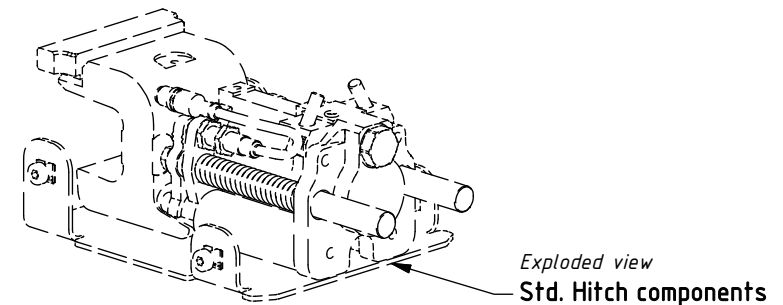
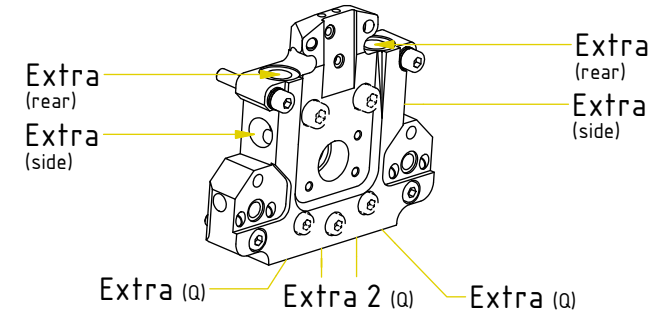
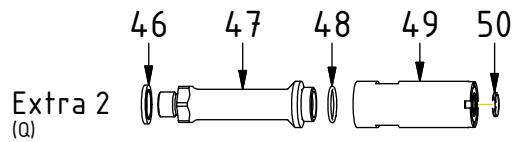
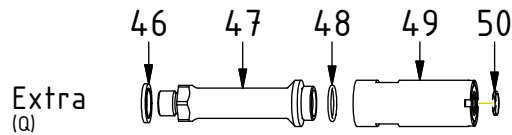
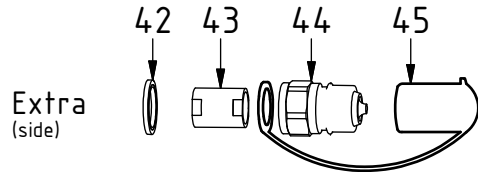
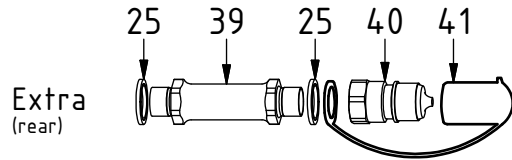

POS	DESCRIPTION	PART	QTY	COMMENTS
52	Hose hydraulic motor a (DC2)	7001988	1	
53	Hose hydraulic motor b (DC2)	7001987	1	
55	Hose Rotation a (ss9, ss0)	7002025	1	
56	Hose Rotation b (ss9, ss0)	7002026	1	

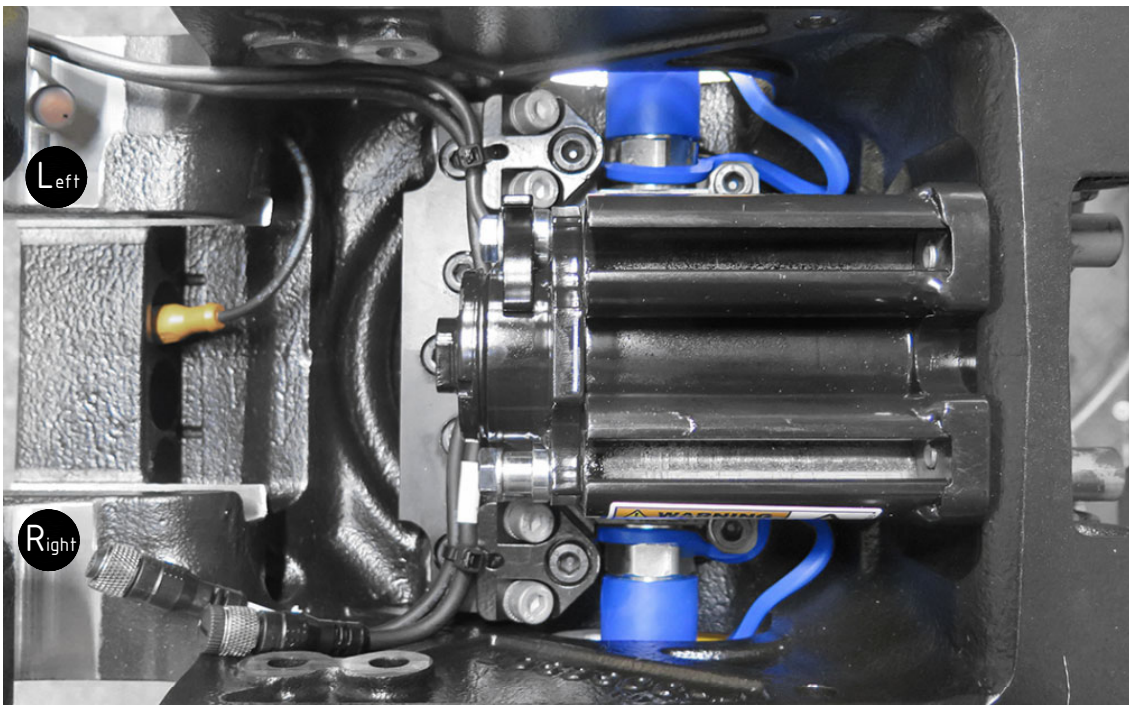
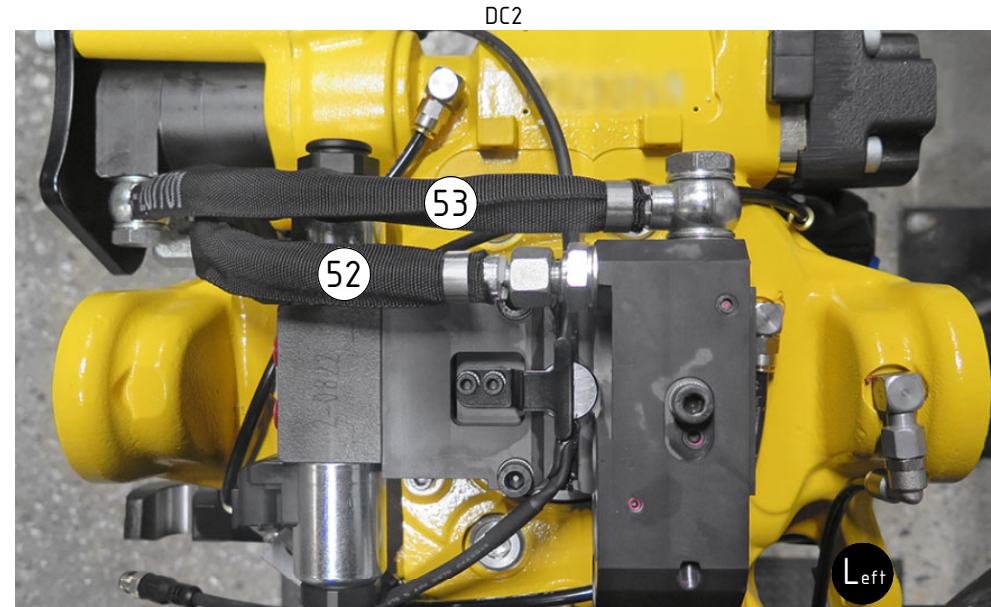
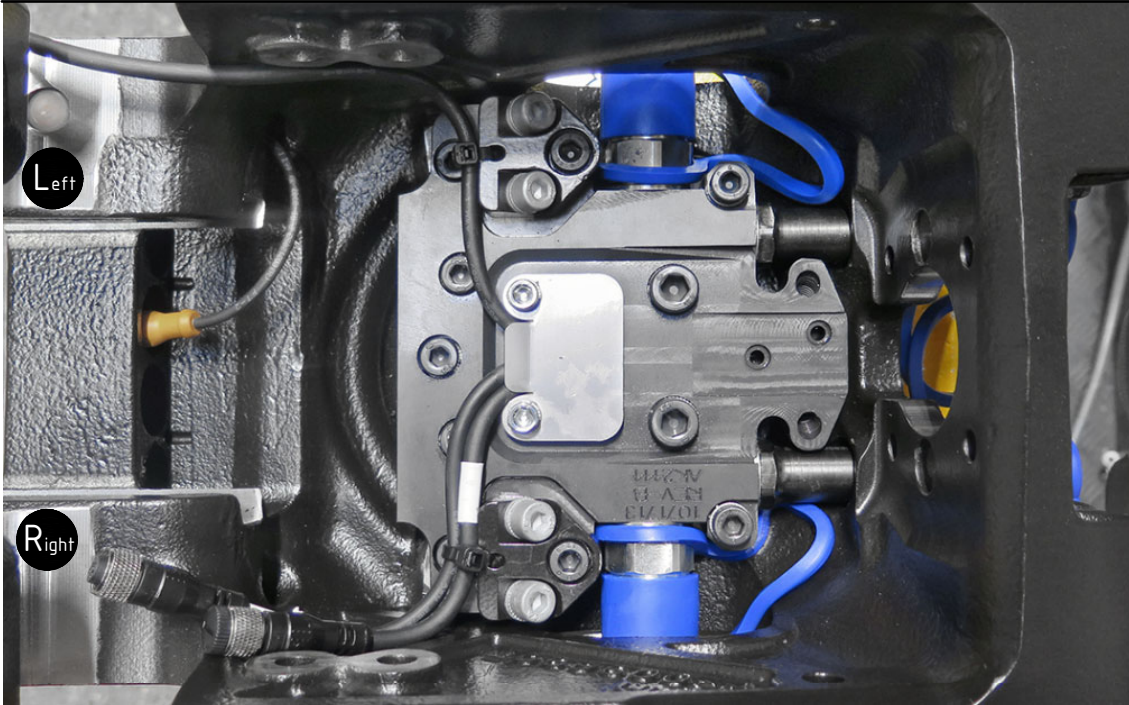

ss9, ss0

Photo needed: ss9/ss0 rotation hoses
(plugs on block, hoses left for later)