

COVERSHEET

Planned document changes:

Briefly:

2026-03-09. POS.8 will be divided to two parts: 1080808 with 1080809. (Backwards compatible).

Document changes:

<u>Date:</u>	<u>Change:</u>	<u>Rev. after change:</u>
2026-05-27	ss0 updated.	E
2023-06-21	Layout/irrelevant.	D
2022-09-07	Seal for top part clarified.	C
2022-05-31	Details for EC233S added. (EC233 with ePS2)	B
2020-10-13	Screw length corrected.	A
2019-09-04	New document.	-

Readers note:

 Indicates instruction.

 Represents Hose.

Dashed lines for overview, mounts
on other pages/assemblies.

POS	DESCRIPTION	PART	QTY	COMMENTS
1	Seal PAK-150x160x7-L	1064192	1	Face groove toward top part
2	Bushing 120/125x50 WB802	6000087	2	(Incl. in Top part)
3	Shims tilt axle	1040014	1	Use as required
4	Tilt axial washer	1039639	1	
5	Washer NL 8mm	611040	10	
6	Screw MC6S M8x40 12.9 ZFSHL	6000145	2	
7	O-ring 9,92x2,62	710968	4	
8	Tilt axle EC233	1064182	2	
9	Screw MC6S M20x110 12.9 ZFSHL	6000159	16	Torque: 649Nm
10	Magnet spacer tilt axle	1064185	1	For EC233S
11	Screw MC6S M4x14 8,8 FZB	610420	1	For EC233S
12	Cover Tilt Axle EC233 Cast	1065908	1	For EC233S
13	Protection plate tilt axle EC33	1064719	1	For EC233/EC233PS Face the groove downwards
14	Washer NL 12mm	611042	6	
15	Screw MC6S M12x20 12.9 ZFSHL	6000356	6	

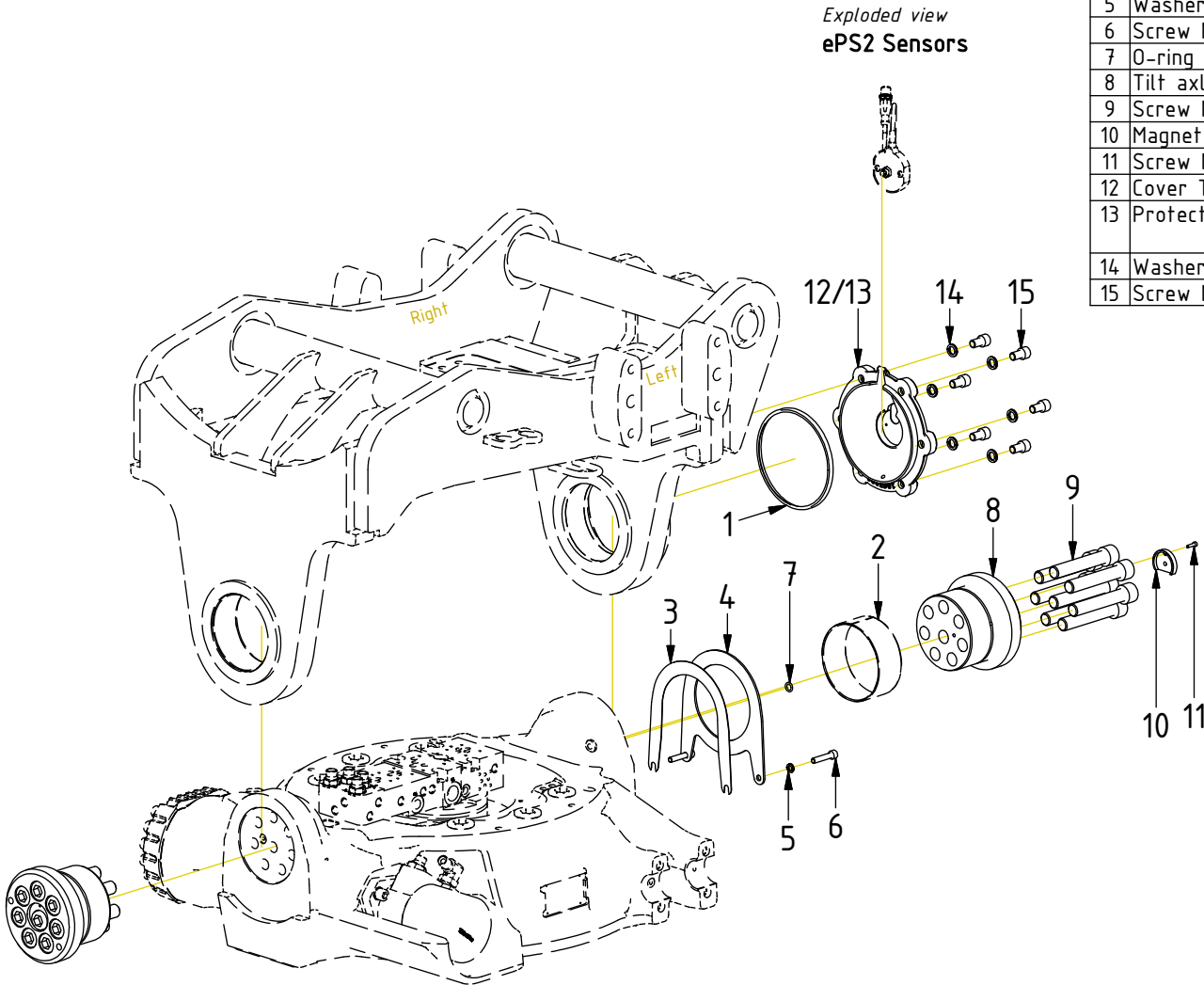

Exploded view
Tilt cylinder

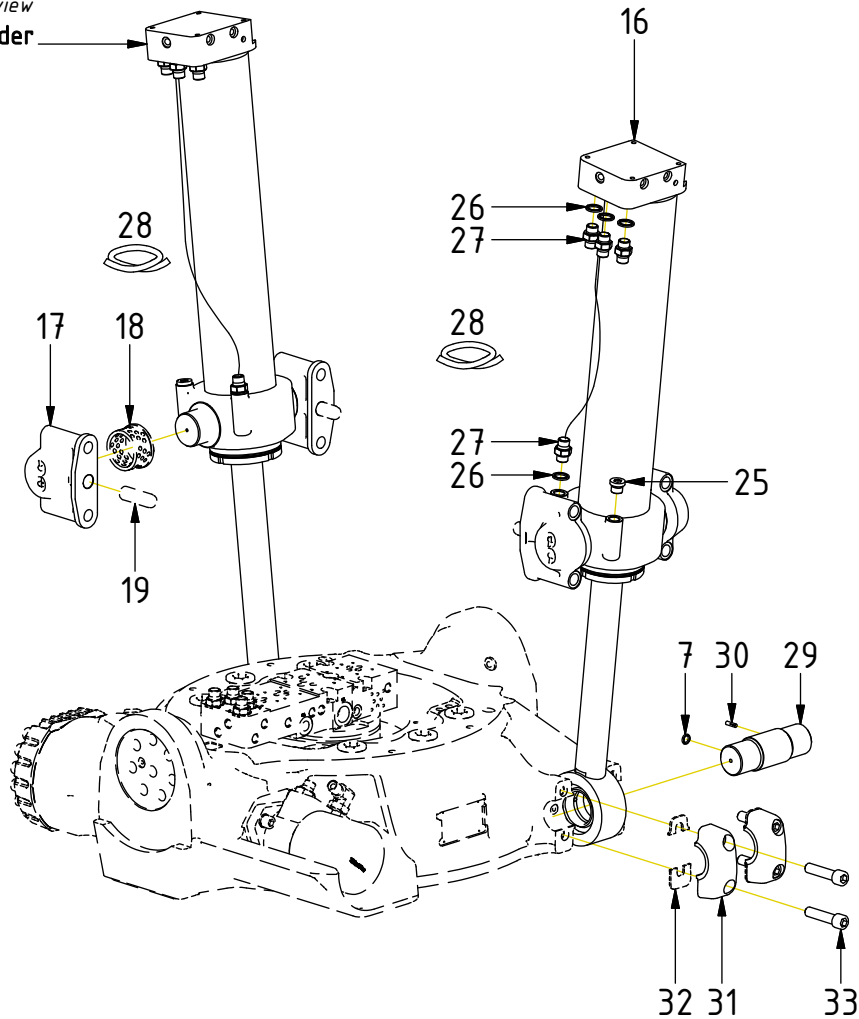

POS	DESCRIPTION	PART	QTY	COMMENTS
7	O-ring 9,92x2,62	710968	4	
16	Tilt cylinder EC233	1039112	2	
17	Yoke EC233 complete	1039018	4	(POS.18-19 incl.)
18	Bushing 50/60/65/5x35	6000086	4	
19	Cylindrical pin \varnothing 20x60	650217	4	
20	Screw MC6S M16x110 12.9 ZFSL	6000253	8	QTY: 4 for ss0, ss9 Torque: 333Nm
21	Spacer 20mm	1023777	4	
22	Hose terminal Left V2	1047137	1	
23	Hose terminal Right V2	1047138	1	
24	Screw MC6S M16x140 12.9 ZFSL	6000152	4	Torque: 333Nm
25	Plug 3/8"	711504	2	
26	Washer GBR06 3/8	710703	8	
27	Adapter 136-06-06 (3/8")	710106	8	
28	Hose Tilt Short	7000453	2	
29	Cylinder axle	1039687	2	
30	Slotted pin 5x20	640413	2	
31	Clamping half 45 Complete	1040020	4	(POS.32 incl.)
32	Rubber spacer clamping half	1040018	4	
33	Screw MC6S M14x60 12.9 ZFSL	6000160	8	Torque: 217Nm

Std fasteners

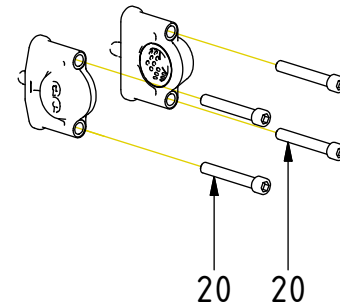

ss0, ss9

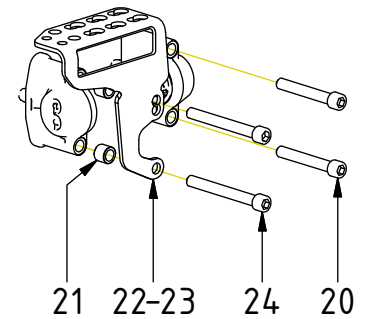

TILT

POS	DESCRIPTION	PART	QTY	COMMENTS
5	Washer NL 8mm	611040	10	
34	Hose Tilt Long	7000452	4	
35	Overcentre valve 4:1	730277	4	Torque: 60Nm
36	Hose protection Tiltcylinder	1014280	2	
37	Screw M6S M8x16 8,8 FZB	610122	8	

POS in order of assembly

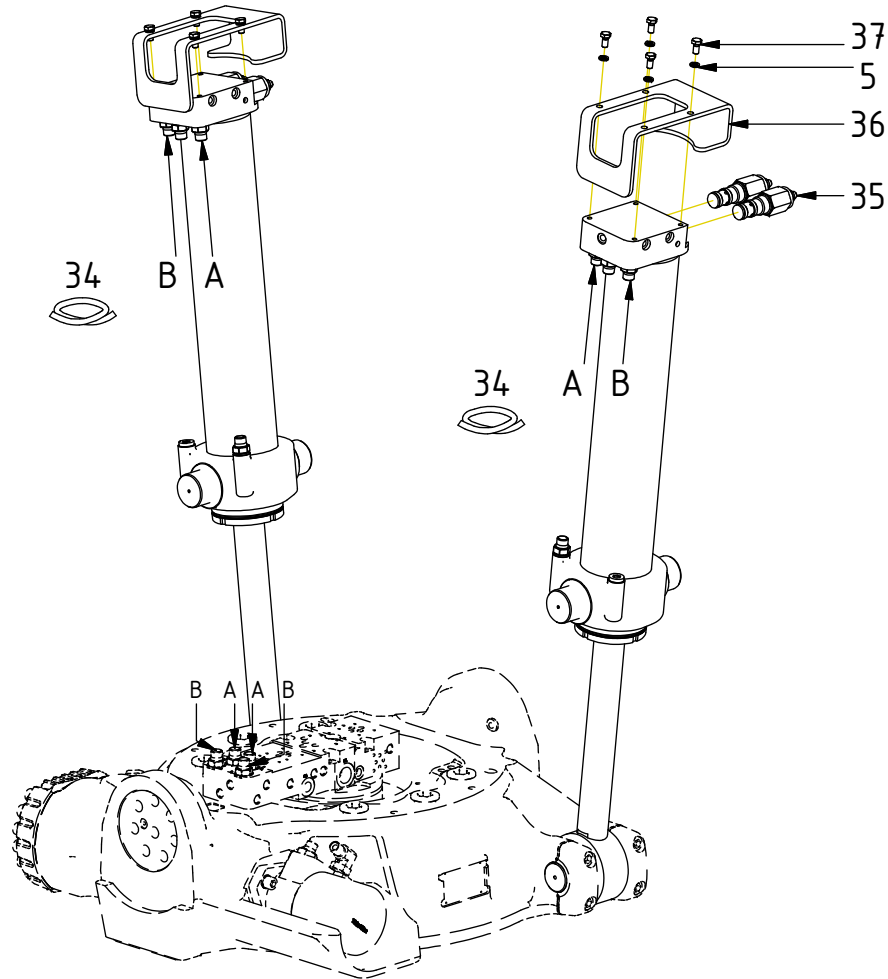

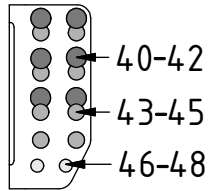

FEED

Std feed

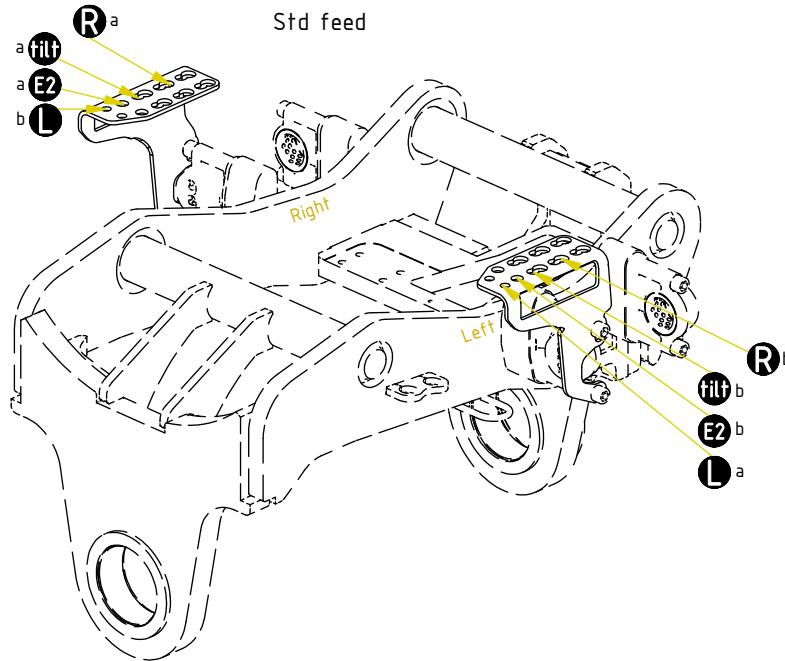

Feed Left

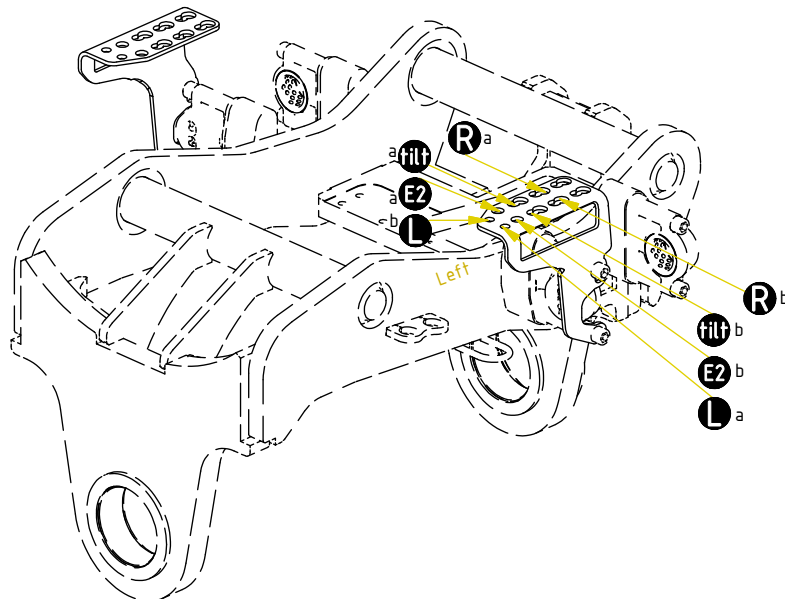

Feed Right

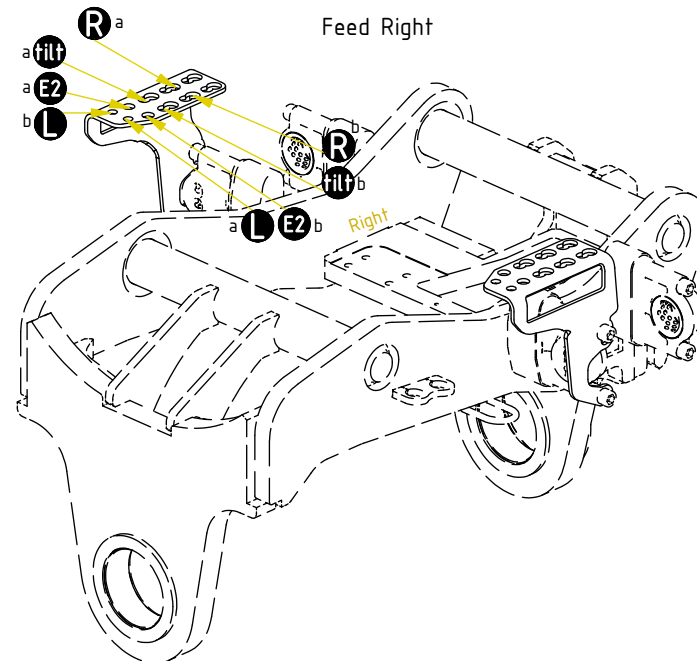

POS	DESCRIPTION	PART	QTY	COMMENTS
38	Main Feed T&P depends on top part			See "Top part"
39	For Functions & Feed Hoses			See "Control system"
40	Washer NL 20mm	611098	2	
41	Adapter 1260-08-08 (1/2")	710244	2	
42	Counternut 1270-08 (1/2")	710254	2	
43	Washer NL 16mm	611044	2	
44	Adapter 1260-06-32 (3/8")	710242	2	
45	Counternut 1270-06 (3/8")	710252	2	
46	Washer NL 1/2"	611096	2	
47	Adapter 1260-04-04 (1/4")	710240	2	
48	Counternut 1270-04 (1/4")	710250	2	

POS in order of assembly

TILT

POS	DESCRIPTION	PART	QTY	COMMENTS
28	Hose Tilt Short	7000453	2	
34	Hose Tilt Long	7000452	4	

POS in order of assembly

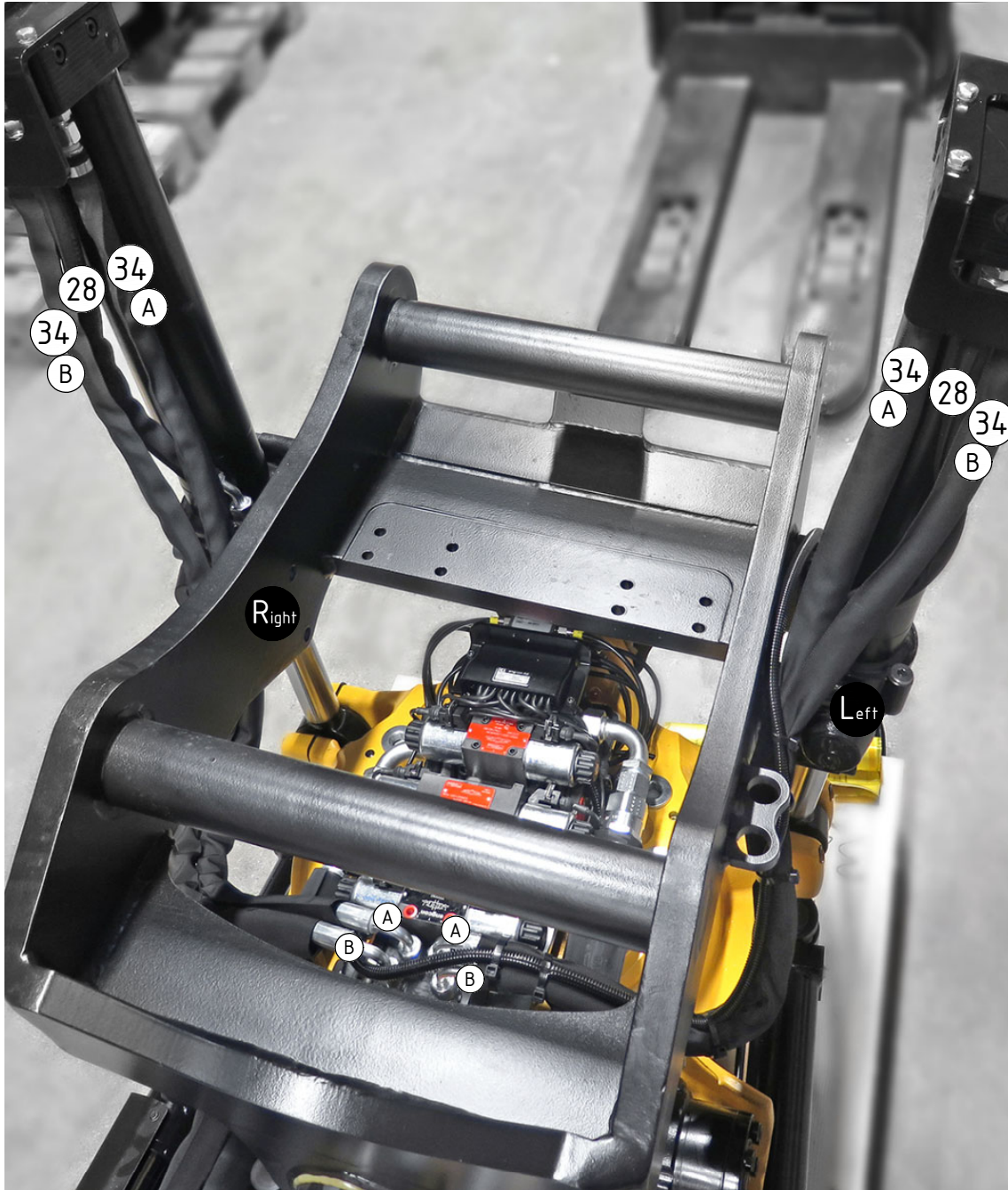

FEED

POS	DESCRIPTION	PART	QTY	COMMENTS
38	Main Feed T&P depends on top part			See "Top part"
39	For Functions & Feed Hoses			See "Control system"



Feed Left

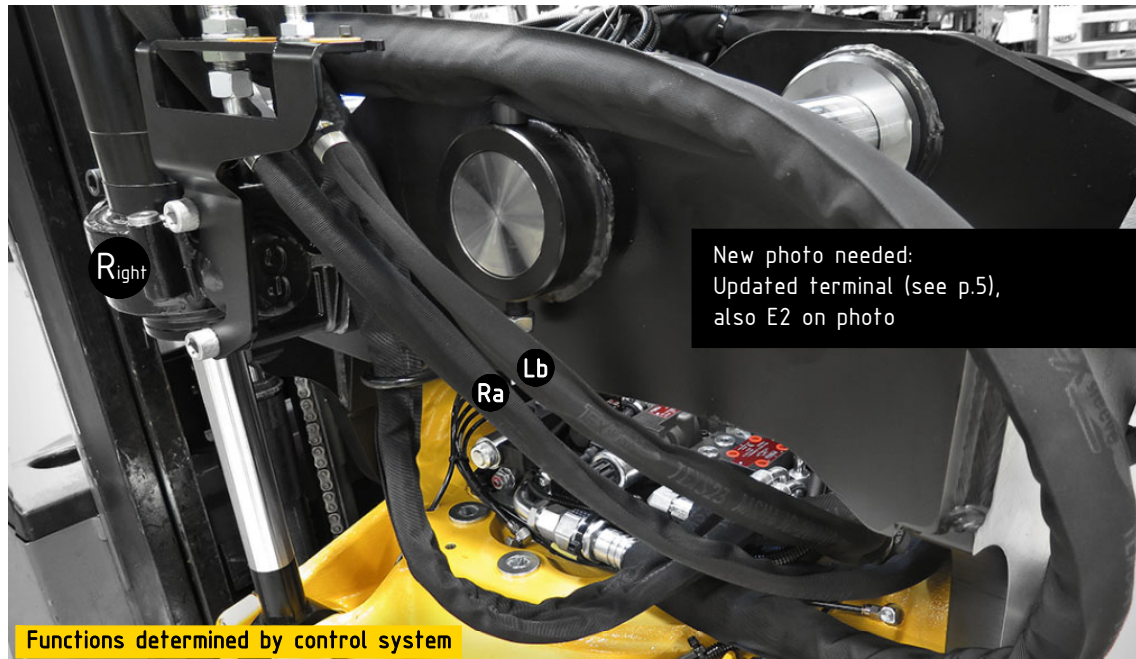
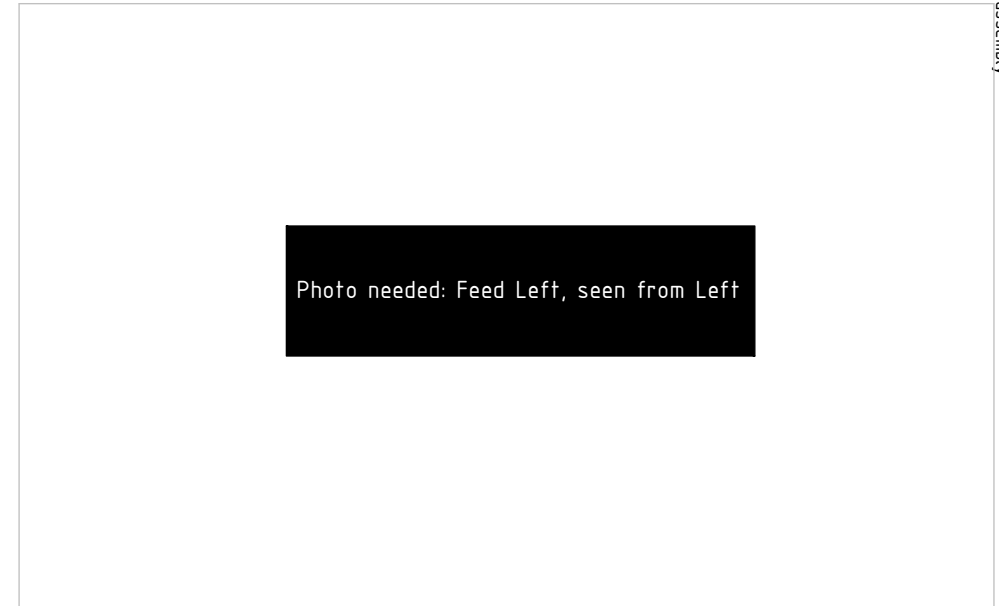

Feed Right

