

COVERSHEET

Planned document changes:

Briefly:

2026-03-09. POS.8 will be divided to two parts: 1080804 with 1080805. (Backwards compatible).

Document changes:

<u>Date:</u>	<u>Change:</u>	<u>Rev. after change:</u>
2026-05-27	ss0 updated.	F
2023-10-18	Adapters and nuts corrected. Photos updated.	E
2022-09-07	Seal for top part clarified.	D
2022-05-17	Details for EC219S added. (EC219 with ePS2 sensors).	C
2021-03-31	Option Wide added.	B
2020-10-13	Screw lengths corrected. Photos added.	A
2019-09-11	New document.	-

Readers note:

 Indicates instruction.

 Represents Hose.

Dashed lines for overview, mounts
on other pages/assemblies.

EC219 QSM - Std. Top components

POS in order of assembly

POS	DESCRIPTION	PART	QTY	COMMENTS
1	Seal PAK-110x125x7-L	1064201	1	Face groove toward top part
2	Bushing Ø85/90x35 WB802	630321	2	(Incl. in Top part)
3	Shims tilt axle	1016420	1	Use as required
4	Tilt axial washer	1016417	1	
5	Washer NL 8mm	611040	16	
6	Screw MC6S M8x40 12.9 ZFSHL	6000145	2	
7	O-ring 9,92x2,62	710968	4	QTY: 8 for option Wide
8	Tilt axle EC219	1064196	2	
9	Screw MC6S M16x90 12.9 ZFSHL	6000151	14	Torque: 333Nm
10	Magnet spacer tilt axle	1064202	1	For EC219S
11	Screw MC6S M4x14 8,8 FZB	610420	1	For EC219S
12	Cover Tilt Axle EC219 Cast	1065799	1	For EC219S
13	Protection plate tiltaxle EC219	1064717	1	For EC219/EC219PS Face the groove downwards
14	Screw MC6S M8x20 12.9 ZFSHL	6000157	6	

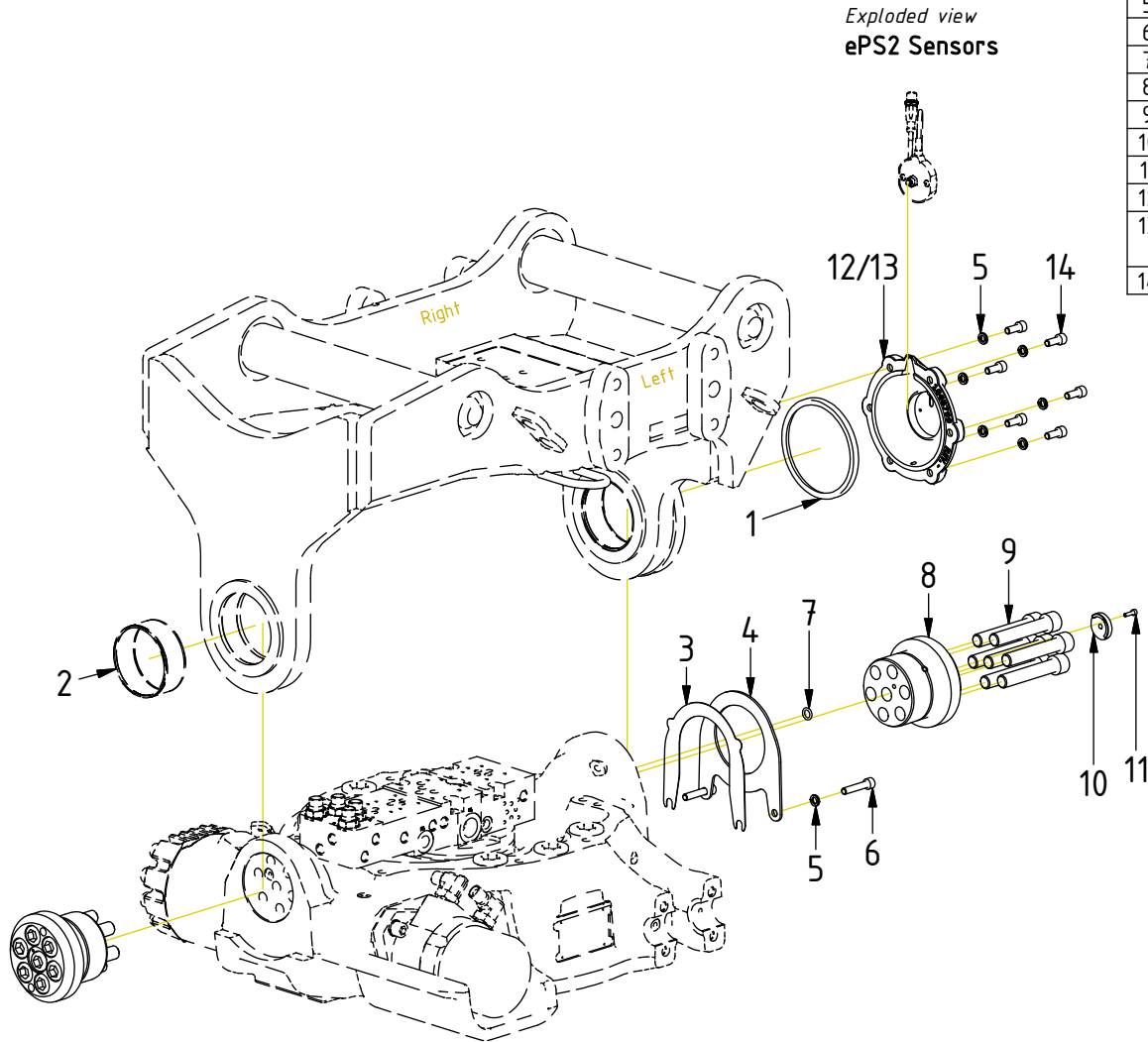

EC219 QSM - Std. Top components

Standard

Exploded view
Tilt cylinder

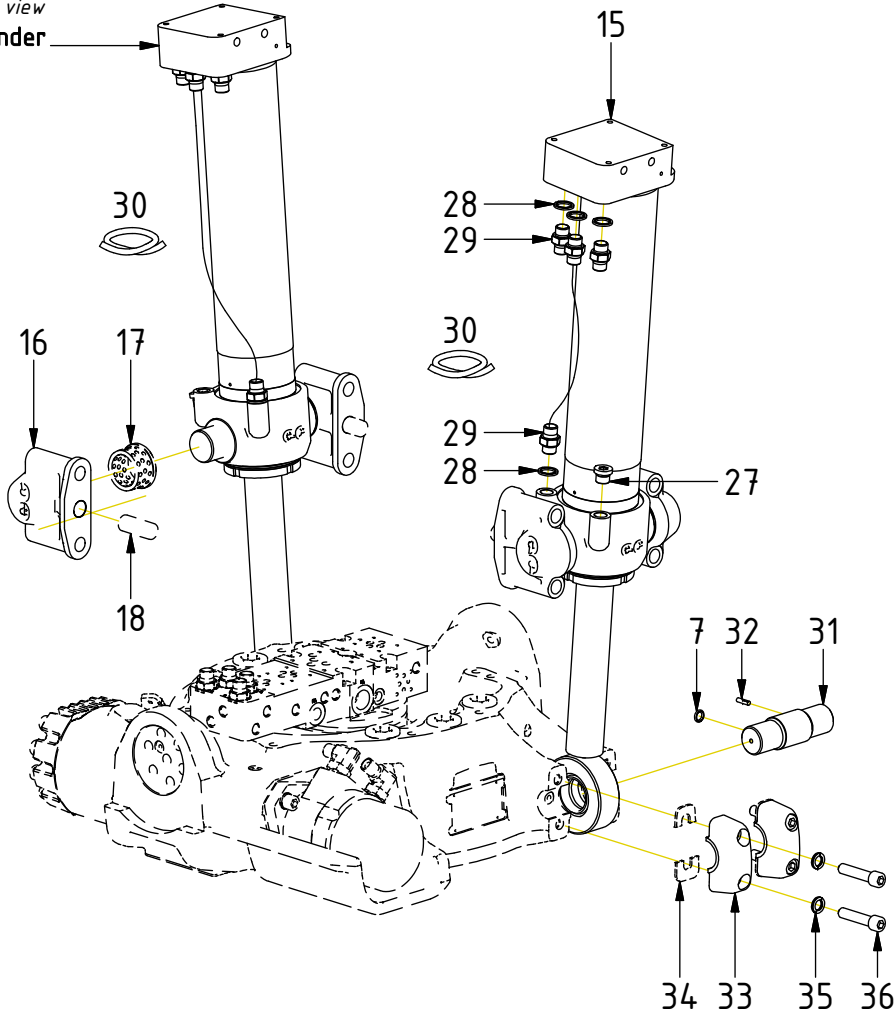

POS	DESCRIPTION	PART	QTY	COMMENTS
7	O-ring 9,92x2,62	710968	4	QTY: 8 for option Wide
15	Tilt cylinder EC219	1070275	2	
16	Yoke EC219 complete	1017151	4	(POS.17-18 incl.)
17	Bushing 40/50/55/5-30	631001	4	
18	Cylindrical pin \varnothing 20x50	650211	4	
20	For EC-Oil (no terminals) For Feed 3/4" (option)			See "Top part"
21	Spacer 20mm	1023777	4	
22	Hose terminal Left V2	1047137	1	
23	Hose terminal Right V2	1047138	1	
24	Screw MC6S M16x130 12.9 ZFSHL	6000154	4	Torque: 333Nm
25	For option DX			See p.10 for instruction
26	Screw MC6S M16x100 12.9 ZFSHL	6000156	4	Torque: 333Nm
27	Plug 70125-06 (3/8")	711504	2	
28	Washer GBR06 3/8	710703	8	
29	Adapter 136-06-06 (3/8")	710106	8	
30	Hose Tilt Short	742606	2	
31	Cylinder axle \varnothing 40	1016398	2	
32	Slotted pin 5x20	640413	2	QTY: 4 for option Wide
33	Clamping half 35 Complete	1016393	4	(POS.34 incl.)
34	Rubber spacer clamping half	1016439	4	
35	Washer NL 12mm	611042	8	
36	Screw MC6S M12x55 12.9 ZFSHL	6000155	8	Torque: 136Nm
37	Shim Yoke bracket	1007041	4	For option Shimmed Tilt cyl.
38	Screw MC6S M16x140 12.9 ZFSHL	6000152	4	Torque: 333Nm
39	Screw MC6S M16x110 12.9 ZFSHL	6000253	4	Torque: 333Nm

Std terminals

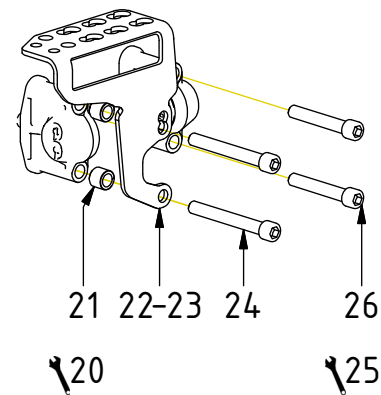

Shimmed Tilt cyl.

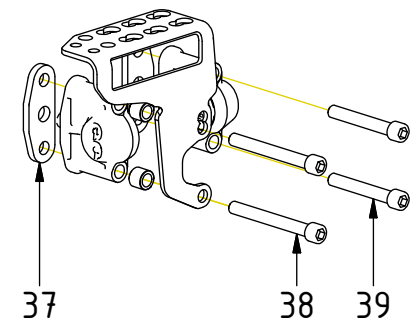

POS in order of assembly

Wide

Exploded view
Tilt cylinder

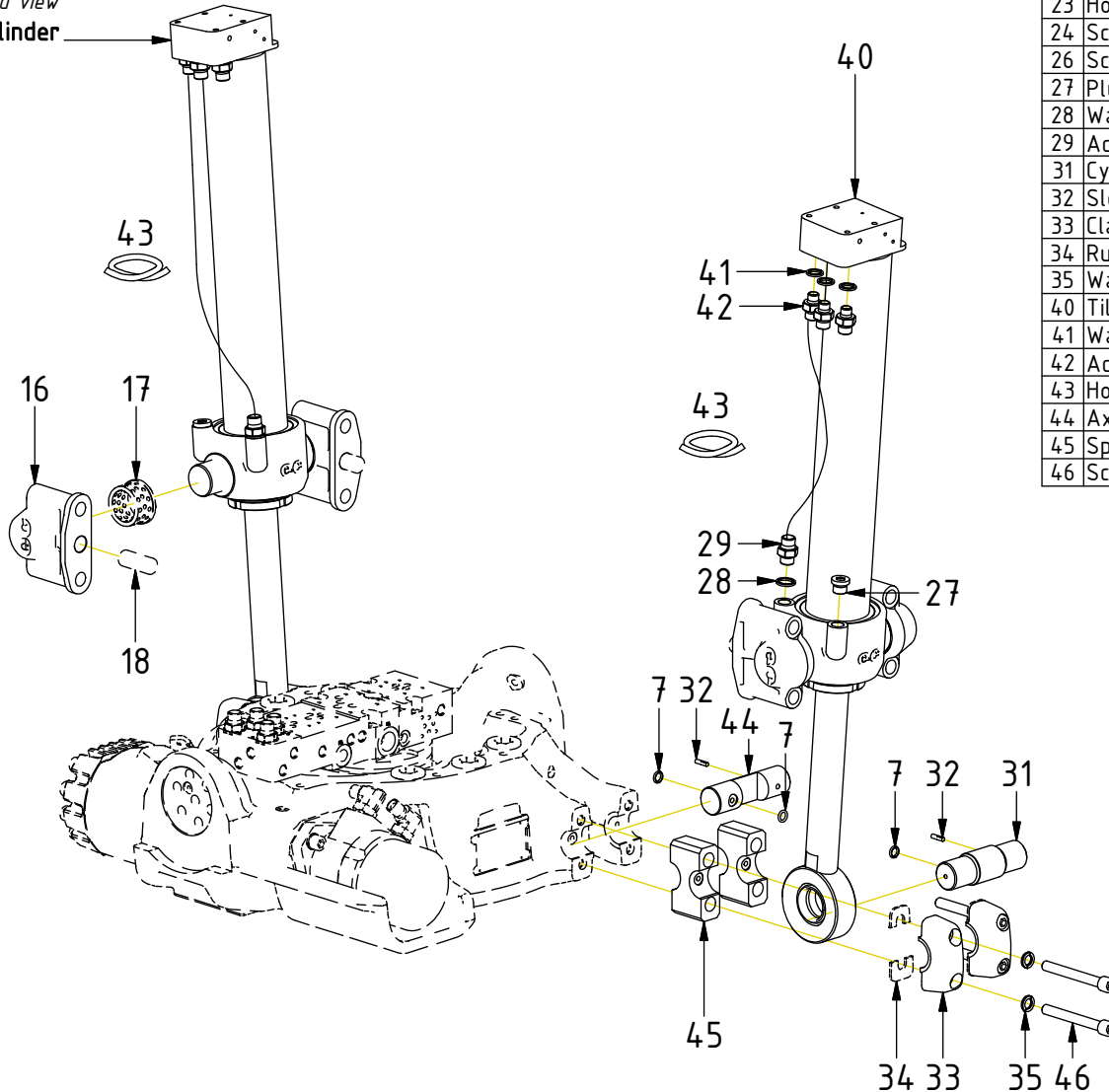

POS	DESCRIPTION	PART	QTY	COMMENTS
7	O-ring 9,92x2,62	710968	4	QTY: 8 for option Wide
16	Yoke EC219 complete	1017151	4	(POS.17-18 incl.)
17	Bushing 40/50/55/5-30	631001	4	
18	Cylindrical pin \varnothing 20x50	650211	4	
19	For Feed 3/4" (option)			See "Top part"
21	Spacer 20mm	1023777	4	
22	Hose terminal Left V2	1047137	1	
23	Hose terminal Right V2	1047138	1	
24	Screw MC6S M16x130 12.9 ZFSHL	6000154	4	Torque: 333Nm
26	Screw MC6S M16x100 12.9 ZFSHL	6000156	4	Torque: 333Nm
27	Plug 70125-06 (3/8")	711504	2	
28	Washer GBR06 3/8	710703	8	
29	Adapter 136-06-06 (3/8")	710106	8	
31	Cylinder axle \varnothing 40	1016398	2	
32	Slotted pin 5x20	640413	2	QTY: 4 for option Wide
33	Clamping half 35 Complete	1016393	4	(POS.34 incl.)
34	Rubber spacer clamping half	1016439	4	
35	Washer NL 12mm	611042	8	
40	Tilt cylinder EC219 Wide	1023811	2	
41	Washer GBR04 1/4	710702	8	
42	Adapter 135-04-06 (1/4"-3/8")	710118	6	
43	Hose Tilt Short Wide	7000563	2	
44	Axle for spacer Wide	1016534	2	
45	Spacer tilt cylinder Wide	1016533	4	
46	Screw MC6S M12x100 12.9 ZFSHL	611514	8	Torque: 136Nm

Std terminals

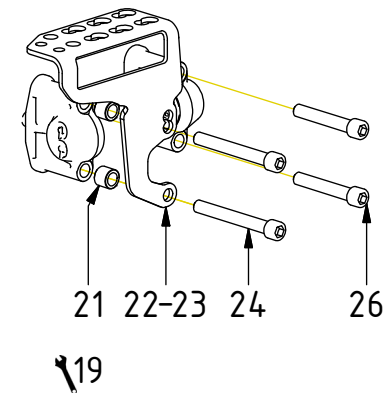

TILT
Standard

POS	DESCRIPTION	PART	QTY	COMMENTS
5	Washer NL 8mm	611040	16	
47	Hose Tilt Long	7000027	4	
48	Overcentre valve 4:1	730277	4	Torque: 60Nm
49	Hose protection Tiltcylinder	1014280	2	
50	Screw M6S M8x16 8,8 FZB	610122	8	

POS in order of assembly

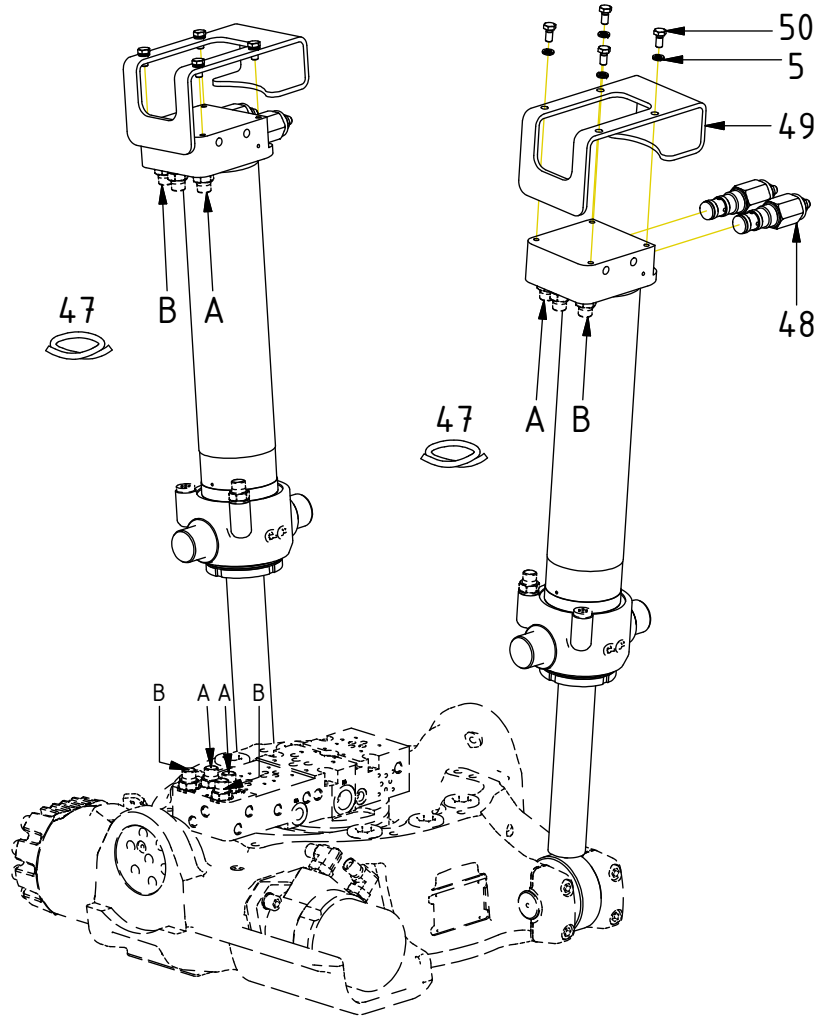

EC219 QSM - Std. Top components

TILT
Wide

POS	DESCRIPTION	PART	QTY	COMMENTS
5	Washer NL 8mm	611040	16	
51	Hose Tilt Long Wide	7000031	4	
52	Plug 1/4"	711505	4	
53	Overcentre valve 10:1 adjustable	730269	Torque: 60Nm	
54	Hose protection Tiltcylinder Wide	1003774	2	
55	Screw M6S M8x14 8,8 FZB	610188	8	

POS in order of assembly

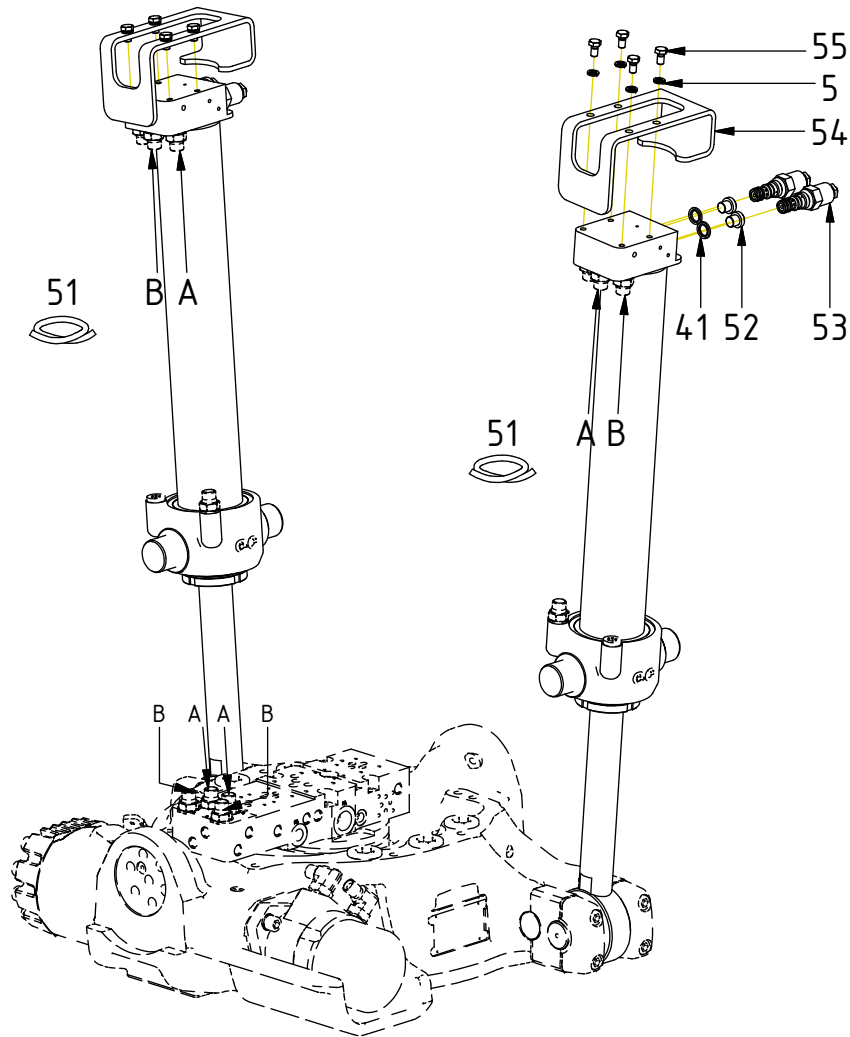

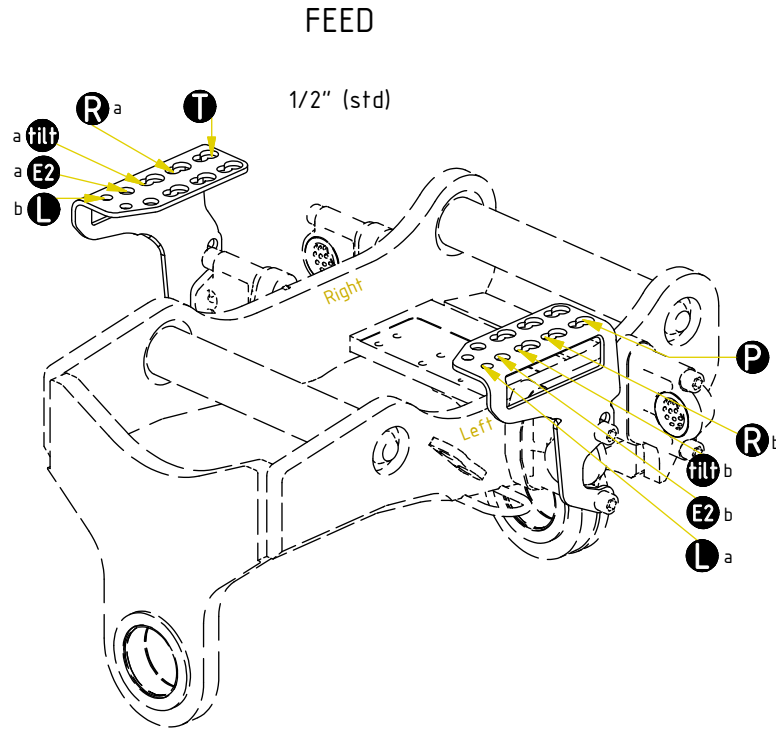
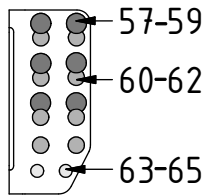

POS	DESCRIPTION	PART	QTY	COMMENTS
20	For EC-Oil (no terminals) For Feed 3/4" (option)			See "Top part"
25	For option DX			See p.10 for instruction
56	For Functions & Feed Hoses			See "Control system"
57	Washer NL 20mm	611098	2	
58	Adapter 1260-08-08 (1/2")	710244	2	
59	Counternut 1270-08 (1/2")	710254	2	
60	Washer NL 16mm	611044	2	
61	Adapter 1260-06-32 (3/8")	710242	2	
62	Counternut 1270-06 (3/8")	710252	2	
63	Washer NL 1/2"	611096	2	
64	Adapter 1260-04-04 (1/4")	710240	2	
65	Counternut 1270-04 (1/4")	710250	2	

Feed Left

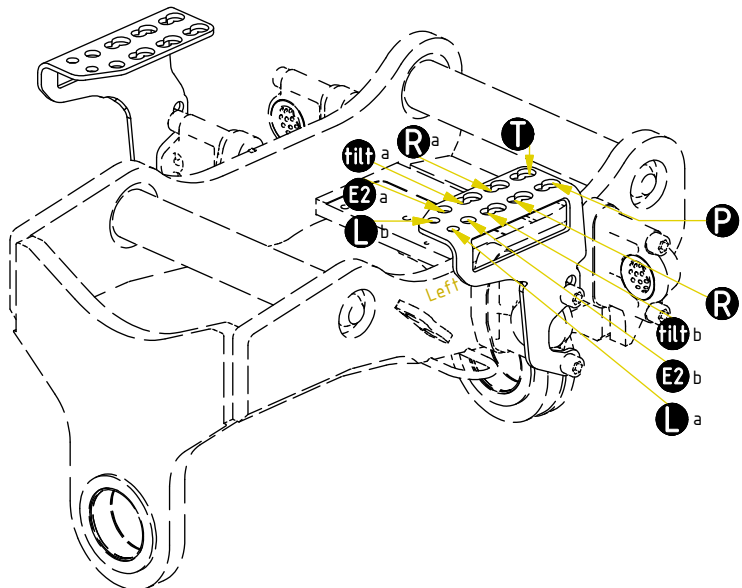

Feed Right

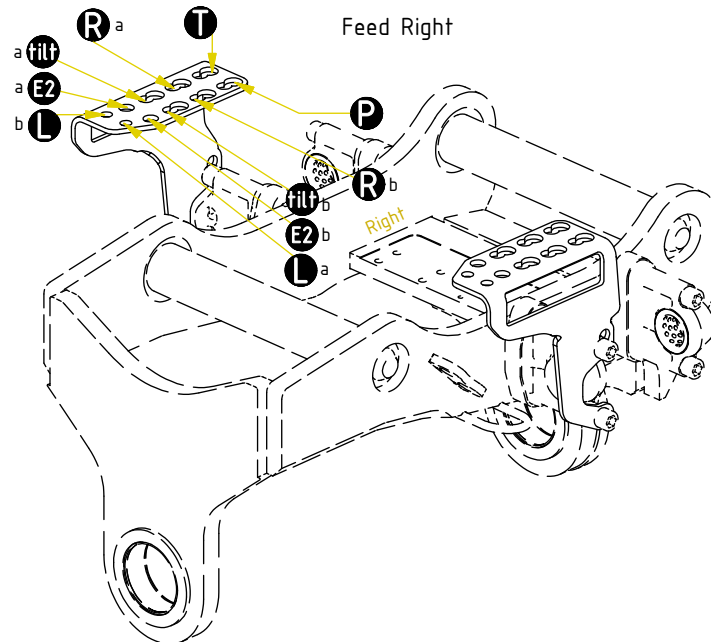

POS in order of assembly

TILT
Standard

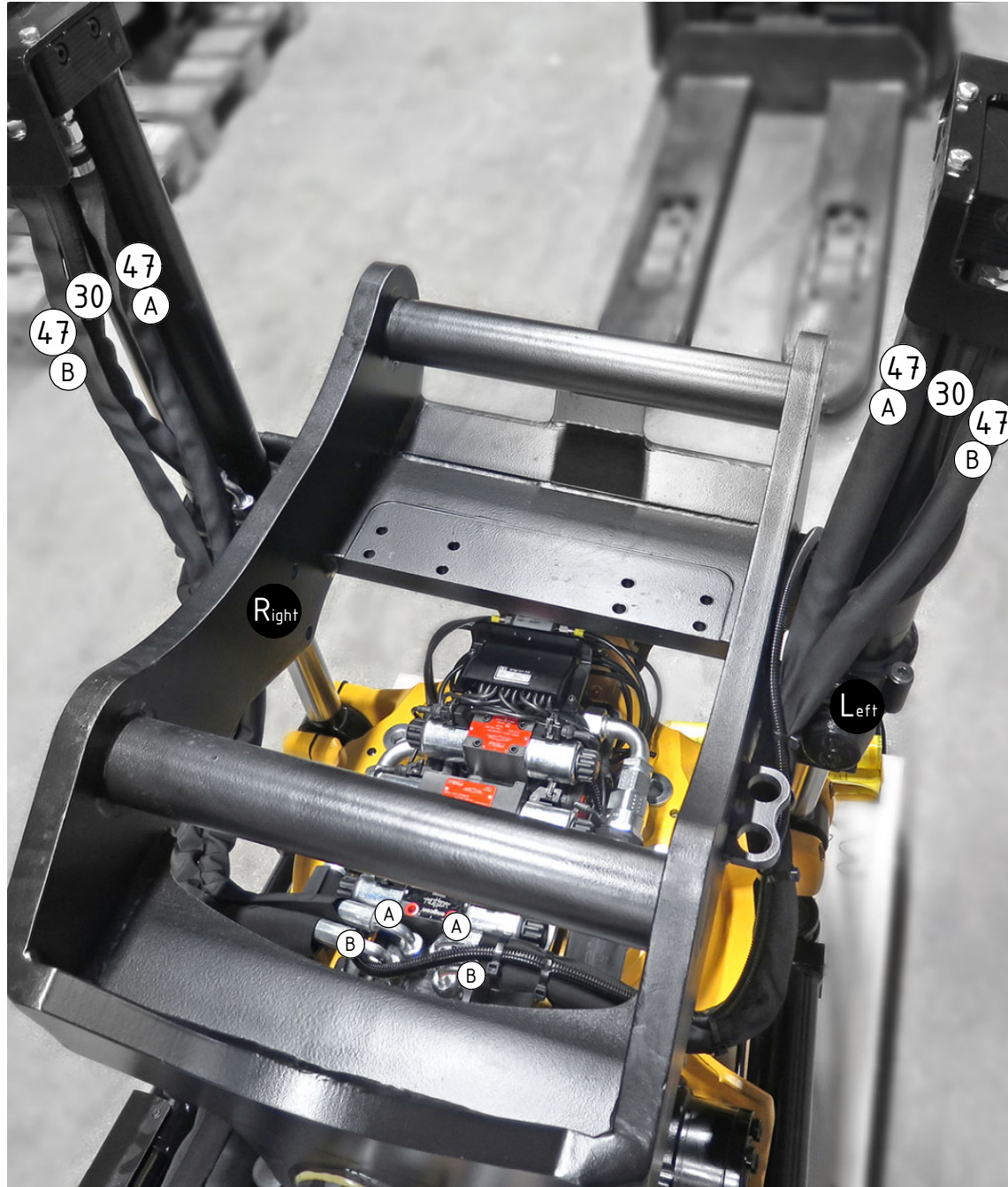

POS	DESCRIPTION	PART	QTY	COMMENTS
30	Hose Tilt Short	742606	2	
43	Hose Tilt Short Wide	7000563	2	
47	Hose Tilt Long	7000027	4	
51	Hose Tilt Long Wide	7000031	4	

Wide

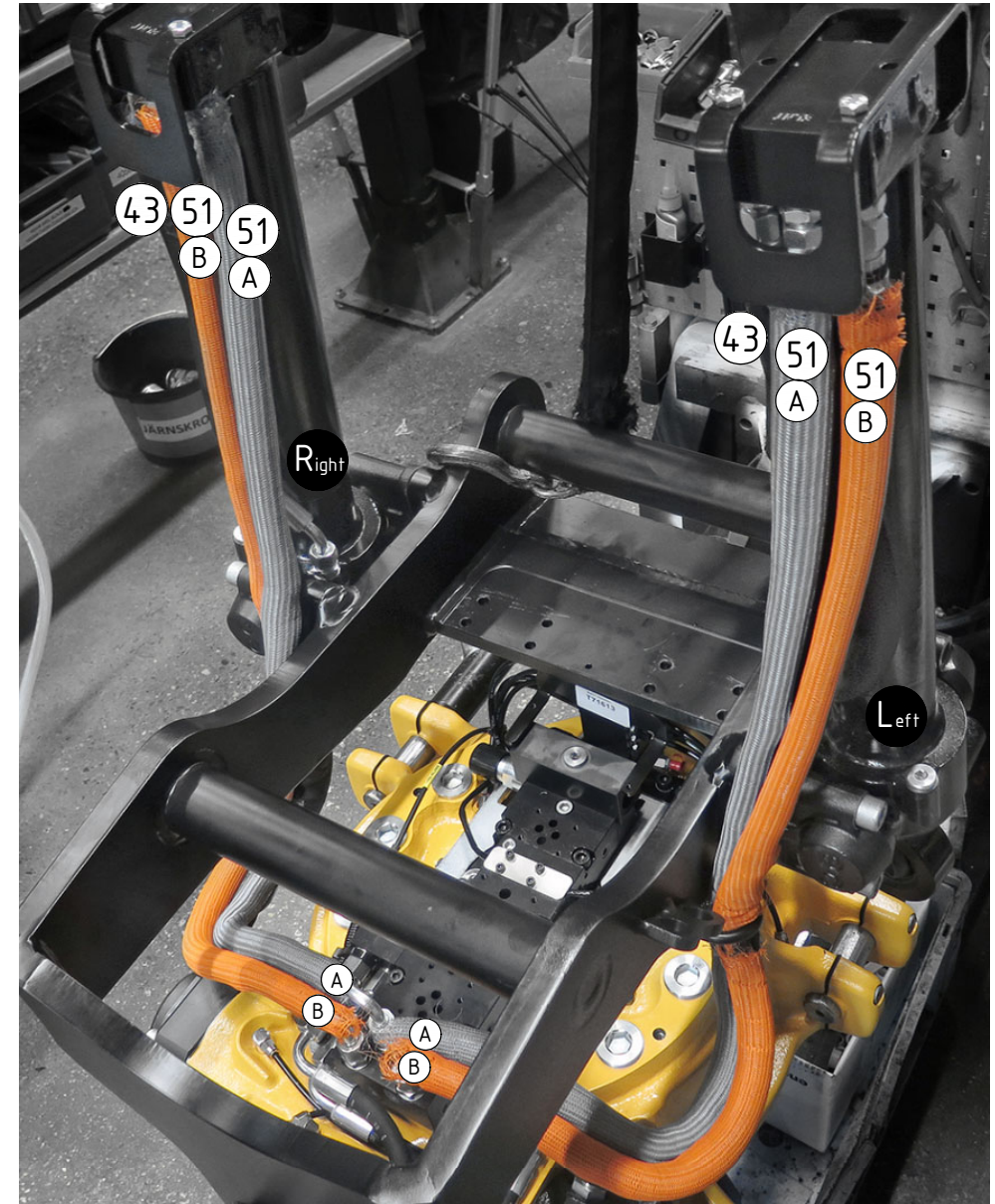

POS in order of assembly

FEED
1/2" (std)

POS	DESCRIPTION	PART	QTY	COMMENTS
20	For EC-Oil (no terminals) For Feed 3/4" (option)			See "Top part"
56	For Functions & Feed Hoses			See "Control system"

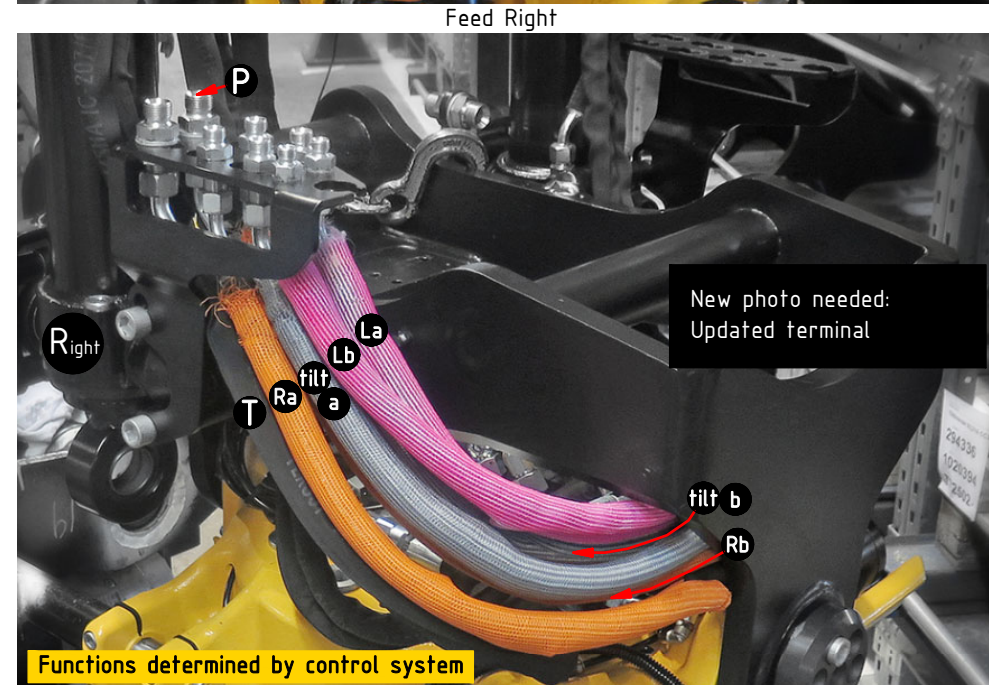
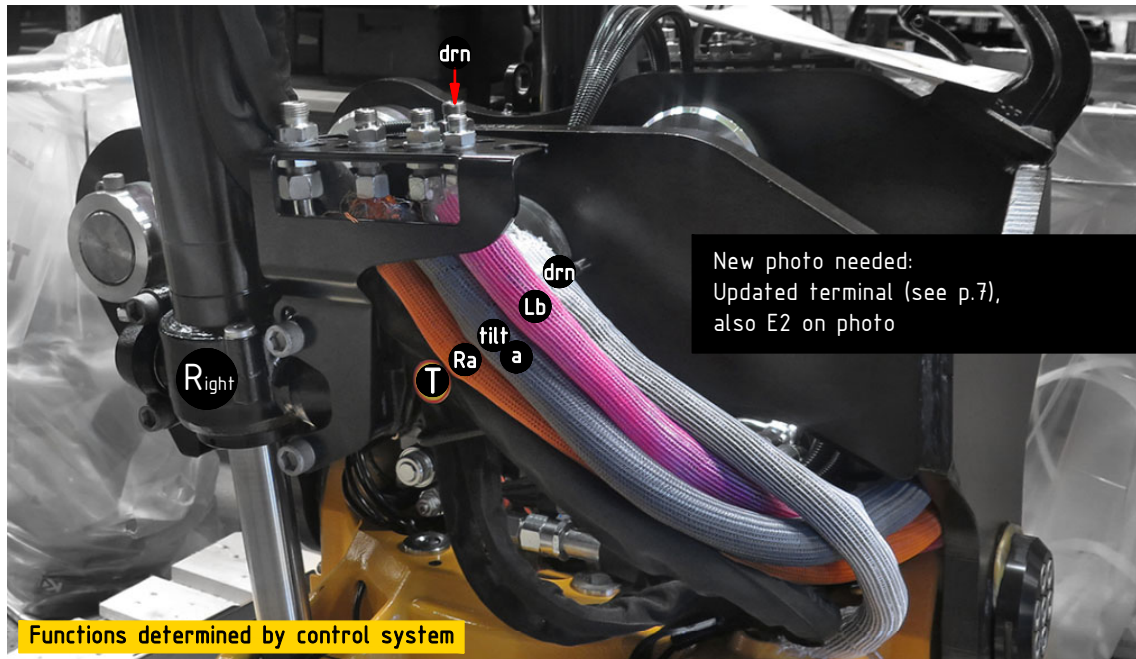
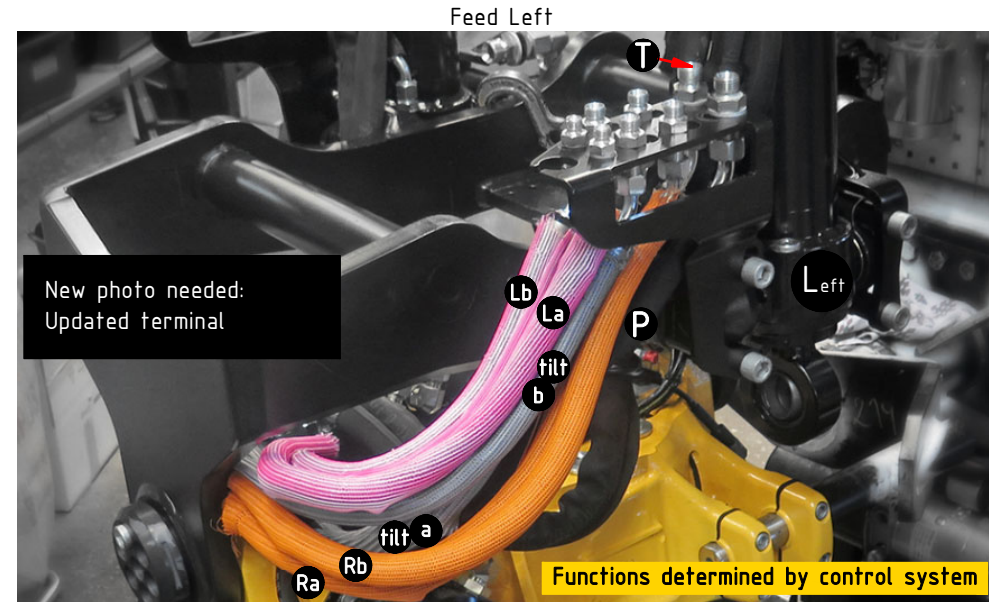
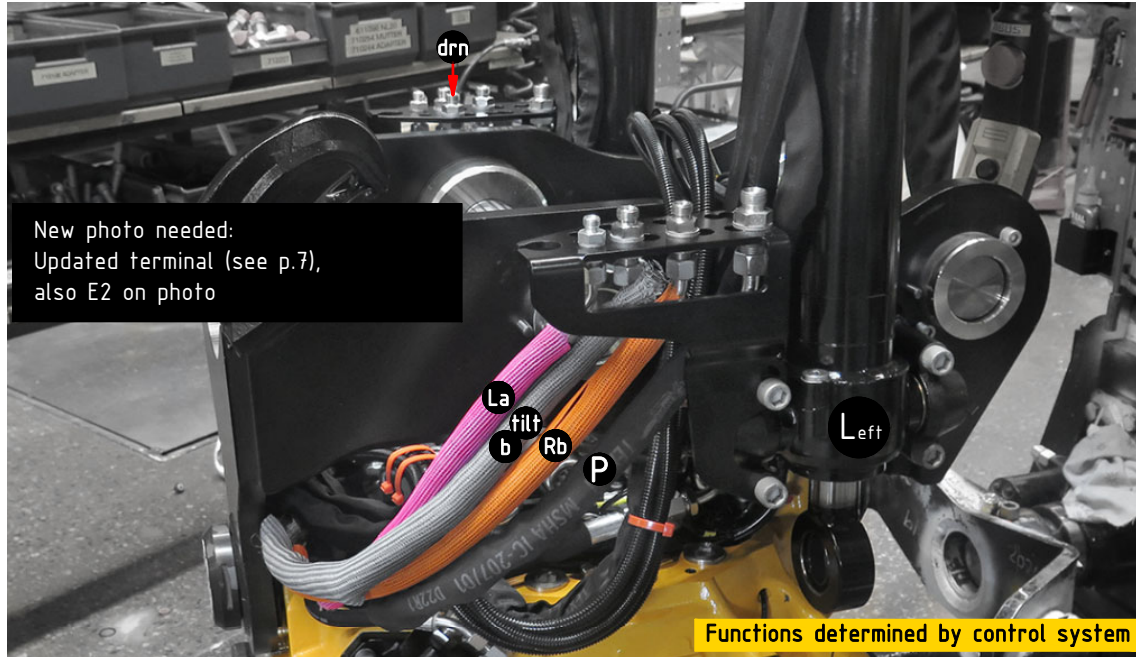

special/options

POS	DESCRIPTION	PART	QTY	COMMENTS
38	Screw MC6S M16x140 12.9 ZFSL	6000152	4	Torque: 333Nm
66	Spacer 28mm	1030616	4	
67	Hose terminal QS DX	1027200	2	
68	Washer NL1"-DPE 27,9x39x3,4	611095	2	
69	Adapter bulkhead 1260-12-12	712210	2	
70	Nut bulkhead adapter 1270-12	712211	2	

POS in order of assembly

DX on QS

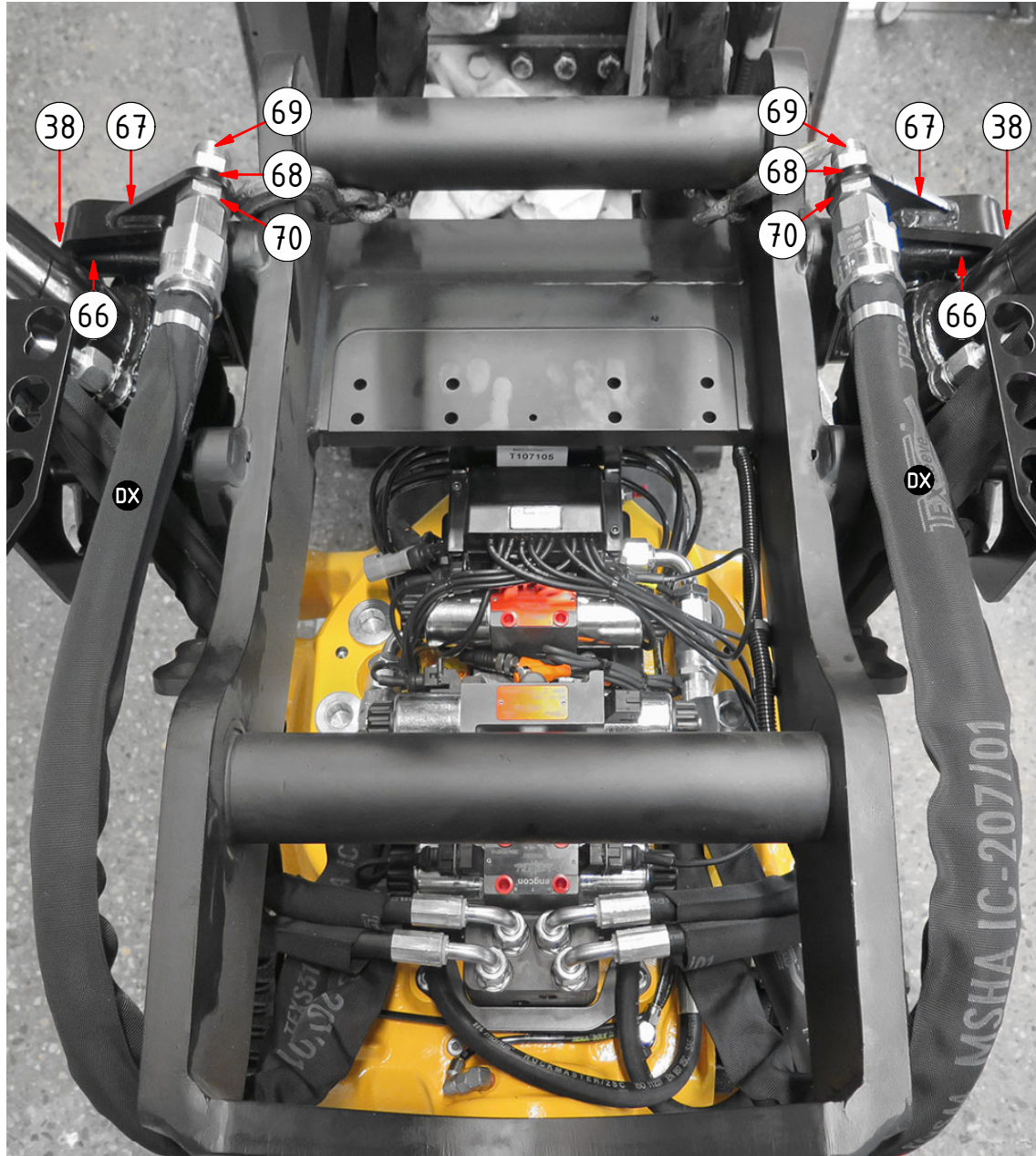

DX on UNI

