

COVERSHEET

Planned document changes:

Briefly:

2025-03-10. Add to POS.29: Torque 136Nm.

Document changes:

Date:	Change:	Rev. after change:
2025-02-27	Photos added.	A
2024-10-14	New document.	-

Readers note:

 Indicates instruction.

 Represents Hose.

Dashed lines for overview, mounts
on other pages/assemblies.

Std. Hitch components - S45

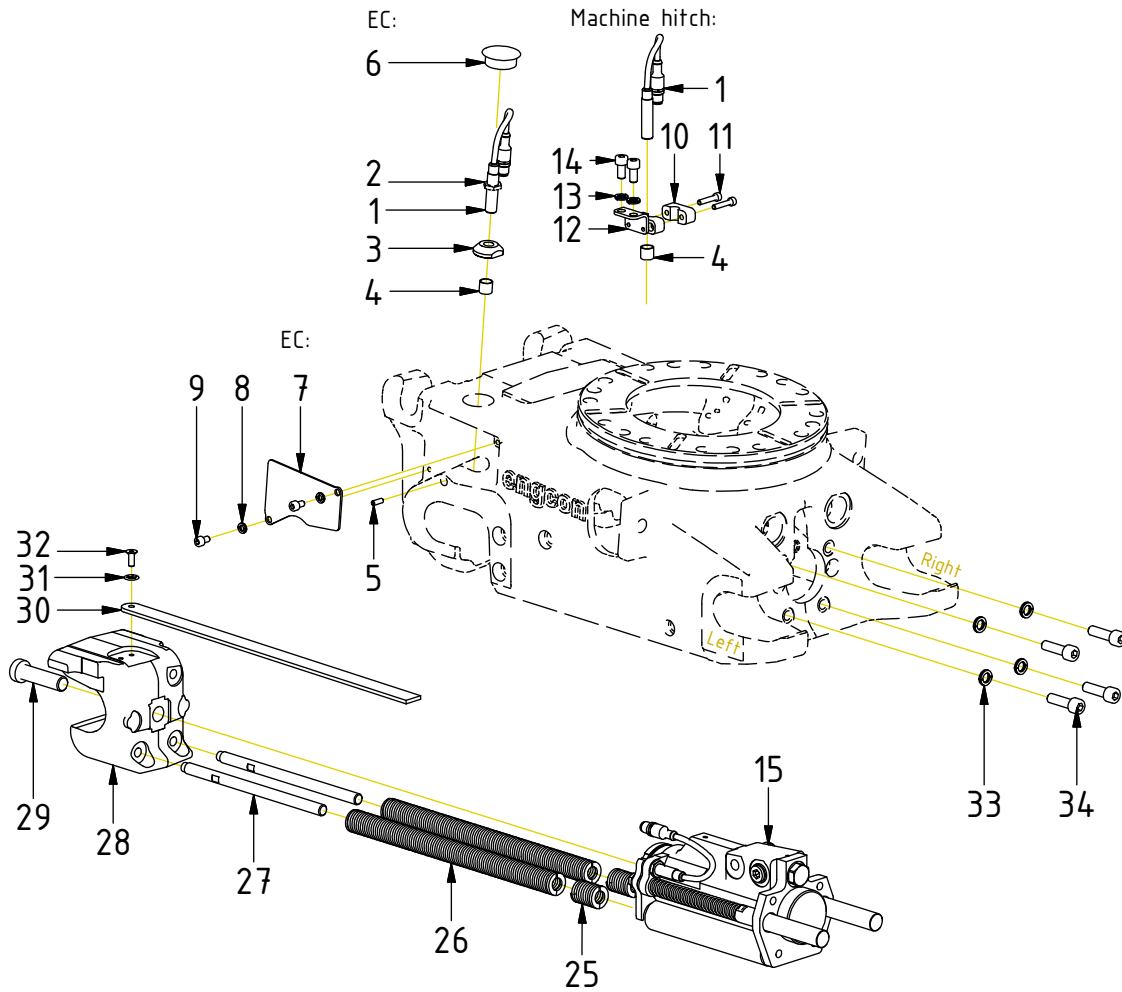

POS	DESCRIPTION	PART	QTY	COMMENTS
1	Inductive sensor QSM	1048262	2	EC: to slip ring. Machine: to Y-split
2	Hex nut			(Incl. with sensor)
3	Position nut, inductive sensor	1029432	1	
4	Protection lid, inductive sensor	8000056	1	
5	Set Screw M8x16	610808	1	
6	Cover plug QS/ECO	8000068	1	
7	Small cover plate QSM45 V2	1061548	2	
8	Washer NL 6mm	611039	4	
9	Screw MC6S M6x10 12.9 Geomet	611512	4	
10	Clamp half M12 sensor	1065219	2	
11	Screw MC6S M5x25 12.9	610402	2	
12	Sensor holder machine hitch	1074148	1	
13	Washer NL 8mm	611040	2	
14	Screw MC6S M8x16 12.9 ZFSHL	610432	2	
15	Lock cyl. QSM45 Compl. Forged QSC	1072390	1	(POS.1, 16-22 incl.)
16	Lock cylinder QSM45	1067280	1	
17	Spring QS45/50/60 Ejectors 16x175	1049973	2	
18	Ejector QS45	1036953	2	
19	Spacer	1036406	2	
20	Sensor Plate	1036988	1	Assemble with sligth play
21	Washer BRB 8,4x16x1,6 200 HV FZB	611005	2	
22	Screw M6S M8x30 8,8 FZB	611538	2	Loxéal 83-52
23	Washer GBR04 1/4	710702	2	
24	Plug 153-04 (1/4")	711505	2	
25	Spring 25x32	1025483	2	
26	Spring 25x305	1024021	2	
27	Steering	1025621	2	Loxéal 83-52
28	Hook QS45 V2 machined	1047545	1	
29	Screw MLC6S M16x60 10.9	610721	1	Loxéal 83-52
30	Indicator pin QS, 605mm	1036201	1	Cut to fit
31	Washer Starlock 6mm	6000415	1	
32	Screw MF6S M6x16 10.9 untreatead	610604	1	Loxéal 83-52
33	Washer NL 10mm	611041	4	
34	Screw MC6S M10x35 12.9	610494	4	

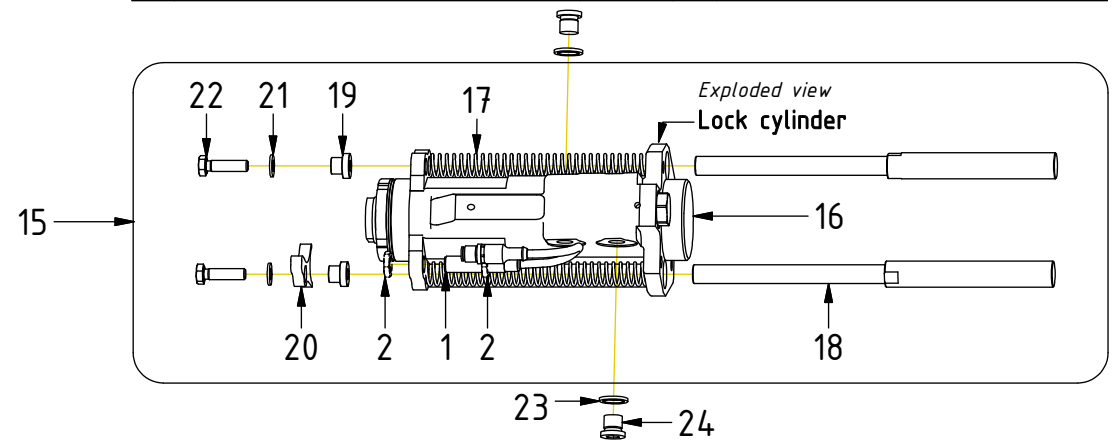

POS in order of assembly

Sensor Cylinder

EC3, Machine hitch

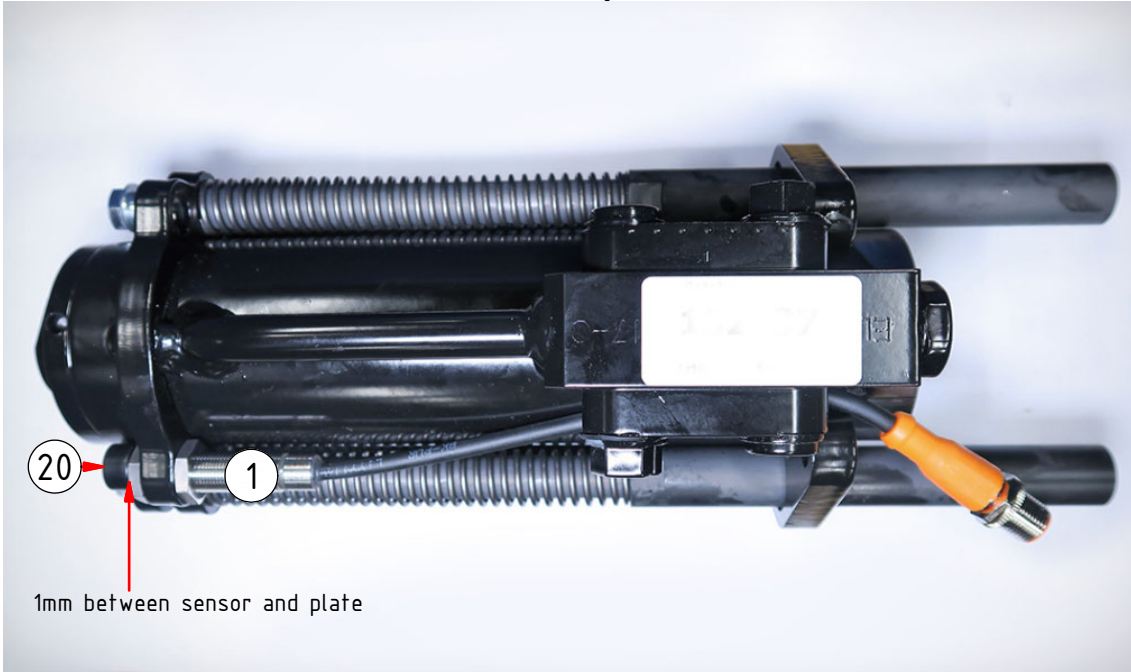

POS	DESCRIPTION	PART	QTY	COMMENTS
1	Inductive sensor QSM	1048262	2	EC: to slip ring. Machine: to Y-split
5	Set Screw M8x16	610808	1	
20	Sensor Plate	1036988	1	Assemble with sligth play
35	Rubber Steel Clamp Ø12	790155	1	
36	Screw MC6S 5x16 12.9	610401	1	
37	In machine hitch sensors positions varies per control system			See "Machine hitch" for photos
	● Use cable ties			

POS in order of assembly

ECO Cable EC



Sensor Hook EC

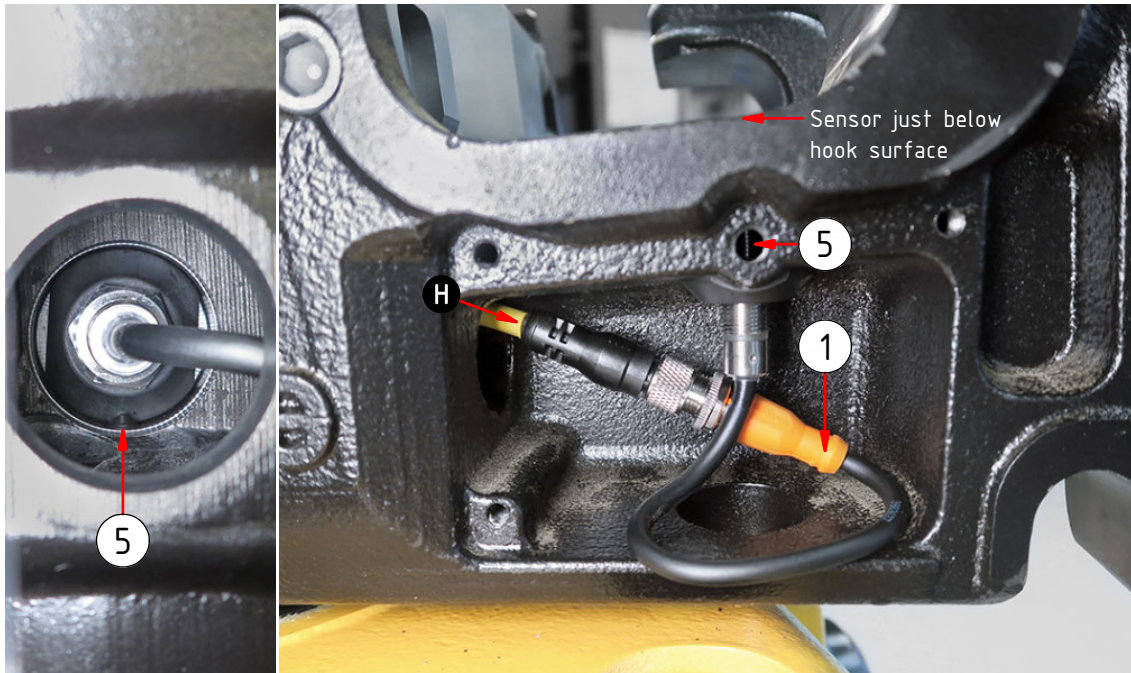

37

Sensor Cables EC

