

COVERSHEET

Planned document changes:

Briefly:

No planned changes.

Document changes:

Date:	Change:	Rev. after change:
2025-01-17	ss0 spacers added.	B
2024-11-07	New document.	A
2024-04-29	Pre-series draft.	-

Readers note:

 Indicates instruction.

 Represents Hose.

Dashed lines for overview, mounts
on other pages/assemblies.

EC204B - Std. Top components

EC204BS:
Exploded view
ePS2 Sensors

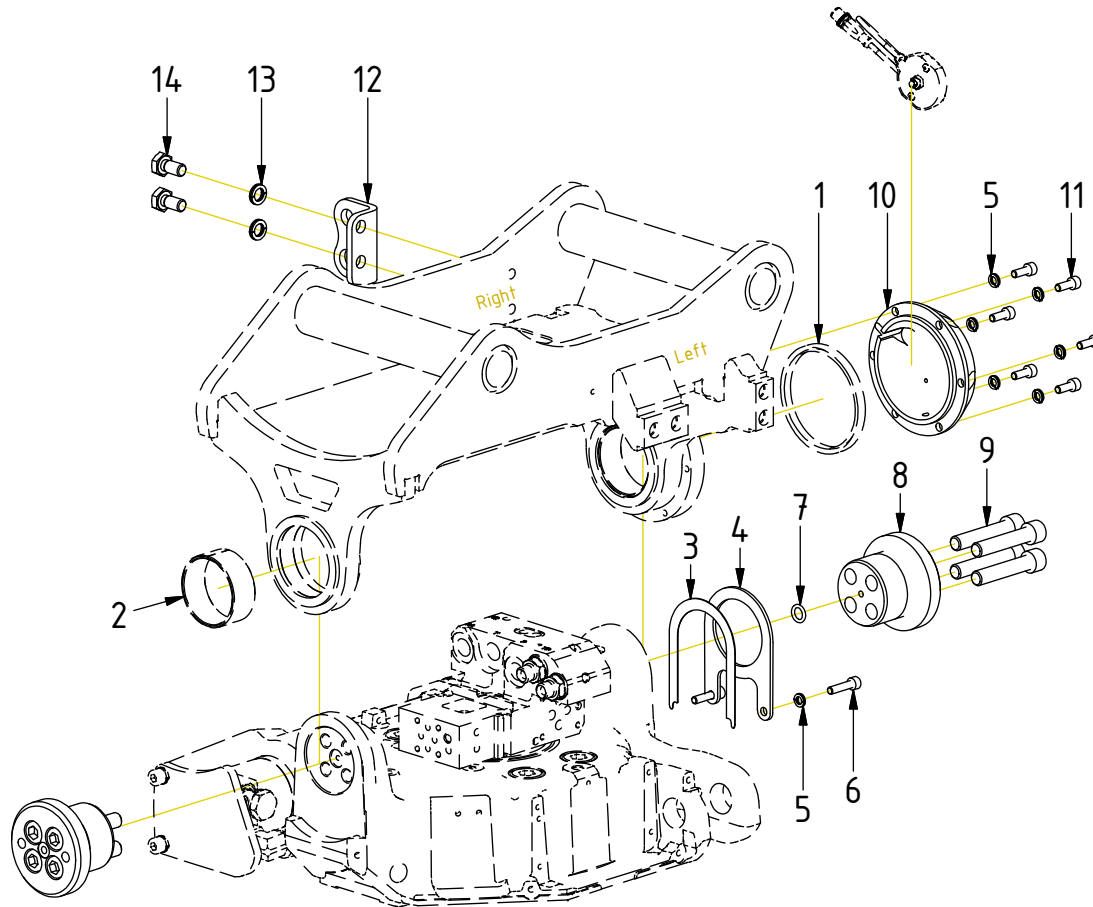

POS	DESCRIPTION	PART	QTY	COMMENTS
1	SEAL SKF PAK 80x90x7-L	1076113	1	NB! Face groove toward top part (Incl. in Top part)
2	Bushing 55/60x25 WB802	6000004	2	(Incl. in Top part)
3	Shim tilt axle	1027820	1	Use as required
4	Axial washer tilt	1027785	1	
5	Washer NL 6mm	611039	22	
6	Screw MC6S M6x25 12.9	6000083	2	
7	O-ring 9,92x2,62	710968	2	
8	Tilt axle EC204B	1074348	2	
9	Screw MC6S M12x60 12.9 ZFSL	6000140	10	Torque: 136Nm QTY: 8 when EC-Oil
10	Cover Tilt axle EC204B	1074349	1	
11	Screw MC6S M6x16 12.9 ZFSL	6000017	8	
12	Hose terminal EC204 right	1045070	1	Without EC-Oil
13	Washer NL 10mm	611041	2	Without EC-Oil
14	Screw M6S M10x20 8,8 FZB	610141	2	

EC204B - Std. Top components

POS	DESCRIPTION	PART	QTY	COMMENTS
9	Screw MC6S M12x60 12.9 ZFSL	6000140	10	Torque: 136Nm QTY: 8 when EC-Oil
15	Tilt cylinder EC204B	1077744	1	
16	Valve block tilt cylinder	1075504	1	Part of control system
17	Washer GBR04 1/4	710702	2	
18	Adapter 138-04-29 (1/4")	710135	2	
19	Yoke EC204 rear compl.	1036606	1	(POS.21 incl.)
20	Yoke EC204 front compl.	1029052	1	(POS.21 incl.)
21	Bushing BWG-F 25/31/38/1,5x20	6000001	2	
22	For EC-Oil (no terminals)			See "Top part" QS40
23	Screw MC6S M12x40 12.9 ZFSL	6000141	2	Torque: 136Nm
24	Spacer yD=19 t=3 L=15	1009999	2	
25	Hose terminal EC204 Left - QS40	1053732	1	
26	Hose terminal EC204 Left - UNI	1079699	1	
27	Cylinder axle	1075902	1	
28	Washer NL 8mm	611040	1	
29	Screw MLC6S M8x16 10.9 FZB	6000220	1	
30	Spacer yD=19 t=3 L=10	1071704	2	
31	Hose guide EC204B	1078845	1	
32	Screw MC6S M12x55 12.9 ZFSL	6000155	2	Torque: 136Nm

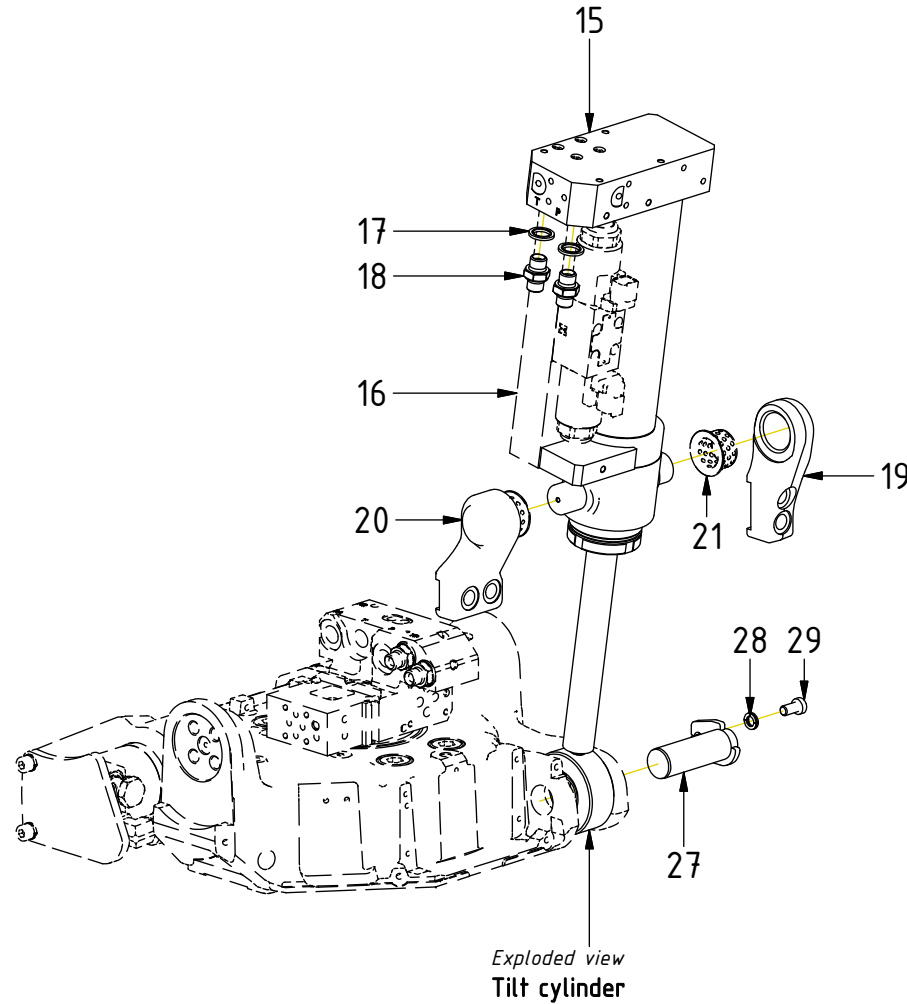

Std terminals

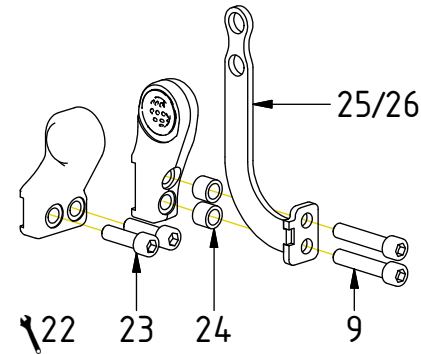

ss0

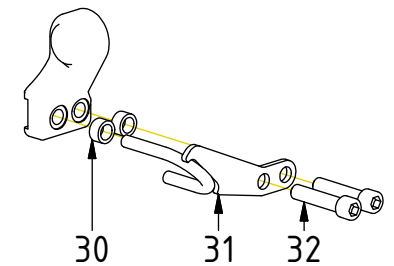

POS in order of assembly

EC204B - Std. Top components

POS in order of assembly

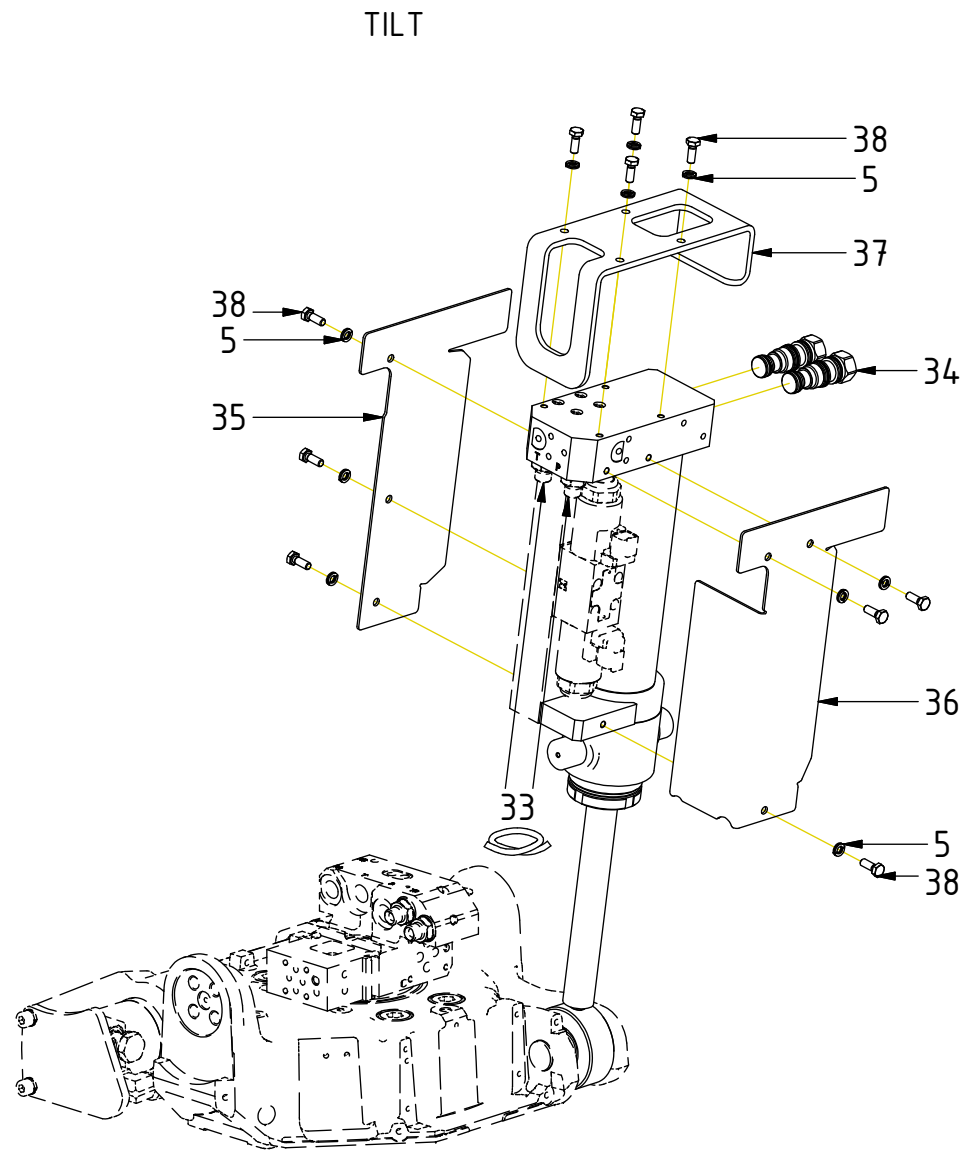

POS	DESCRIPTION	PART	QTY	COMMENTS
5	Washer NL 6mm	611039	22	
33	Hose Tilt	7001990	2	For DC2, ss9
34	Overcenter valve	7000647	2	Torque: 45Nm
35	Cover tilt cylinder Right	1076686	1	
36	Cover tilt cylinder Left	1076687	1	
37	Hose protection Tiltcylinder	1075507	1	
38	Screw M6S M6x16 10.9 untreated	610109	10	

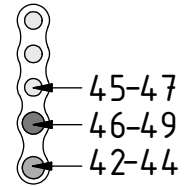
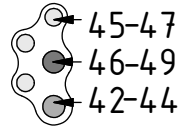
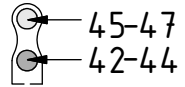
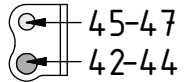

FEED

POS	DESCRIPTION	PART	QTY	COMMENTS
22	For EC-Oil (no terminals)			See "Top part" QS40
39	For Functions & Feed Hoses			See "Control system"
40	Terminal extender 2x3/8, 3x1/4	1079468	1	
41	Terminal extender 2x3/8, 3x1/4	1079464	1	
42	Washer NL 16mm	611044	2	
43	Adapter 1260-06-32 (3/8")	710242	2	
44	Counternut 1270-06 (3/8")	710252	2	
45	Adapter 1260-04-04 (1/4")	710240	2	QTY depends on config.
46	Counternut 1270-04 (1/4")	710250	2	QTY depends on config.
47	Washer NL 1/2"	611096	2	QTY depends on config.
48	O-ring 12,37x2,62	710961	2	
49	Adapter 1260-04-40 (1/4")	710261	2	

