

## COVERSHEET

## Planned document changes:

**Briefly:**

2024-05-14. Add seal kit 7001495. (Contains seals and o-rings).

2023-09-20. POS.6 replaced by 6000406. New torque: 9,8Nm.

## Document changes:

**Date:****Change:****Rev.****after change:**

2023-05-25 New document.

-

*Readers note:*

Indicates instruction.



Represents Hose.

Dashed lines for overview, mounts  
on other pages/assemblies.

# Connection block & Swivel QSM60

POS in order of assembly

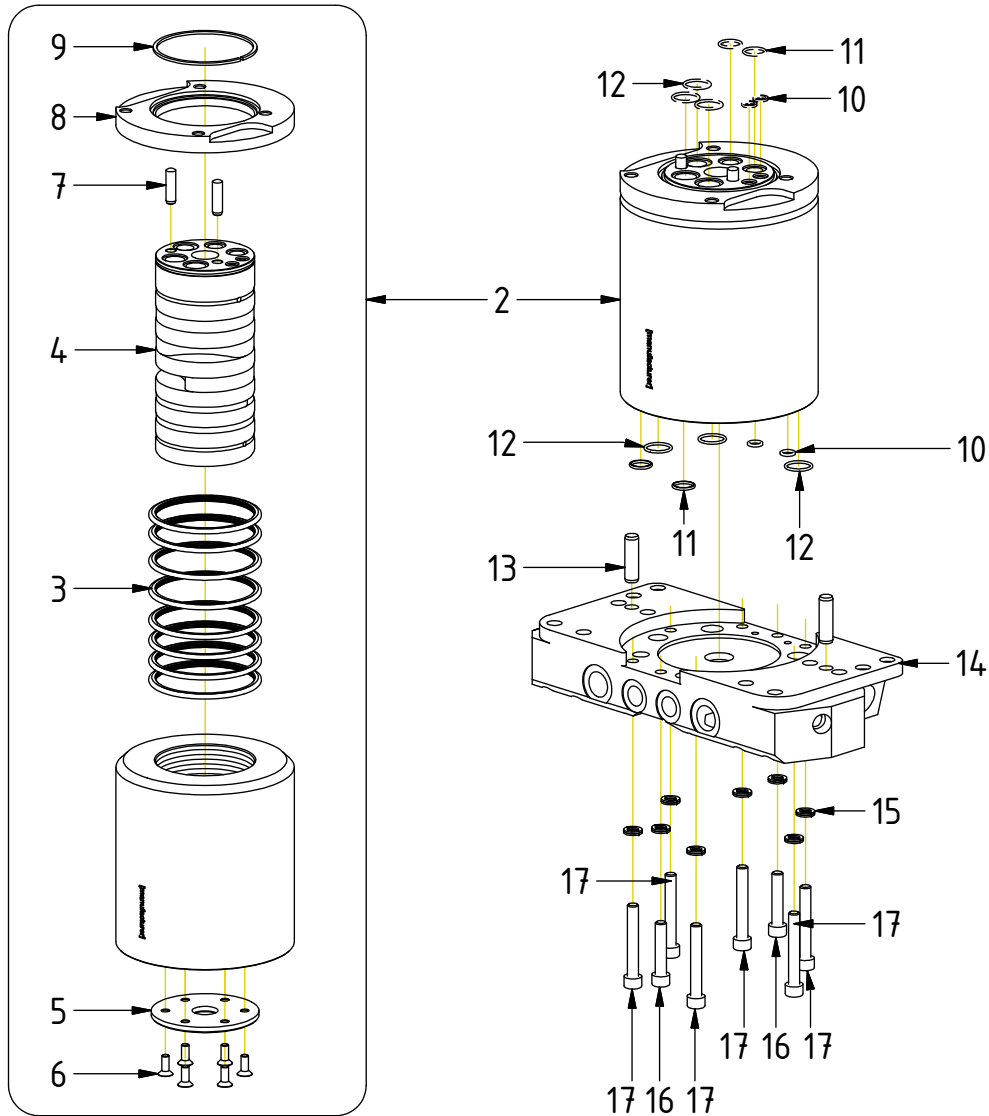

POS	DESCRIPTION	PART	QTY	COMMENTS
1	Connectionbl. & Swivel 7-ch QSM60	1050600	1	(POS.2, 10-17 incl.)
2	Swivel 7-ch QSM60/70 Compl. Steel	1049276	1	(POS.3-9 incl.)
3	Swivel Sealing 80/91x4,2	1039544	8	
4	Swivel Piston QSM60/70	1046696	1	
5	Wear washer QSM60/70	1046697	1	
6	Screw MF6S 6x16	610604	6	Torque: 14Nm
7	Dowel pin CPK 8x30 m6	6000175	2	
8	Fastening ring swivel QSM60/70	1044052	1	
9	Snap ring 80/77,4 x2	1039555	1	
10	O-ring square 7,66x1,68	7000579	4	QTY: 2 part of quick hitch assy.
11	O-ring 14x1,78	710975	4	QTY: 2 part of quick hitch assy.
12	O-ring 17.17x1.78	710977	6	QTY: 3 part of quick hitch assy.
13	Cylindrical pin	1015672	2	
14	Connection block QSM60	1049290	1	
15	Washer NL 8mm	611040	8	
16	MC6S M8x40 12.9	610437	2	
17	MC6S M8x55 12.9	610588	6	