

## Planned document changes:

**Briefly:**

No planned changes.

## Document changes:

Date:	Change:	Rev. after change:
2023-08-22	Brush cassette quantity (QTY) corrected.	B
2023-07-03	Part nos for washers and screws corrected. Plug added.	A
2022-12-22	New document.	-

*Readers note:*

Indicates instruction.



Represents Hose.

Dashed lines for overview, mounts  
on other pages/assemblies.

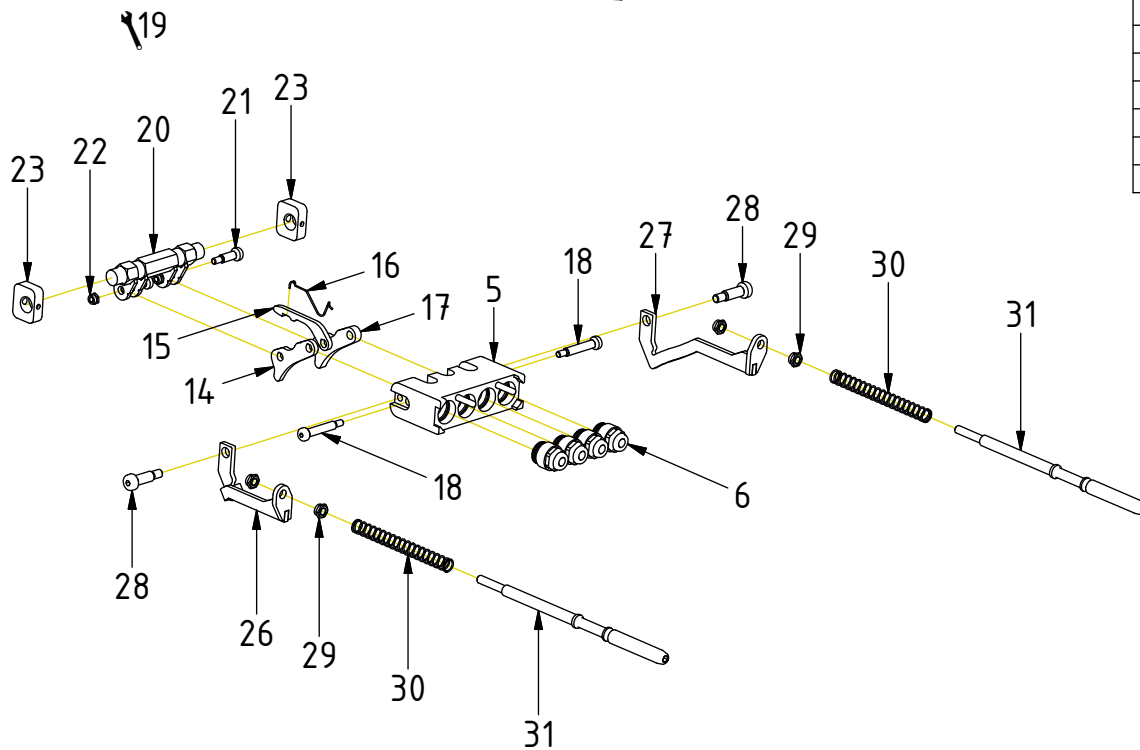
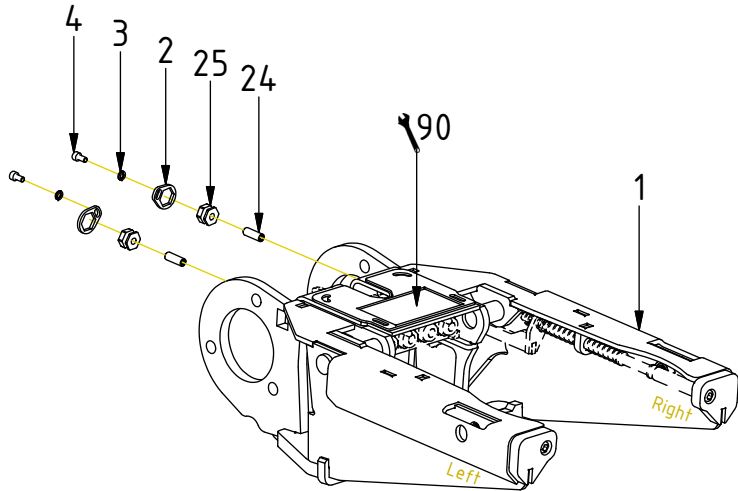

POS	DESCRIPTION	PART	QTY	COMMENTS
1	Frame SWD40	1067400	1	
2	Eccenter adjustment lock	1069266	2	
3	Washer NL 5mm	611038	2	
4	Screw MC6S M5x10 12.9	610594	2	
5	Q-block GRD40/SWD40	1063783	1	
6	Coupling ECO 1/4" male	1053693	4	Torque: 60Nm
14	Link arm thin	1069486	1	
15	Locking hasp	1069487	1	
16	Spring wire	1069471	1	
17	Link arm	1063772	1	
18	Shoulder bolt 8x40/M6	6000264	2	
19	With Q-block retracted, grooves on ecenter must be facing Q-block			See p.7 for instruction
20	Eccenter GRD40/SWD40	1063841	1	
21	Shoulder bolt 8x20/M6	6000367	2	
22	Lock Nut M6M M6x1 8,8 FZB	610921	2	
23	Eccenter holder GRD40/SWD40	1063860	2	
24	Set screw M8x25 DIN914	6000012	2	Loxeal 83-52
25	Adjustment nut GRD40/SWD40	1063862	2	
26	Carrier Left GRD40/SWD40	1063516	1	
27	Carrier Right GRD40/SWD40	1063518	1	
28	Shoulder bolt 10x25/M8	611703	2	Loxeal 83-52
29	Lock Nut M6M M8x1,25 8,8 FZB	610922	10	QTY: 6 part of brush holders
30	Spring DIN 2098	1038762	2	
31	Lock arm GRD40/SWD40	1063497	2	
90	Punch serial no into fame			

POS in order of assembly

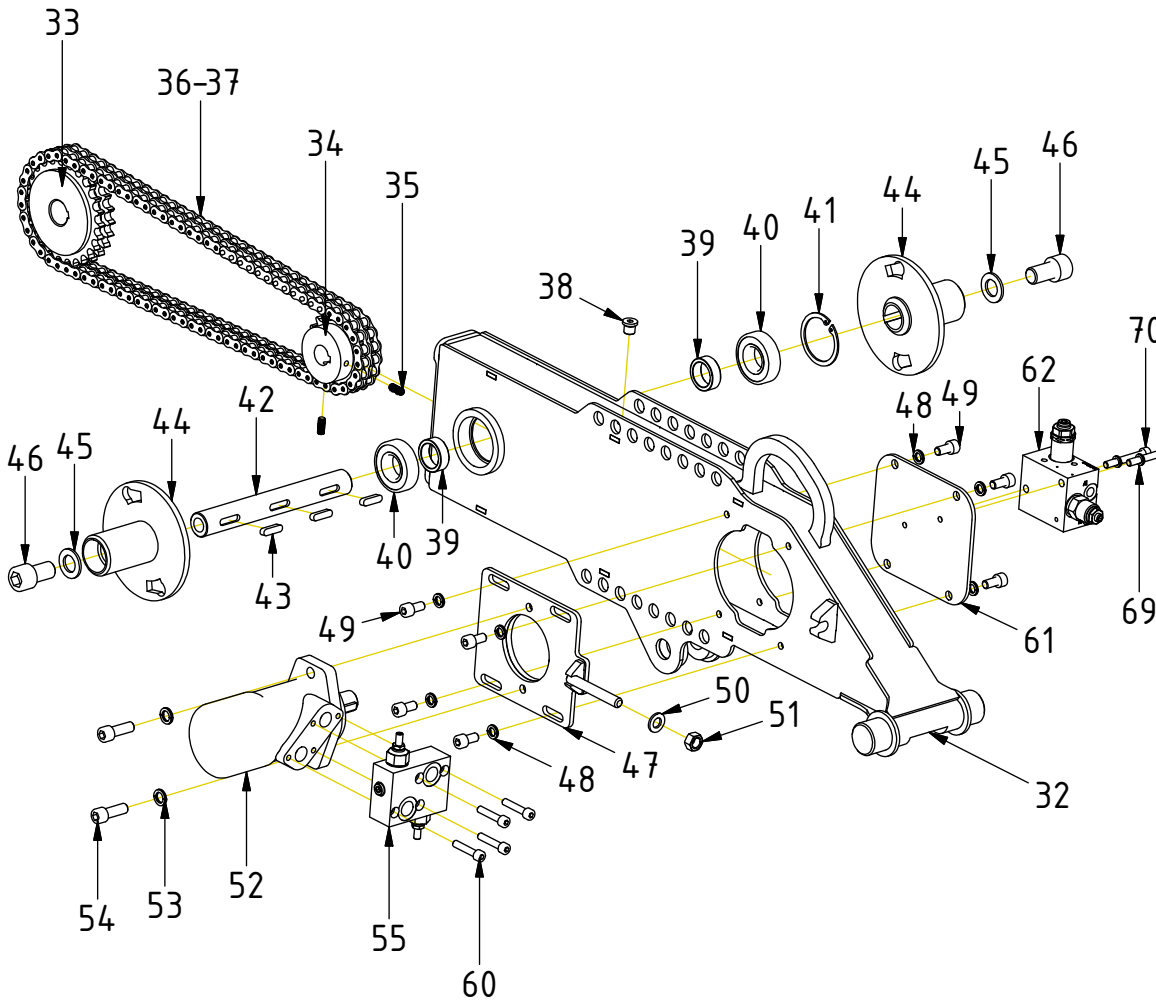

POS	DESCRIPTION	PART	QTY	COMMENTS
32	Sweep arm SWD40	1069235	1	
33	Chainwheel 30H7+K+S D-58-25	1058172	1	
34	Chainwheel 25H7+K+S D-58-17	1034588	1	
35	Screw SK6SS 8x20	6000190	2	
36	Chain Tsubaki RS10B-2 1,286m 81link	1069925	1	
37	Coupling link RS10B-2	1047913	1	
38	Plug Din 908 1/4"	711505	1	
39	Spacer ring 40/31 L13,5	1069682	2	
40	Bearing 6206-2RS	1033934	2	
41	Circlip SqH 62	640219	1	
42	Axle Ø30 SWD40	1067682	1	
43	Feather Key 8x7x30	6000188	3	
44	Sweep carrier SWD40	1067679	2	
45	Washer NL20sp 21,4x39,0x3,4	6000338	2	
46	Screw MC6S M20x35 12.9	6000205	2	
47	Motor mounting plate	1035581	1	
48	Washer NL 10mm	611041	12	
49	Screw MC6S M10x20 12.9	610451	8	
50	Washer BRB 13x24x2,5 200 HV FZB	611007	1	
51	Nut M6M M12 8	610907	1	
52	Hydraulic motor MP160CDP	7001799	1	
53	Washer NL 12mm	611042	14	
54	Screw MC6S M12x35 12.9 ZFSHL	6000150	2	
55	Crossover valve (160 bar) KPDR80	7000695	1	
60	Screw MC6S M8x40 12.9 ZFSHL	6000145	4	
61	Plate	1036784	1	
62	Block hydraulic valve SWD	7000700	1	
69	Washer NL 8mm	611040	12	QTY: 10 part of brush holders
70	Screw MC6S M8x60 12.9	610441	2	

POS in order of assembly

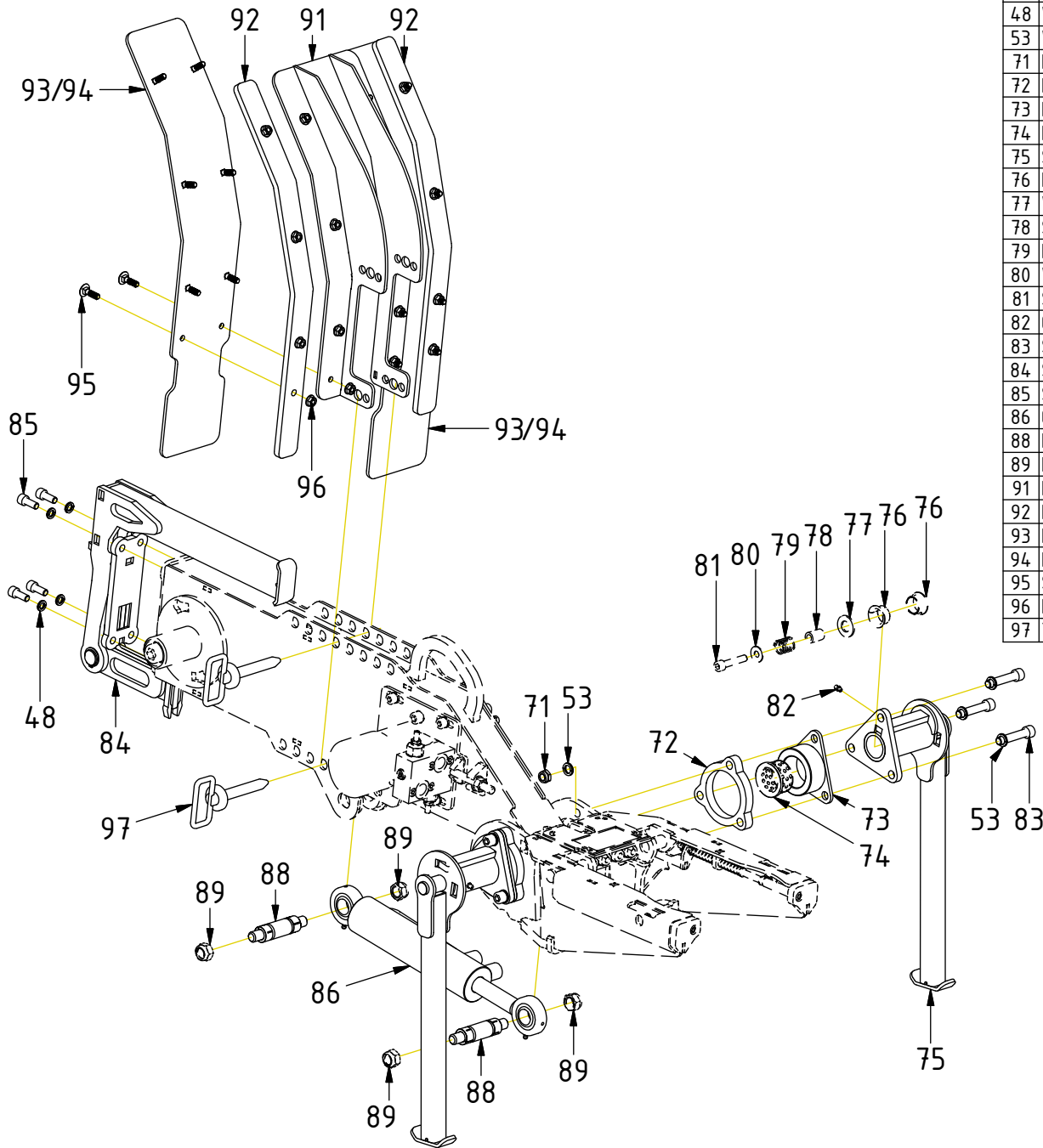

POS	DESCRIPTION	PART	QTY	COMMENTS
48	Washer NL 10mm	611041	12	
53	Washer NL 12mm	611042	14	
71	Lock Nut M6M M12x1,75 8,8 FZB	610924	6	
72	Distanse Plate SWD40	1067695	2	
73	Bushing holder SWD	1041270	2	(POS.74 incl.)
74	Bushing BWG-F 40/50/55/5x30	631001	2	
75	Support legs (2) SWD cassette	1044412	1	(POS.76-82 incl.)
76	Bushing WB802 25/28/35x16 WF	630001	4	
77	Washer Ø34/17,5 t=3	1041264	2	
78	Spacer sleeve Ø17/10,2 L25	1041265	2	
79	Pressure spring SF-TF 1566	1041257	2	
80	Washer SRKB FZB 10,5x25x1,5	6000300	2	
81	Screw MC6S M10x50 12.9	610457	2	Loxeal 83-52
82	Grease Nipple	711405	2	
83	Screw MC6S M12x60 12.9 ZFSHL	6000140	6	
84	Support leg SWD arm	1043000	1	
85	Screw MC6S M10x25 12.9 ZFSHL	6000195	4	
86	Cylinder SWD	1038793	1	
88	Expansion axle	1067625	2	(POS.89 incl.)
89	Hex. Nut M16 Nylon Lock	610926	4	Torque: 175Nm
91	Protection plate SWD40/45/60	1037932	1	
92	Edge support plate	1038230	2	
93	Protection BK340	1067721	2	
94	Protection BK1200	1069247	1	
95	Screw MVBF 8x30	6000177	16	
96	M6MF M8 Lock	6000211	16	
97	Towing sprit	1038003	2	

POS in order of assembly

POS in order of assembly

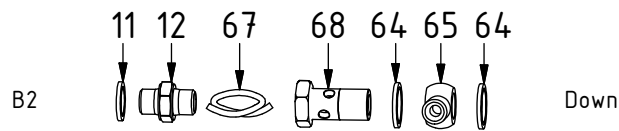
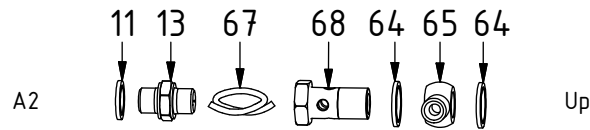
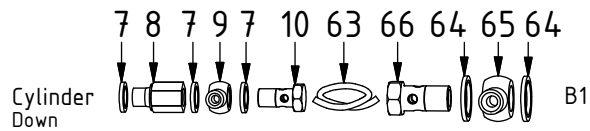
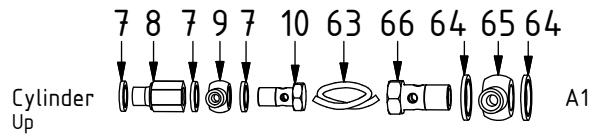
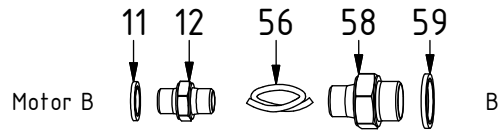
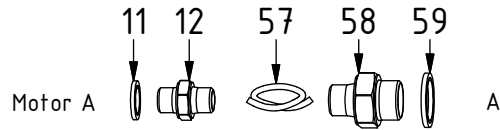

POS	DESCRIPTION	PART	QTY	COMMENTS
7	Washer GBR02 1/8	710701	6	
8	Adapter 236-02-02	710129	2	
9	Adapter 830-02-02 (1/8")	712212	2	
10	Banjo bolt 4451-02 (1/2")	710277	2	
11	Washer GBR04 1/4	710702	4	
12	Adapter 138-04-29 (1/4")	710135	3	
13	Adapter 139-00-02 (1/4)	7000713	1	
56	Hose Motor Short	7001814	1	
57	Hose Motor Long	7001813	1	
58	Adapter 135-06-08	710122	2	
59	Washer GBR08 1/2	710704	2	
63	Hose Hyd.Bl.	7001816	2	
64	Washer GBR06 3/8	710703	8	
65	Adapter 830-04-04 (1/4")	710145	4	
66	Banjo bolt 4451-04 (1/4")	710271	2	
67	Hose Cylinder	7001815	2	
68	Banjo bolt 4451-06 (3/8")	710272	2	
87	Hose kit SWD40	7001812	1	(POS.56-57, 63, 67 incl.)

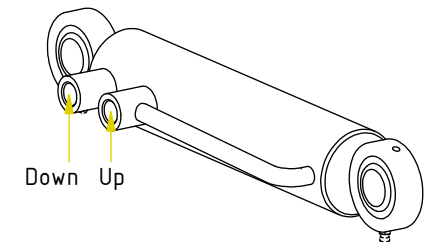
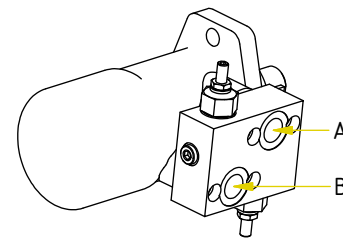
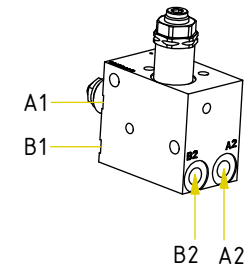
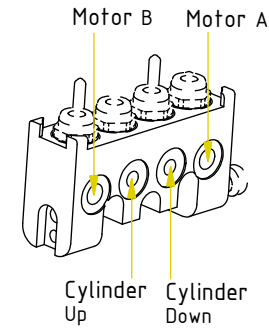

POS	DESCRIPTION	PART	QTY	COMMENTS
29	Lock Nut M6M M8x1,25 8,8 FZB	610922	10	QTY: 6 part of brush holders
69	Washer NL 8mm	611040	12	QTY: 10 part of brush holders
98	Brush Cassette-SWD-340 Ø600 x2	1069731	1	
99	Brush Cassette-SWD-1200 Ø700 x2	1069987	1	
100	Frame Brush Holder SWD 340	1067666	1	
101	Frame Brush Holder SWD 1200	1067672	1	
102	Brush segment D=600 d=180	1033883	6	
103	Brush segment D=700 d=254	1047895	12	
104	Lock pin SWD4.0	1067689	2	
105	Pressure spring TF 1464	1034596	2	
106	Handle plate - SWD	1036790	1	
107	Handle plate large - SWD	1035594	1	
108	Cover plate Brushes Ø180	1034601	1	
109	Cover plate Brushes Ø250	1034746	1	
110	Screw MC6S 8x25 12.9 ZFSHL	6000143	4	

POS in order of assembly

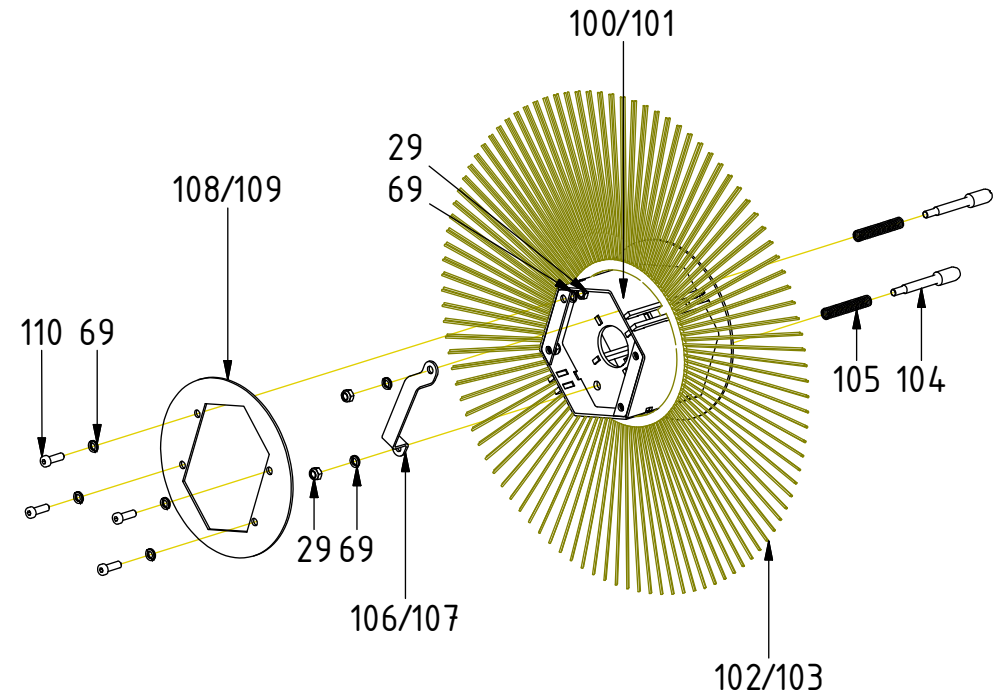
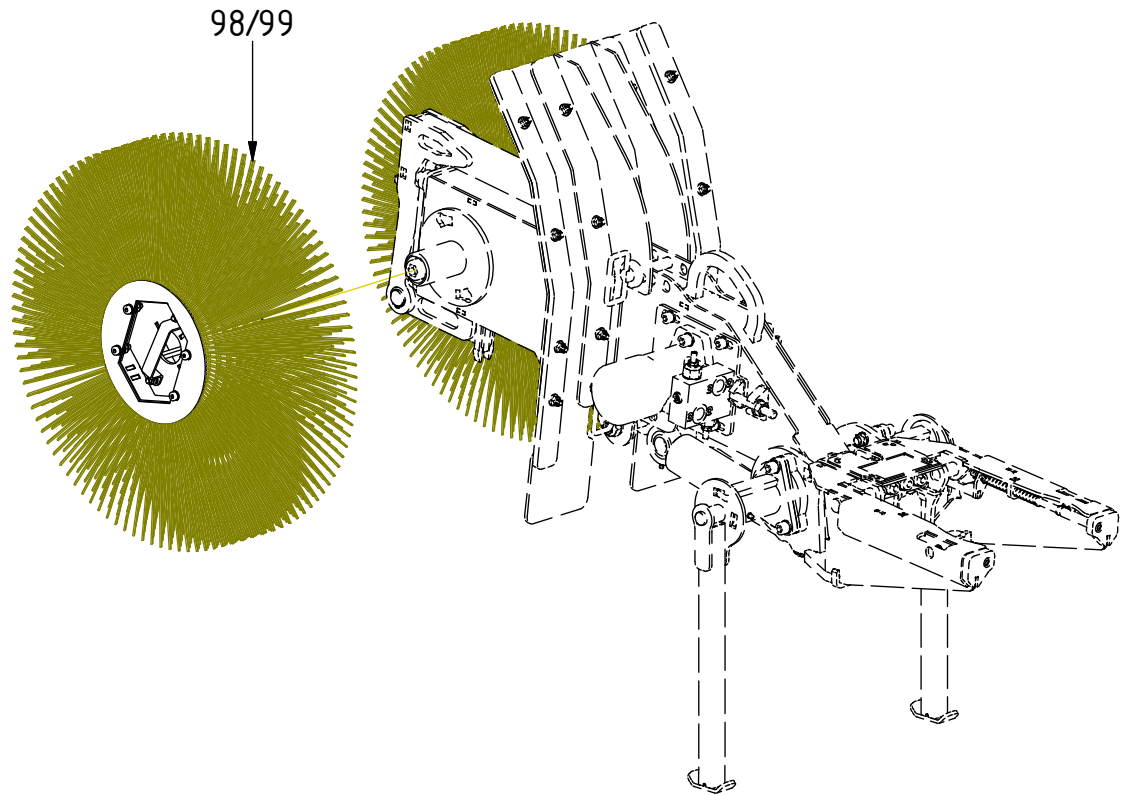

NB! The 2 furthest segments on each side mounts in same direction.

POS	DESCRIPTION	PART	QTY	COMMENTS
19	With Q-block retracted, grooves on eccenter must be facing Q-block			
56	Hose Motor Short	7001814	1	
57	Hose Motor Long	7001813	1	
63	Hose Hyd.Bl.	7001816	2	
67	Hose Cylinder	7001815	2	

POS in order of assembly

Photo needed: Hoses to Q-block

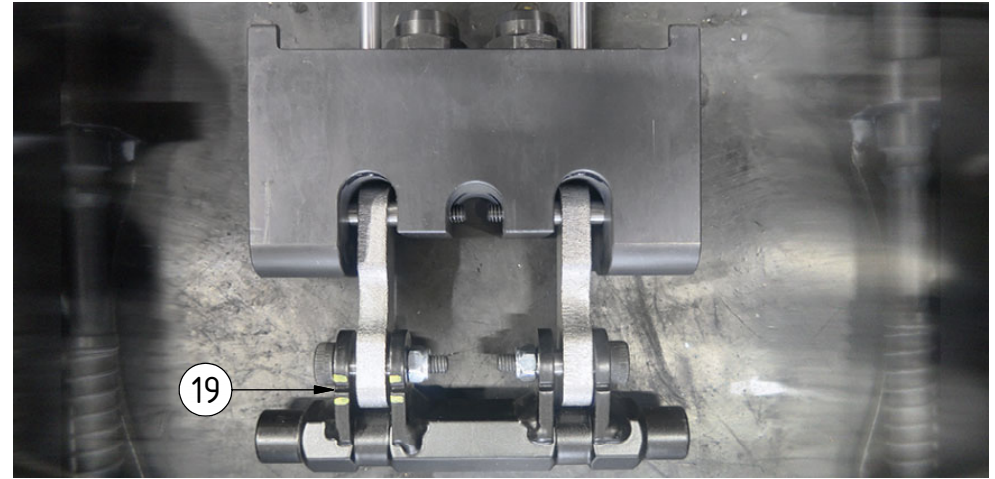

Photo needed: Seen from the left (Hoses between Q-block & motor)

Photo needed: Seen from the right (Hoses between Q-block & hyd.block, between hyd.block & cylinder)