

COVERSHEET

Planned document changes:

Briefly:

No planned changes.

Document changes:

Date:	Change:	Rev. after change:
2024-08-19	Valves for EC214 updated.	G
2024-02-22	ePS1 moved to spare parts, ePS2 reference added.	F
2021-09-23	EC209 removed.	E
2021-04-26	Jumper for ss9SQ added.	D
2021-02-10	Photos updated.	C
2020-12-11	Missing torques added.	B
2020-11-11	EC209 added.	A
2020-08-28	New document.	-

Readers note:

 Indicates instruction.

 Represents Hose.

Dashed lines for overview, mounts
on other pages/assemblies.

EC214, EC219, EC226, EC233

POS	DESCRIPTION	PART	QTY	COMMENTS
1	O-ring 7,65x1,78	710960	4	
2	Directional valve NG4 IQS 12V DT	1042045	1	(POS.1, 4, 6 incl.)
3	Directional valve NG4 IQS 24V DT	1042188	1	(POS.1, 5, 6 incl.)
4	Coil IQS 12V DT	1042065	1	
5	Coil IQS 24V DT	1042066	1	
6	Nut 1270-04	710250	1	
7	O-ring 9,25x1,78	710901	8	
8	Directional valve closed 24V	730110	2	EC219-233 (POS.7, 11, 12 incl.)
9	O-ring square 12,42x1,68	750704	5	
10	Directional valve closed NG10 24V	730341	1	(POS.9, 11, 12 incl.)
11	Coil 24V JT	730118	3	QTY: 1 for EC214
12	Nut directional valve	730135	3	QTY: 1 for EC214
13	O-ring 8,75x1,78	710959	8	
14	Directional valve closed 24V	7001618	2	EC214 (POS.13, 18, 20 incl.)
15	Directional valve closed 12V	7001619	2	EC214 (POS.13, 19, 20 incl.)
16	Directional valve closed NG10 12V	730342	1	EC214 (POS.9, 17, 12 incl.)
17	Coil 12V JT	730117	1	
18	Coil NG6 24V JT ATOS	7001736	2	
19	Coil NG6 12V JT ATOS	7001735	2	
20	Nut directional valve ATOS	7001887	2	
21	Screw MC6S M5x50 12.9	610407	3	Torque: 9,7Nm
22	Screw MC6S M5x30 12.9	610403	8	Torque: 9,7Nm
23	Screw MC6S M6x40 12.9	610418	4	Torque: 17Nm
24	Adapter cabel-Hirschmann-Amp	302971	1	

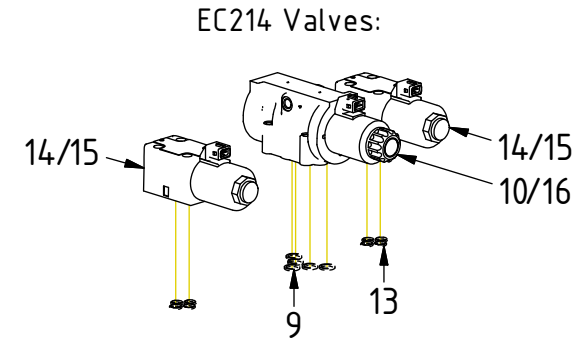
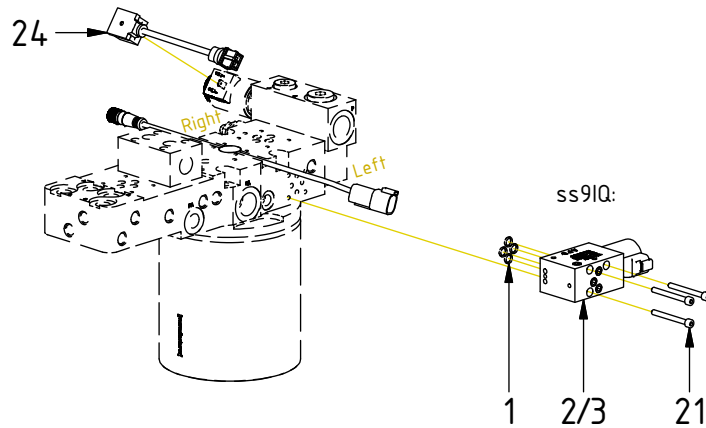
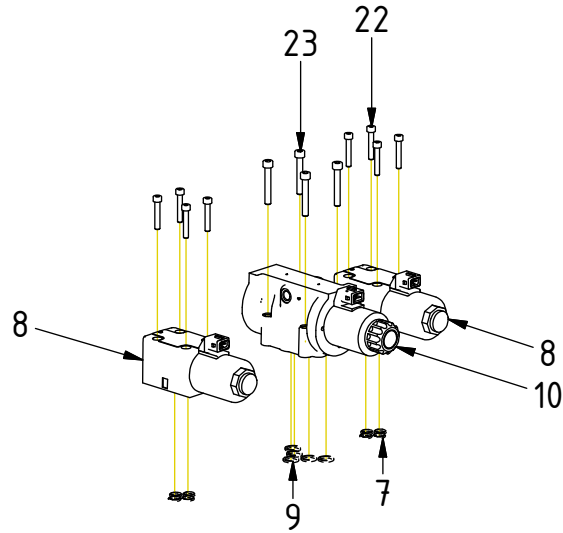

POS in order of assembly

Cables

EC214, EC219, EC226, EC233

POS	DESCRIPTION	PART	QTY	COMMENTS
25	Q-Safe connector			
26	Aggregate cable ss9-2 DT Complete	8001823	1	
27	ILME cover	810208	1	(Incl. with agq.cable)
28	Cable QS QLM tiltrotator ss9-2	842148	1	
29	DT Jumper SQ/QSC ss9-2	1034439	1	Plug DT connector for ss9SQ
30	Protection plate End lock EC209-219	1063372	1	
31	Protection plate End lock EC226	1063521	1	
32	Protection plate End lock EC233	1064168	1	
33	Screw MC6S M12x70 12.9 ZFSHL	611517	8	For EC214. Torque: 136Nm
34	Screw MC6S 12x90 12.9 ZFSHL	6000147	8	For EC219. Torque: 136Nm
35	Screw MC6S 14x80 12.9 ZFSHL	6000354	8	For EC226. Torque: 217Nm
36	Screw MC6S M12x80 12.9 ZFSHL	6000148	12	For EC233. Torque: 136Nm
37	Adapter cable ECO (DTM) ss9-2	1029599	1	For EC-Oil. Instead of POS.26 & 28

POS in order of assembly

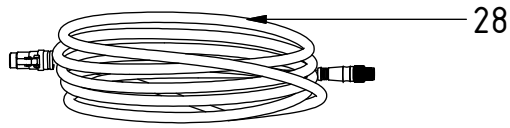

28

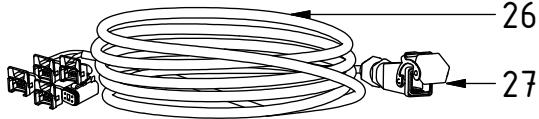

26

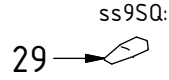

29

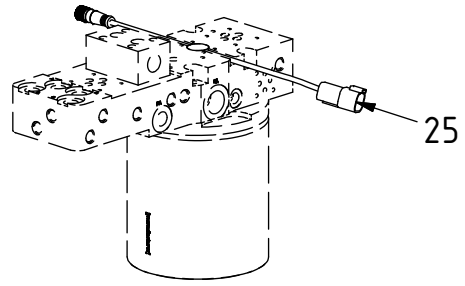

25

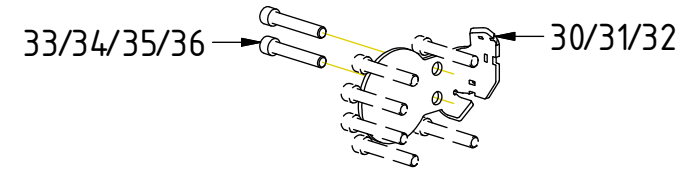

33/34/35/36

30/31/32

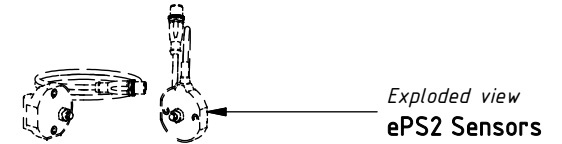

Exploded view
ePS2 Sensors

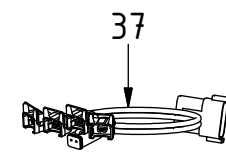

37

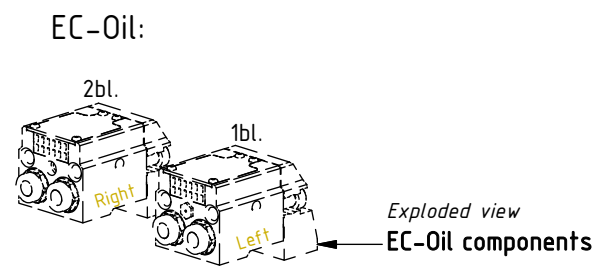

EC-Oil:

2bl.

1bl.

Right

Left

Exploded view
EC-Oil components

Cables

EC214, EC219, EC226, EC233

Without EC-Oil

POS	DESCRIPTION	PART	QTY	COMMENTS
25	Q-Safe connector			
26	Aggregate cable ss9-2 DT Complete	8001823	1	
28	Cable QS QLM tiltrotator ss9-2	842148	1	
●	Use cable ties			

POS in order of assembly

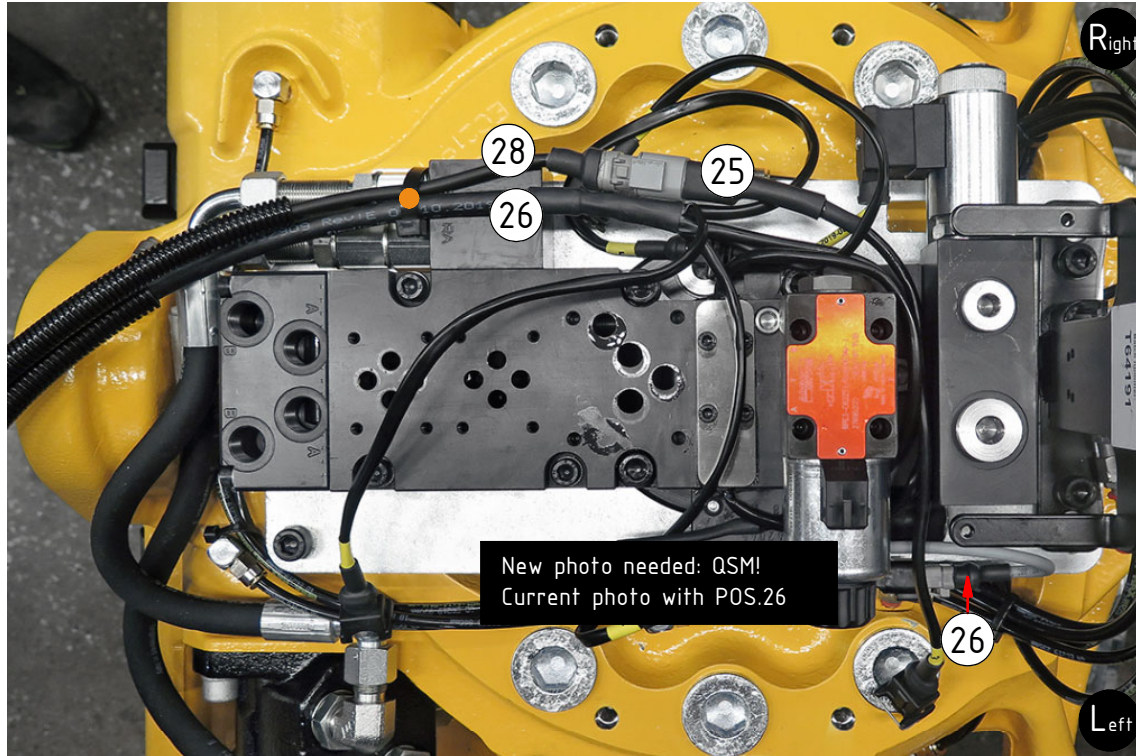

New photo needed: QSM!
Current photo with POS.26

Cables Left (std)

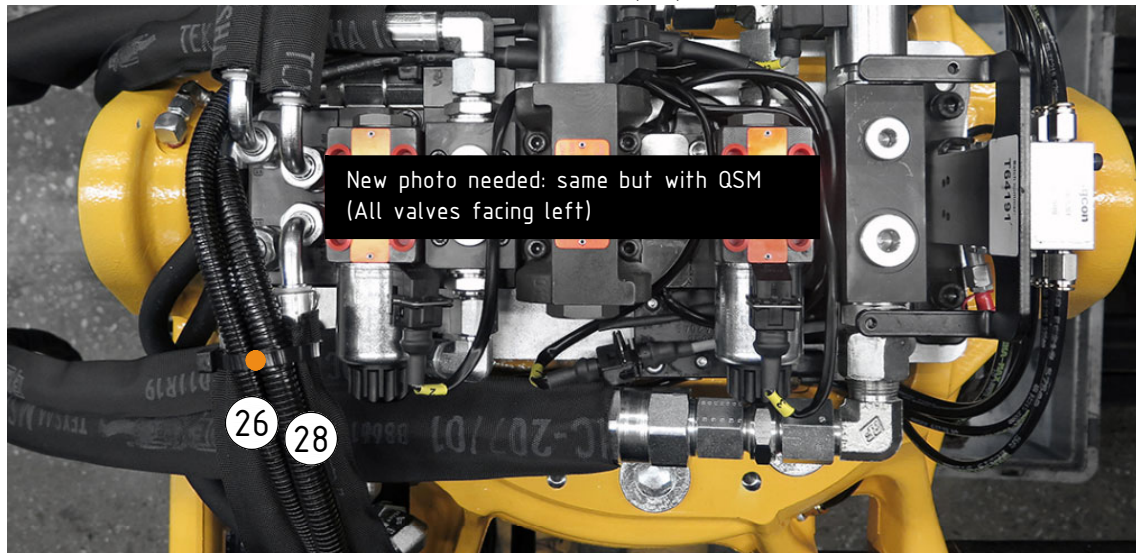

New photo needed: same but with QSM
(All valves facing left)

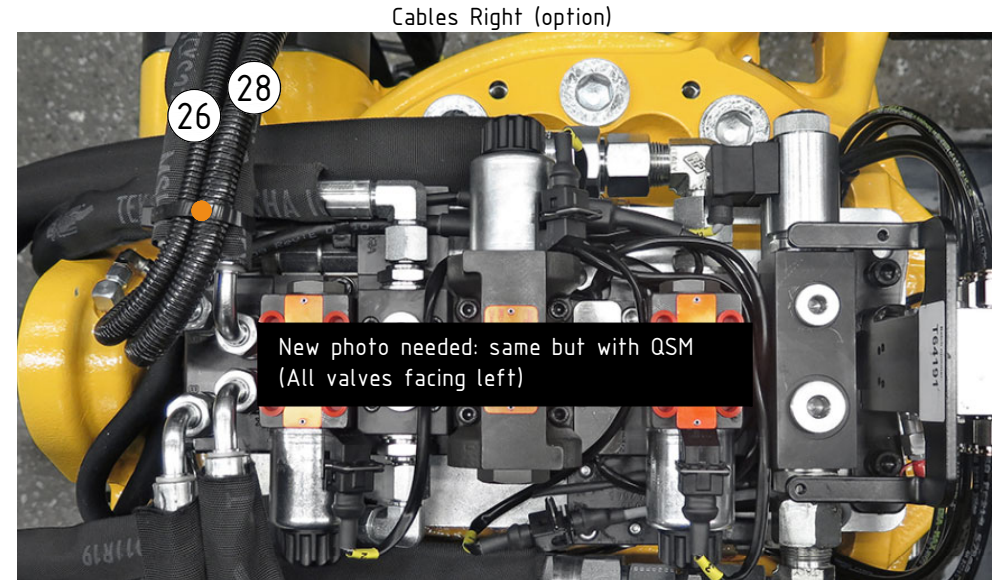

New photo needed: same but with QSM
(All valves facing left)

Cables Right (option)

Cables
EC-Oil

EC214, EC219, EC226, EC233

POS	DESCRIPTION	PART	QTY	COMMENTS
25	Q-Safe connector			
37	Adapter cable ECO (DTM) ss9-2	1029599	1	For EC-Oil. Instead of POS.26 & 28

POS in order of assembly

New photo needed: POS.25 to 6P from block, POS.37 to 12P from block

Lubrication

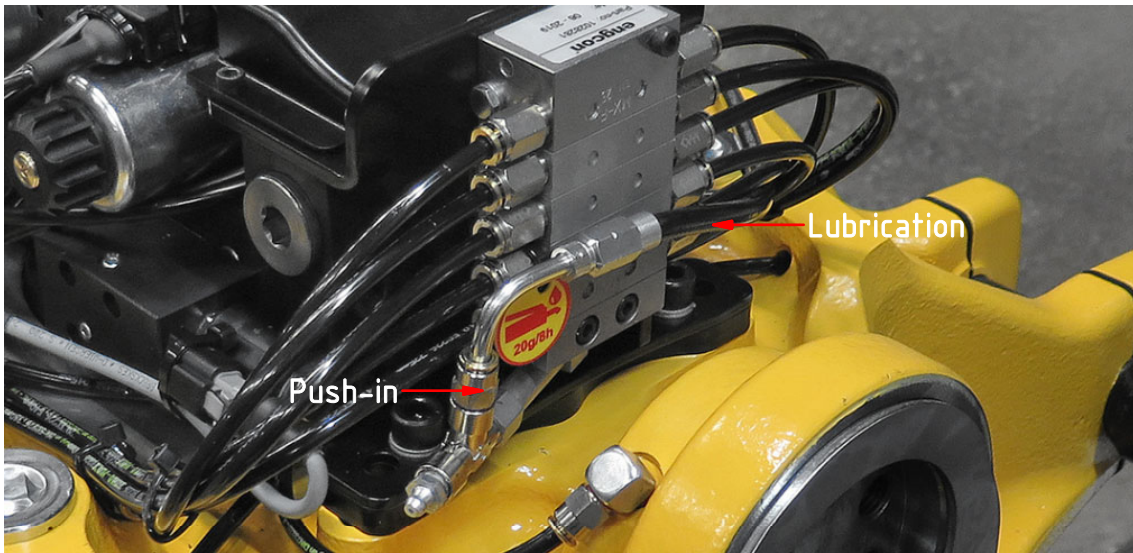

Valves

EC214, EC219, EC226, EC233

POS	DESCRIPTION	PART	QTY	COMMENTS
24	Adapter cabel-Hirschmann-Amp	302971	1	
29	DT Jumper SQ/QSC ss9-2	1034439	1	Plug DT connector for ss9SQ
	● Use cable ties			

POS in order of assembly

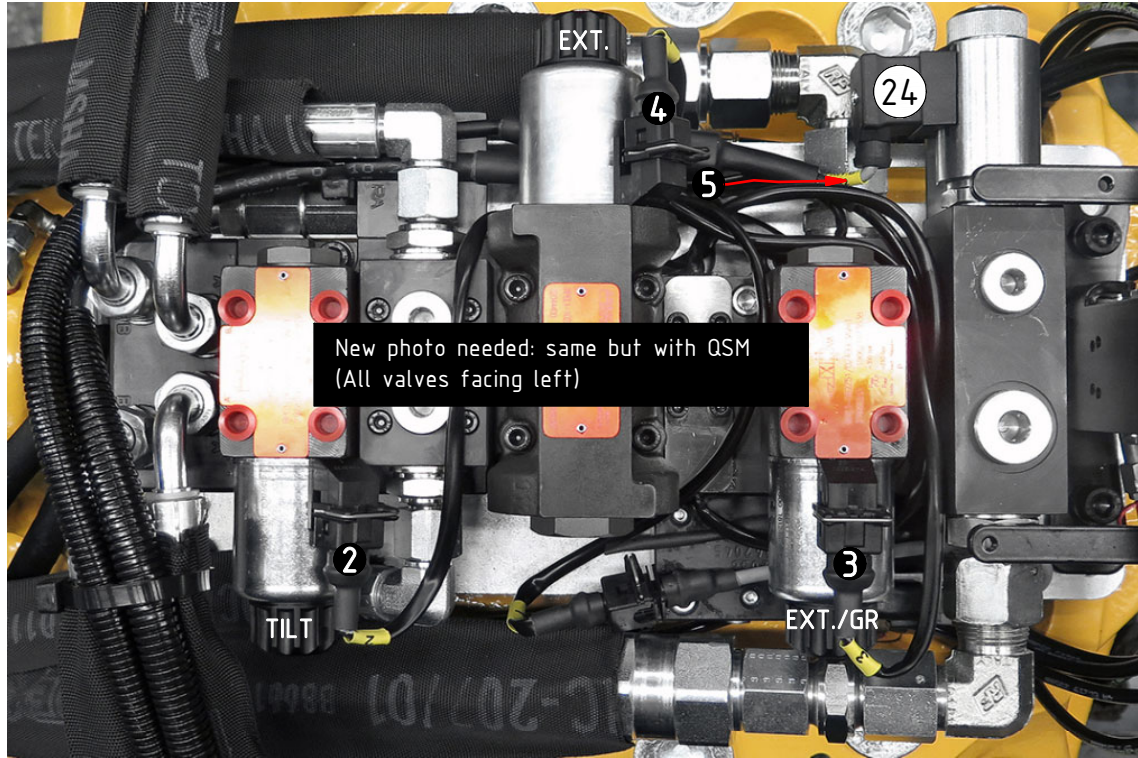

ss9IQ:



SPARE PARTS

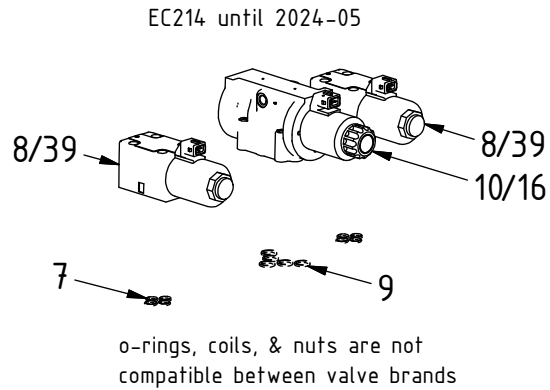

POS	DESCRIPTION	PART	QTY	COMMENTS
7	O-ring 9,25x1,78	710901	8	
8	Directional valve closed 24V	730110	2	EC219-233 (POS.7, 11, 12 incl.)
9	O-ring square 12,42x1,68	750704	5	
10	Directional valve closed NG10 24V	730341	1	(POS.9, 11, 12 incl.)
11	Coil 24V JT	730118	3	
12	Nut directional valve	730135	3	
16	Directional valve closed NG10 12V	730342	1	EC214 (POS.9, 17, 12 incl.)
17	Coil 12V JT	730117	1	
26	Aggregate cable ss9-2 DT Complete	8001823	1	
27	ILME cover	810208	1	(Incl. with agg.cable)
29	DT Jumper SQ/QSC ss9-2	1034439	1	Plug DT connector for ss9SQ
39	Directional valve closed 12V	730112	2	(POS.7, 17, 12 incl.)
40	Aggregate cable ss9-2 Dump Comp.	1032909	1	Replaced by POS.26 from 2022-06
41	Adapter cable DT-JT	1017478	1	Used with POS.40 for ss9IQ
42	JT Jumper Lock valve	1018662	1	Used with POS.40 for ss9SQ
43	Valve spacer	1034402	5	
44	Rubber steel clamp \varnothing 16	6000009	1	
45	Screw K6S M5x16 10.9 FZB	611818	1	Torque: 8,1Nm
46	Bracket ePS1	1038119	1	For Topcon/LEICA/Novatron
47	Bracket ePS1 (Trimble only)	1038117	1	For Trimble
48	Screw MC6S M5x16 12.9	610401	4	Torque: 9,7Nm
49	Unit cable ePS w. 120 ohm termin.	8000824	1	
50	Adapter cable ePS rotation sensor	8000784	1	
51	Ad.cable ePS ECOW w. 120 ohm ter.	8000825	1	For ECO w. ePS. Instead of POS.49
52	Protection EC214PS-EC219PS	1033565	1	
53	Protection EC233PS	1040940	1	
54	Protection EC226PS V2	1055677	1	

ePS1:

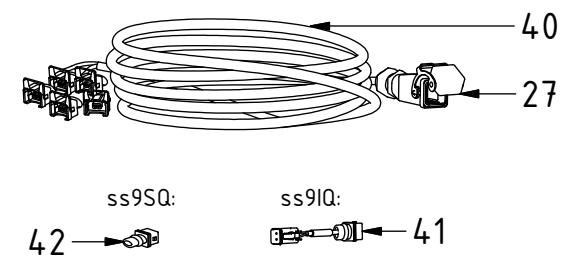
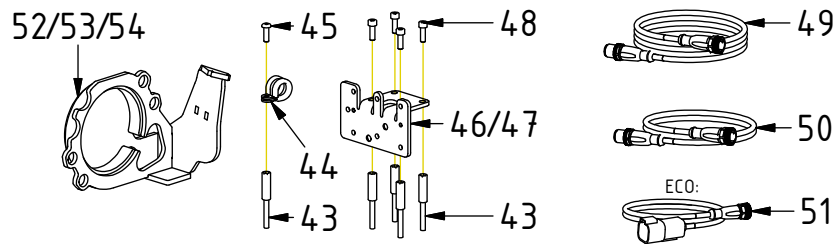

POS in order of assembly