

COVERSHEET

Planned document changes:

Briefly:

 No planned changes.

Document changes:

Date:	Change:	Rev. after change:
2024-08-16	Spare part cable for ePS1 updated.	L
2024-05-22	Valves for EC214 updated.	K
2023-10-03	ePS1 moved to spare parts, ePS2 reference added.	J
2021-11-02	EC-Oil photos updated.	I
2021-06-10	DC2 updated, QSC connected as standard. EC-Oil details for lock valve added.	H
2021-03-04	Layout/irrelevant.	G
2021-01-26	EC209 removed.	F
2020-11-27	Option PROP on grab/extra added.	E
2020-11-02	Photos replaced.	D
2020-08-20	EC226 ePS protection replaced.	C
2020-03-13	EC209 added.	B
2020-02-25	ePS cables replaced. Photos replaced. Spare parts added.	A
2019-08-14	New document.	-

Readers note:
 Indicates instruction.

 Represents Hose.

Dashed lines for overview, mounts
on other pages/assemblies.

EC214, EC219, EC226, EC233

EC219-EC233:

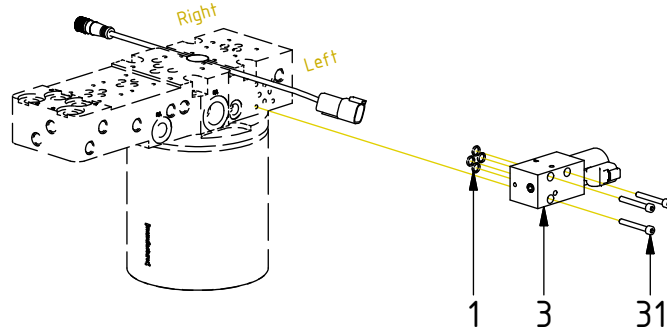
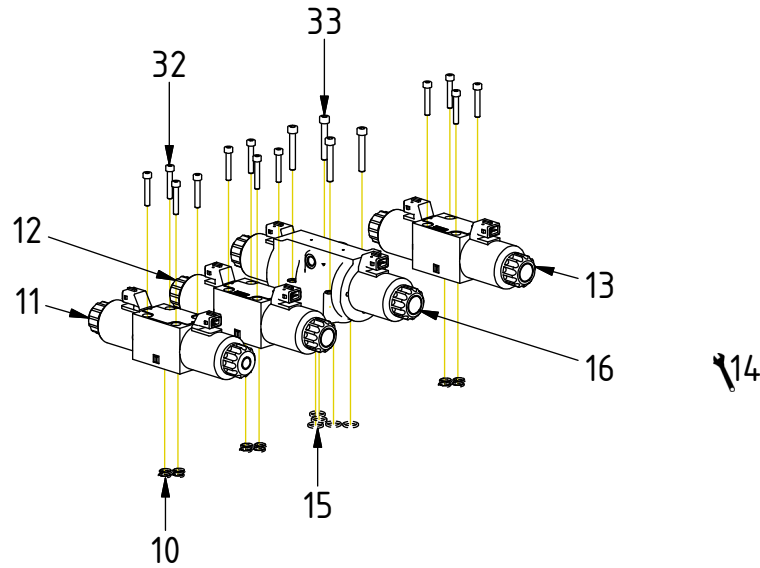

EC-Oil:

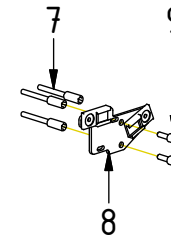

POS	DESCRIPTION	PART	QTY	COMMENTS
1	O-ring 7,65x1,78	710960	4	
3	Directional valve NG4 IQS 24V DT	1042190	1	(POS.1, 5, 6 incl.)
5	Coil IQS 24V DT	1042066	1	
6	Nut 1270-04	710250	1	
7	Valve spacer M5x39	1047243	3	Torque: 9,7Nm
8	Mounting plate-2x Deutsch NG4	1059664	1	
9	Screw MC6S M5x16 12.9	610401	2	Torque: 9,7Nm
10	O-ring 9,25x1,78	710901	12	
11	Directional valve prop 12V open T	7000092	1	EC219-233 (POS.10, 17, 19 incl.)
12	Directional valve prop 12V	730190	1	EC219-233 (POS.10, 17, 19 incl.)
13	Directional valve NG6 24V	730103	1	EC219-233 (POS.10, 18, 19 incl.)
14	For option PROP on grab/extra			See p.11 for instruction
15	O-ring square 12,42x1,68	750704	5	
16	Directional valve NG10 24V	730339	1	(POS.15, 18, 19 incl.)
17	Coil 12V prop JT	730192	4	
18	Coil 24V JT	730118	4	QTY: 2 for EC214
19	Nut directional valve	730135	8	QTY: 2 for EC214
31	Screw MC6S M5x40 12.9	610405	3	Torque: 9,7Nm
32	Screw MC6S M5x30 12.9	610403	12	Torque: 9,7Nm
33	Screw MC6S M6x40 12.9	610418	4	Torque: 17Nm

POS in order of assembly

Std. Valves & cables - ss10 (DC2/SVAB) QSM

EC214, EC219, EC226, EC233

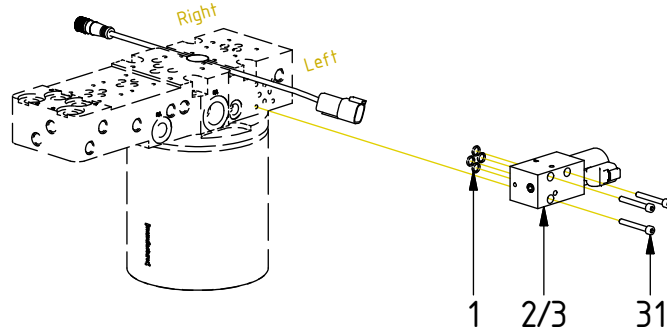
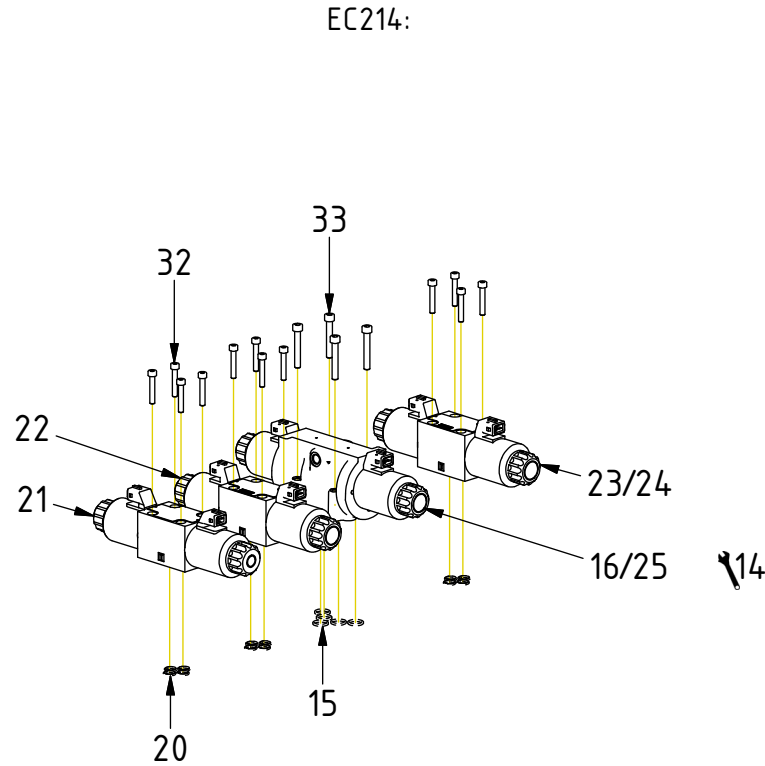

EC-Oil:

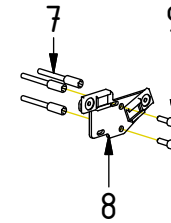

POS	DESCRIPTION	PART	QTY	COMMENTS
1	O-ring 7,65x1,78	710960	4	
2	Directional valve NG4 IQS 12V DT	1042047	1	(POS.1, 4, 6 incl.)
3	Directional valve NG4 IQS 24V DT	1042190	1	(POS.1, 5, 6 incl.)
4	Coil IQS 12V DT	1042065	1	
5	Coil IQS 24V DT	1042066	1	
6	Nut 1270-04	710250	1	
7	Valve spacer M5x39	1047243	3	Torque: 9,7Nm
8	Mounting plate-2x Deutsch NG4	1059664	1	
9	Screw MC6S M5x16 12.9	610401	2	Torque: 9,7Nm
14	For option PROP on grab/extra			See p.11 for instruction
15	O-ring square 12,42x1,68	750704	5	
16	Directional valve NG10 24V	730339	1	(POS.15, 18, 19 incl.)
18	Coil 24V JT	730118	4	QTY: 2 for EC214
19	Nut directional valve	730135	8	QTY: 2 for EC214
20	O-ring 8,75x1,78	710959	12	
21	Directional valve prop 12V open T	7001615	1	EC214 (POS.20, 27, 30 incl.)
22	Directional valve prop 12V	7001614	1	EC214 (POS.20, 27, 30 incl.)
23	Directional valve NG6 24V	7001616	1	EC214 (POS.20, 28, 30 incl.)
24	Directional valve NG6 12V	7001617	1	EC214 (POS.20, 29, 30 incl.)
25	Directional valve NG10 12V	730340	1	EC214 (POS.15, 26, 19 incl.)
26	Coil 12V JT	730117	2	
27	Coil NG6 12V prop JT ATOS	7001734	4	
28	Coil NG6 24V JT ATOS	7001736	2	
29	Coil NG6 12V JT ATOS	7001735	2	
30	Nut directional valve ATOS	7001887	6	
31	Screw MC6S M5x40 12.9	610405	3	Torque: 9,7Nm
32	Screw MC6S M5x30 12.9	610403	12	Torque: 9,7Nm
33	Screw MC6S M6x40 12.9	610418	4	Torque: 17Nm

POS in order of assembly

Std. Valves & cables - ss10 (DC2/SVAB) QSM

Cables
DC2

EC214, EC219, EC226, EC233

POS	DESCRIPTION	PART	QTY	COMMENTS
34	Q-Safe connector			
35	Tiltrotator module DC2 Q-Safe	842137	1	
36	JT Jumper QSC connected	1018662	1	Plug JT connector "1"
37	EC219: module turned 90° Cables assy. remains the same			
38	Screw MC6S M5x12 12.9	6000077	2	
39	Aggregate cable DC2 Compl. QSC DT	8001201	1	
40	ILME cover	810208	1	(Incl. with agg.cable)
41	Adapter cable ECOW DC2 DTM 2xM12	8001847	1	For EC-Oil. Instead of agg.cable
43	Protection plate End lock EC209-219	1063372	1	
44	Protection plate End lock EC226	1063521	1	
45	Protection plate End lock EC233	1064168	1	
46	Screw MC6S M12x70 12.9 Geomet	611517	8	For EC214. Torque: 136Nm
47	Screw MC6S 12x90 12.9 ZFSHL	6000147	8	For EC219. Torque: 136Nm
48	Screw MC6S 14x80 12.9 ZFSHL	6000354	8	For EC226. Torque: 217Nm
49	Screw MC6S M12x80 12.9 ZFSHL	6000148	12	For EC233. Torque: 136Nm

POS in order of assembly

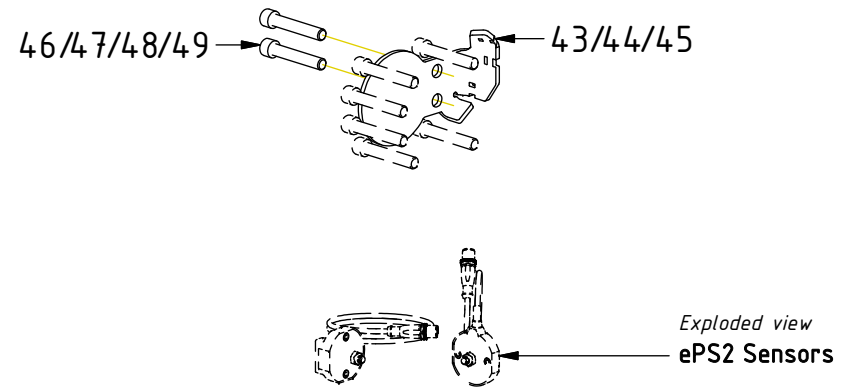
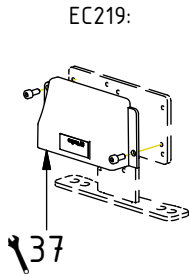
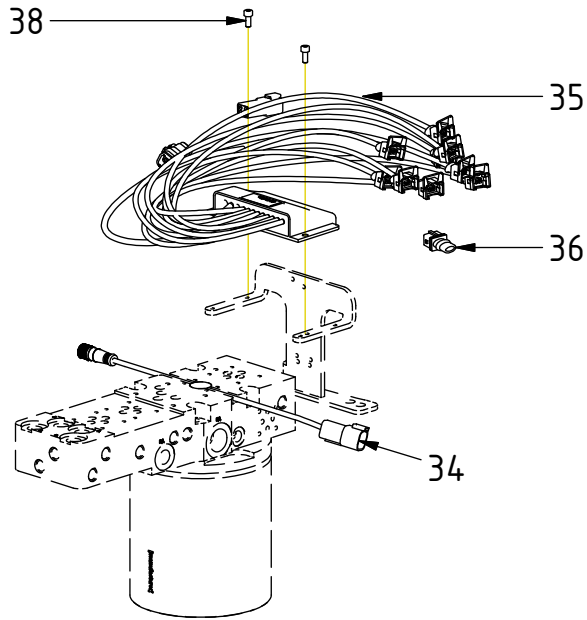
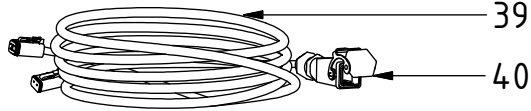

Exploded view
ePS2 Sensors

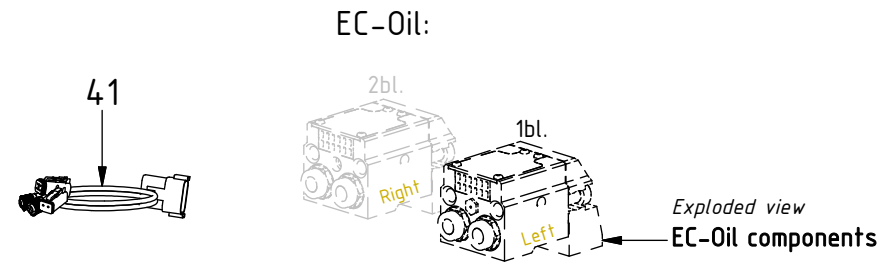

Exploded view
EC-Oil components

Std. Valves & cables - ss10 (DC2/SVAB) QSM

Cables ss10 (SVAB)

EC214, EC219, EC226, EC233

POS	DESCRIPTION	PART	QTY	COMMENTS
34	Q-Safe connector			
43	Protection plate End lock EC209-219	1063372	1	
44	Protection plate End lock EC226	1063521	1	
45	Protection plate End lock EC233	1064168	1	
46	Screw MC6S M12x70 12.9 Geomet	611517	8	For EC214. Torque: 136Nm
47	Screw MC6S 12x90 12.9 ZFSL	6000147	8	For EC219. Torque: 136Nm
48	Screw MC6S 14x80 12.9 ZFSL	6000354	8	For EC226. Torque: 217Nm
49	Screw MC6S M12x80 12.9 ZFSL	6000148	12	For EC233. Torque: 136Nm
50	Adapter cable JT>DT (Lock valve)	1017478	1	(Previously also for DC2)
51	Aggregate cable SVAB Complete	1015196	1	
52	ILME cover 16P contact with jumper	810235	1	(Incl. with agq.cable)
53	Cable QS QLM tiltrotator SVAB	842148	1	
54	Adapter cable ECO (DTM) SVAB	1029599	2	For EC-Oil. Instead of POS.50-53

POS in order of assembly

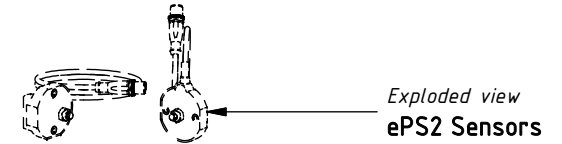
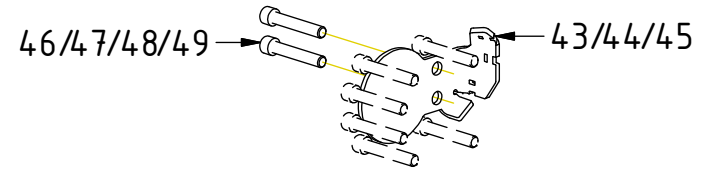
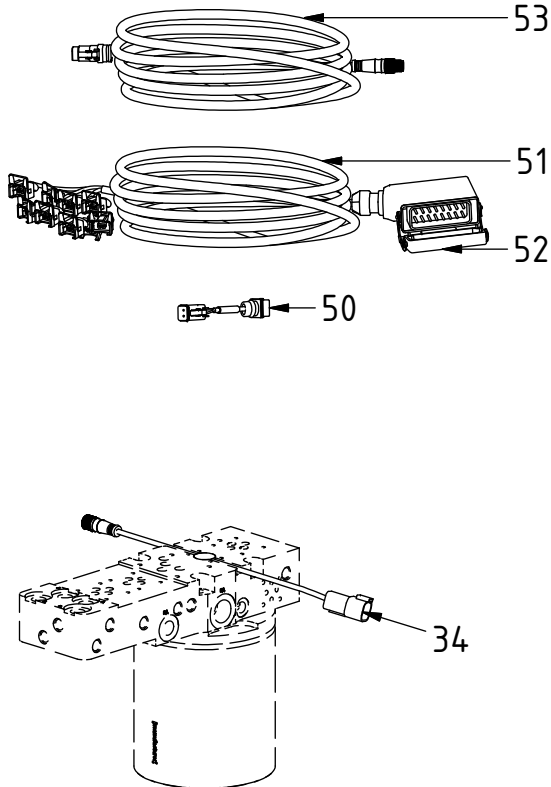

EC-Oil:

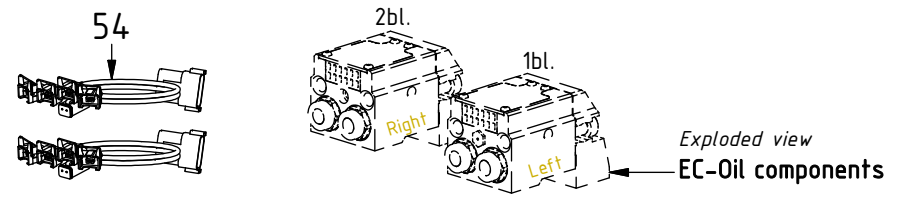

Std. Valves & cables - ss10 (DC2/SVAB) QSM

Cables

DC2 without EC-Oil

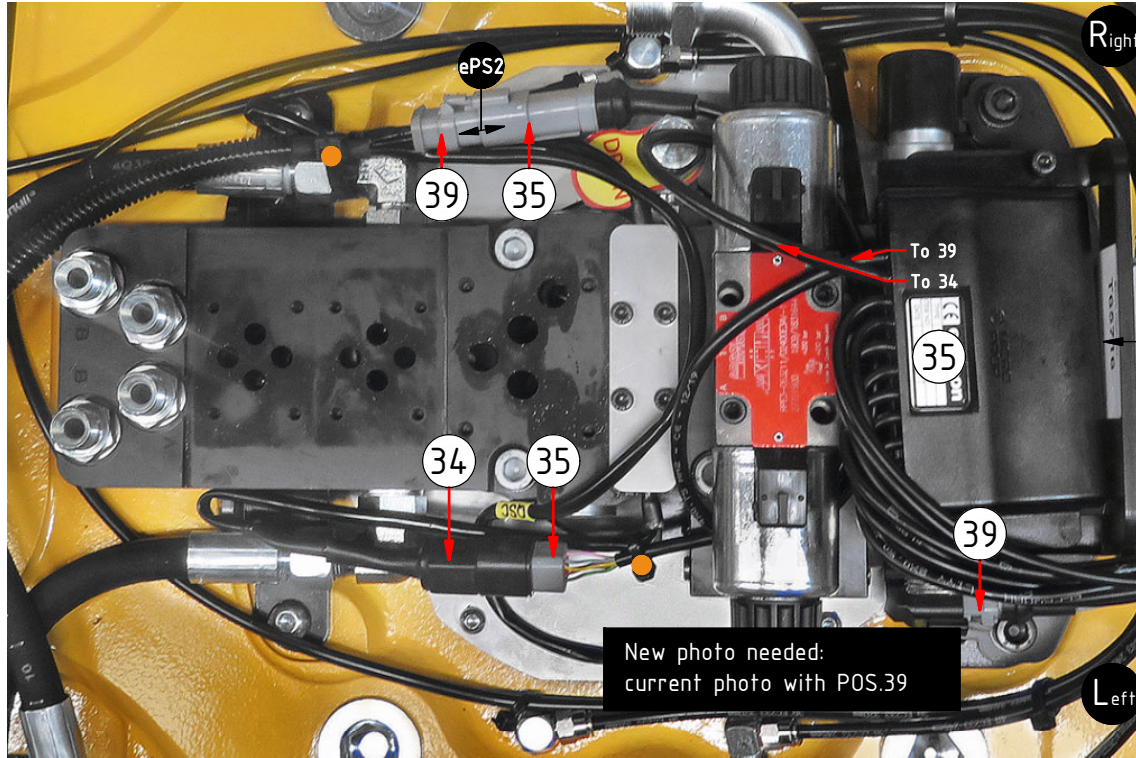

Cables Left (std)

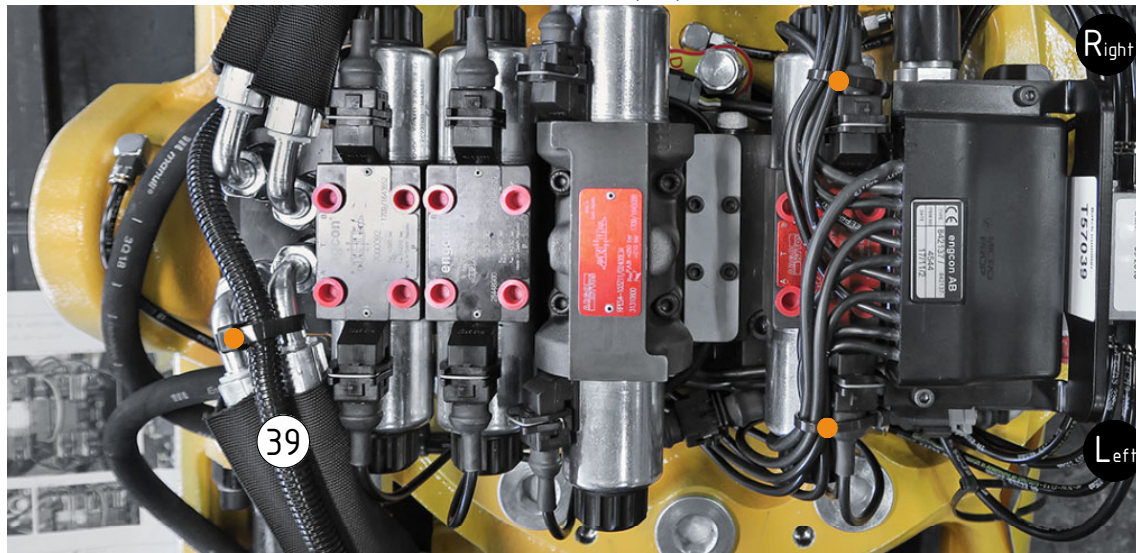

Cables Right (option)



EC214, EC219, EC226, EC233

POS	DESCRIPTION	PART	QTY	COMMENTS
34	Q-Safe connector			
35	Tiltrotator module DC2 Q-Safe	842137	1	
37	EC219: module turned 90° (see p.4) Cables assy. remains the same			
39	Aggregate cable DC2 Compl. QSC DT	8001201	1	
	● Use cable ties			

POS in order of assembly

Std. Valves & cables - ss10 (DC2/SVAB) QSM

Cables
DC2 EC-Oil

EC214, EC219, EC226, EC233

POS	DESCRIPTION	PART	QTY	COMMENTS
34	Q-Safe connector			
35	Tiltrotator module DC2 Q-Safe	842137	1	
37	EC219: module turned 90° (see p.4) Cables assy. remains the same			
41	Adapter cable ECOW DC2 DTM 2xM12	8001847	1	For EC-Oil. Instead of agg.cable
42	Protection plug DTM	8000090	1	
●	Use cable ties			

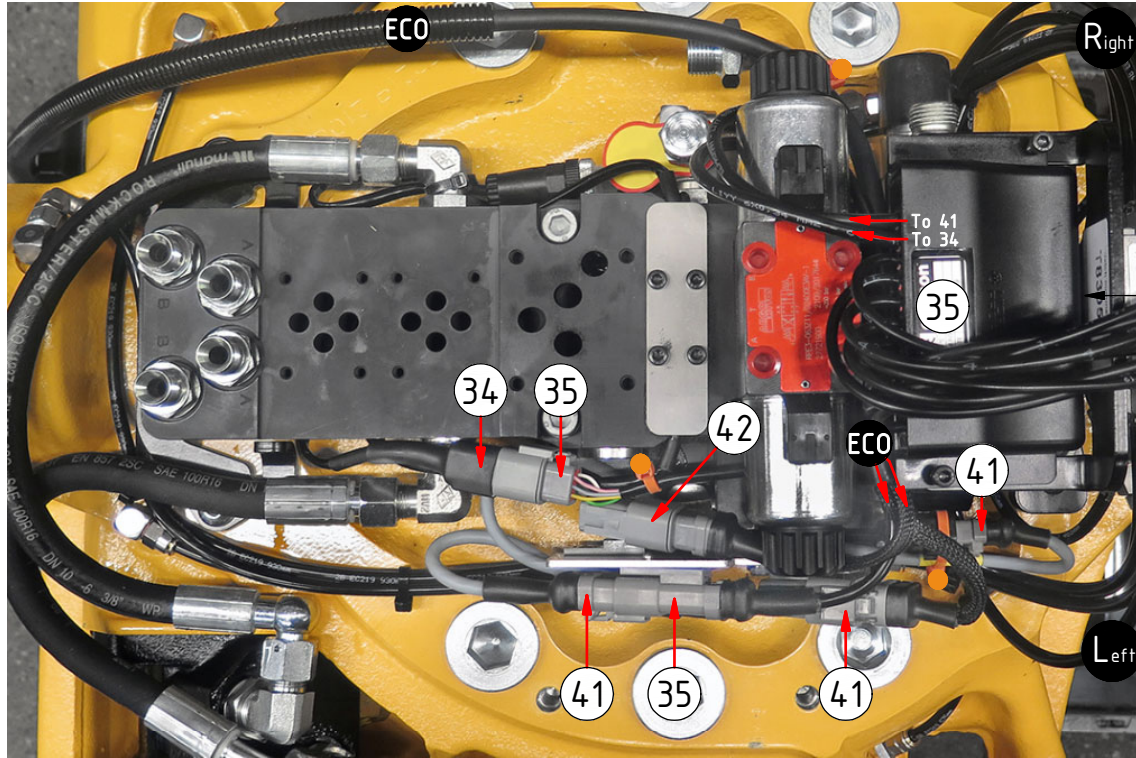

37

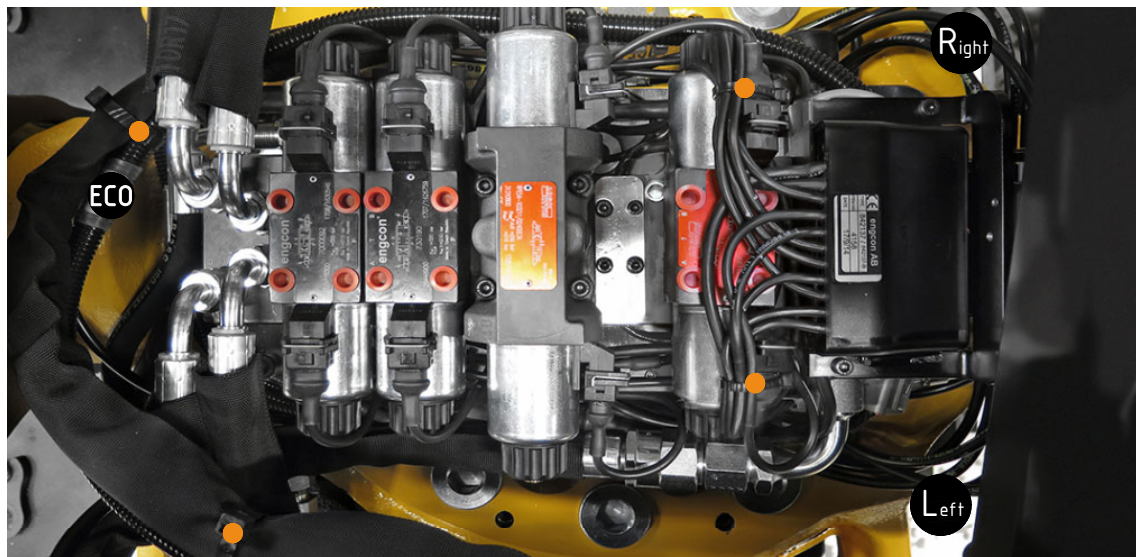

Lubrication

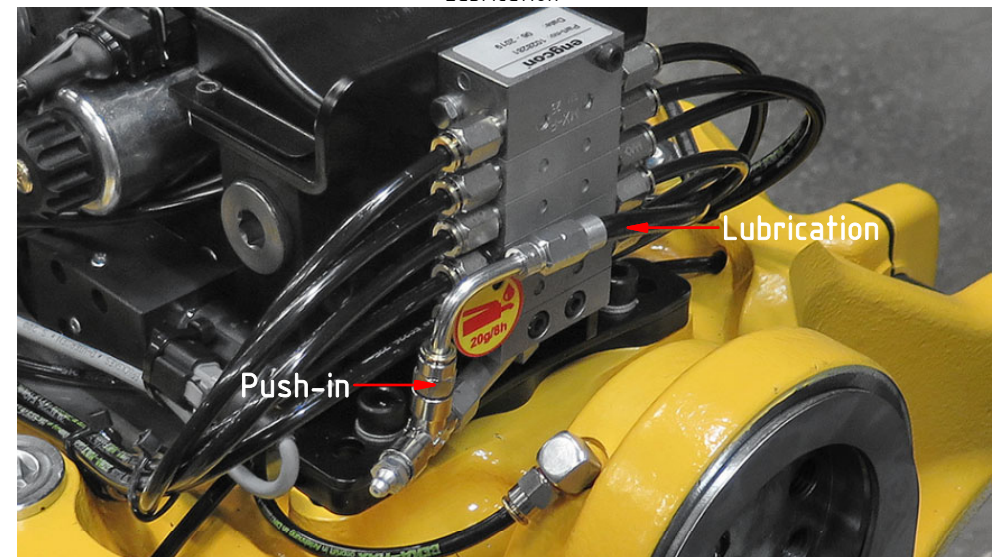

POS in order of assembly

Std. Valves & cables - ss10 (DC2/SVAB) QSM

POS in order of assembly

Cables

ss10 (SVAB) without EC-Oil

EC214, EC219, EC226, EC233

POS	DESCRIPTION	PART	QTY	COMMENTS
34	Q-Safe connector			
50	Adapter cable JT>DT (Lock valve)	1017478	1	(Previously also for DC2)
51	Aggregate cable SVAB Complete	1015196	1	
53	Cable QS QLM tiltrotator SVAB	842148	1	
●	Use cable ties			

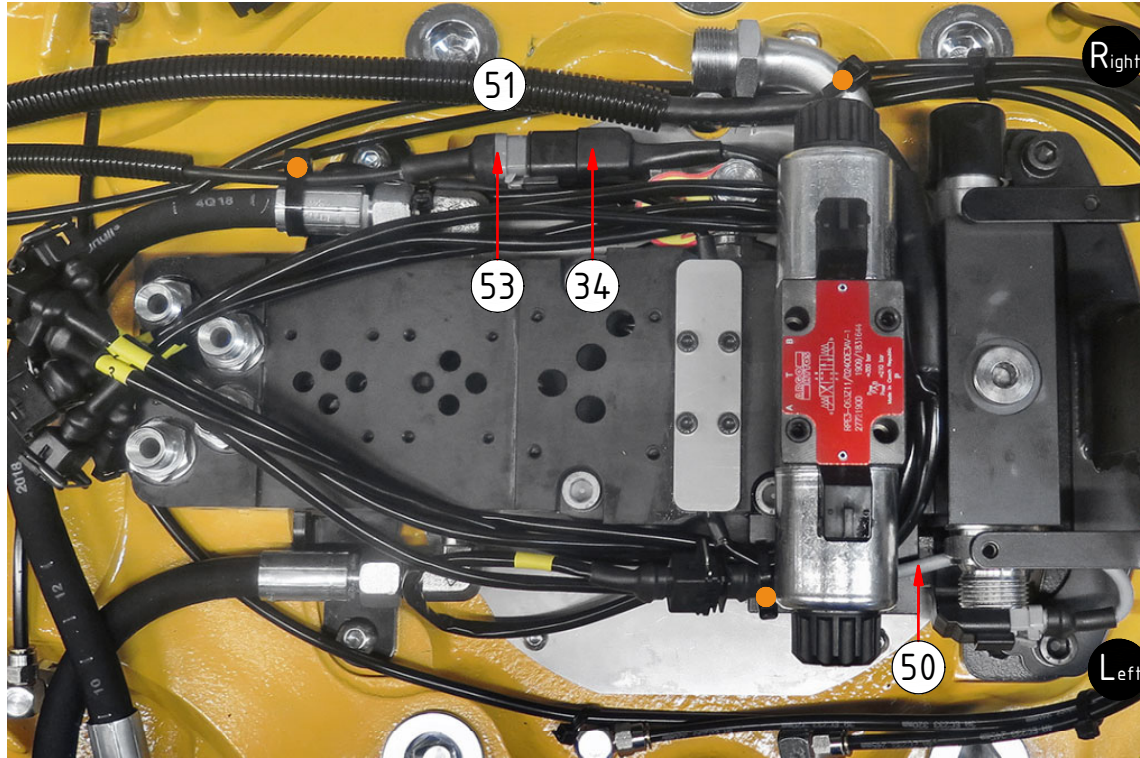

Cables Left (std)

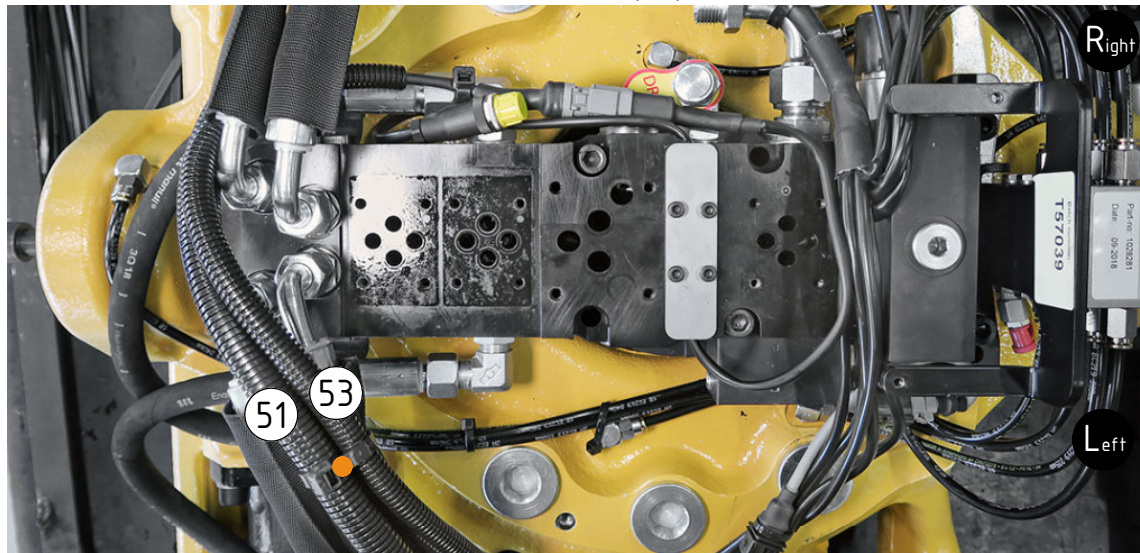

Cables Right (option)

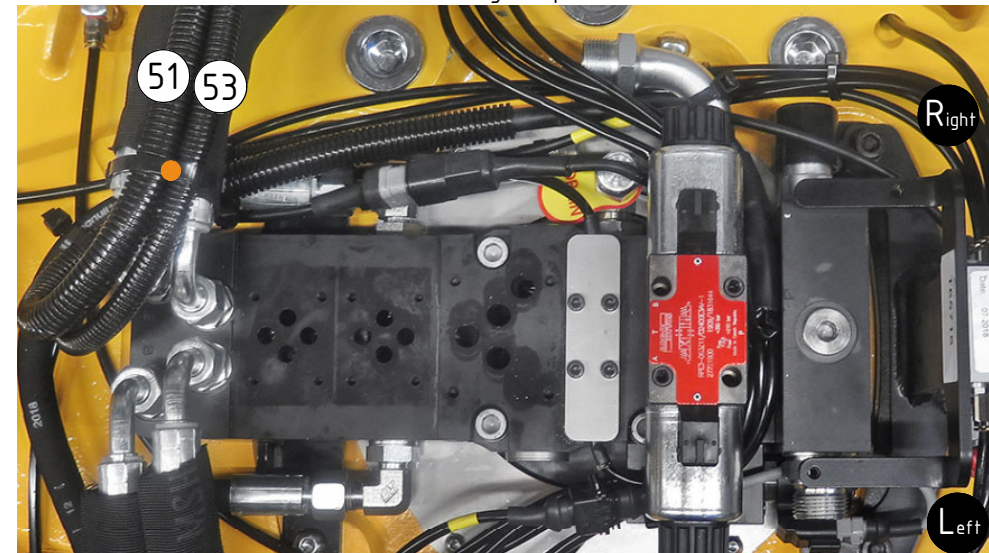

Valves

EC214, EC219, EC226, EC233

POS	DESCRIPTION	PART	QTY	COMMENTS
14	For option PROP on grab/extra			See p.11 for instruction

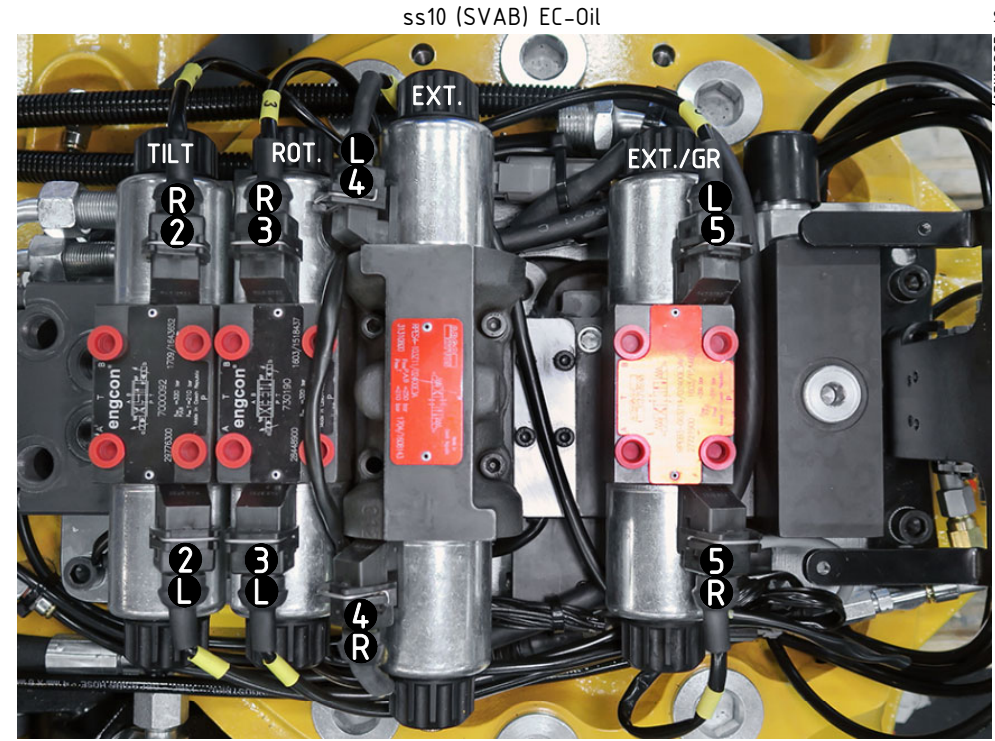
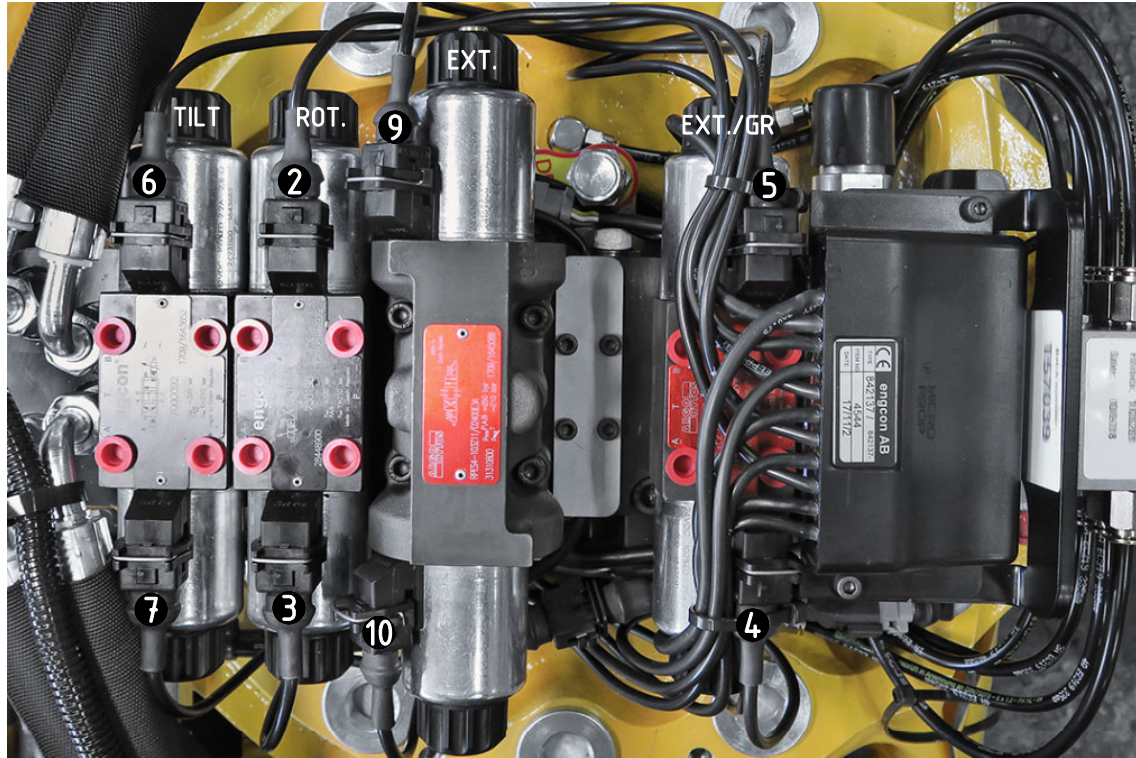

ss10 (SVAB) EC-Oil

(Right DT not connected)

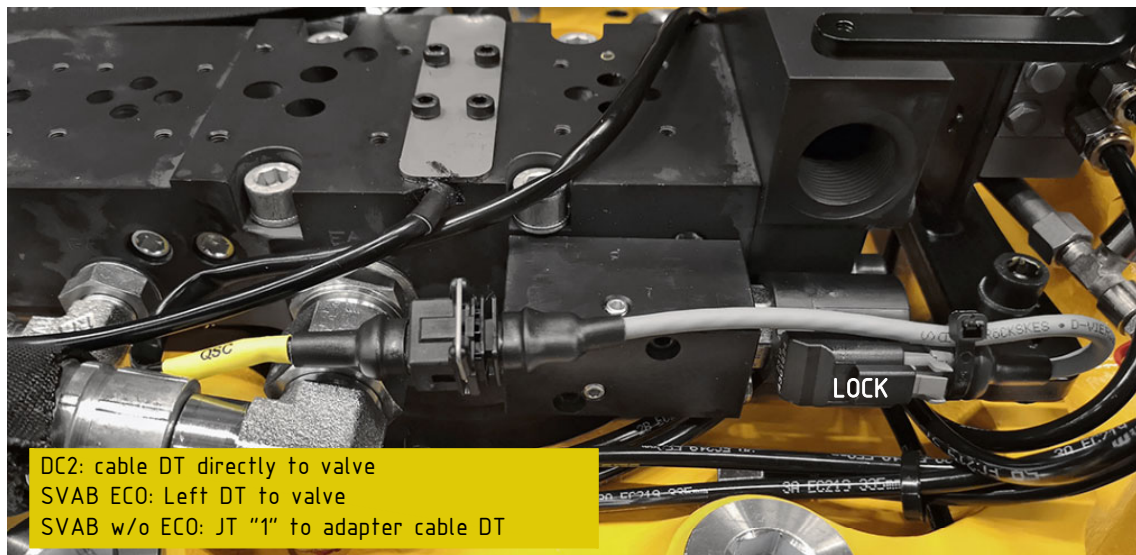

DC2: cable DT directly to valve
 SVAB ECO: Left DT to valve
 SVAB w/o ECO: JT "1" to adapter cable DT

POS in order of assembly

special/options

POS	DESCRIPTION	PART	QTY	COMMENTS
12	Directional valve prop 12V	730190	1	EC219-233 (POS.10, 17, 19 incl.)
15	O-ring square 12,42x1,68	750704	5	
22	Directional valve prop 12V	7001614	1	EC214 (POS.20, 27, 30 incl.)
32	Screw MC6S M5x30 12.9	610403	12	Torque: 9,7Nm
55	Adapter plate NG10-NG6	7000147	1	
56	Screw MC6S 6x25	6000083	4	Torque: 17Nm

POS in order of assembly

PROP valve on grab/extra

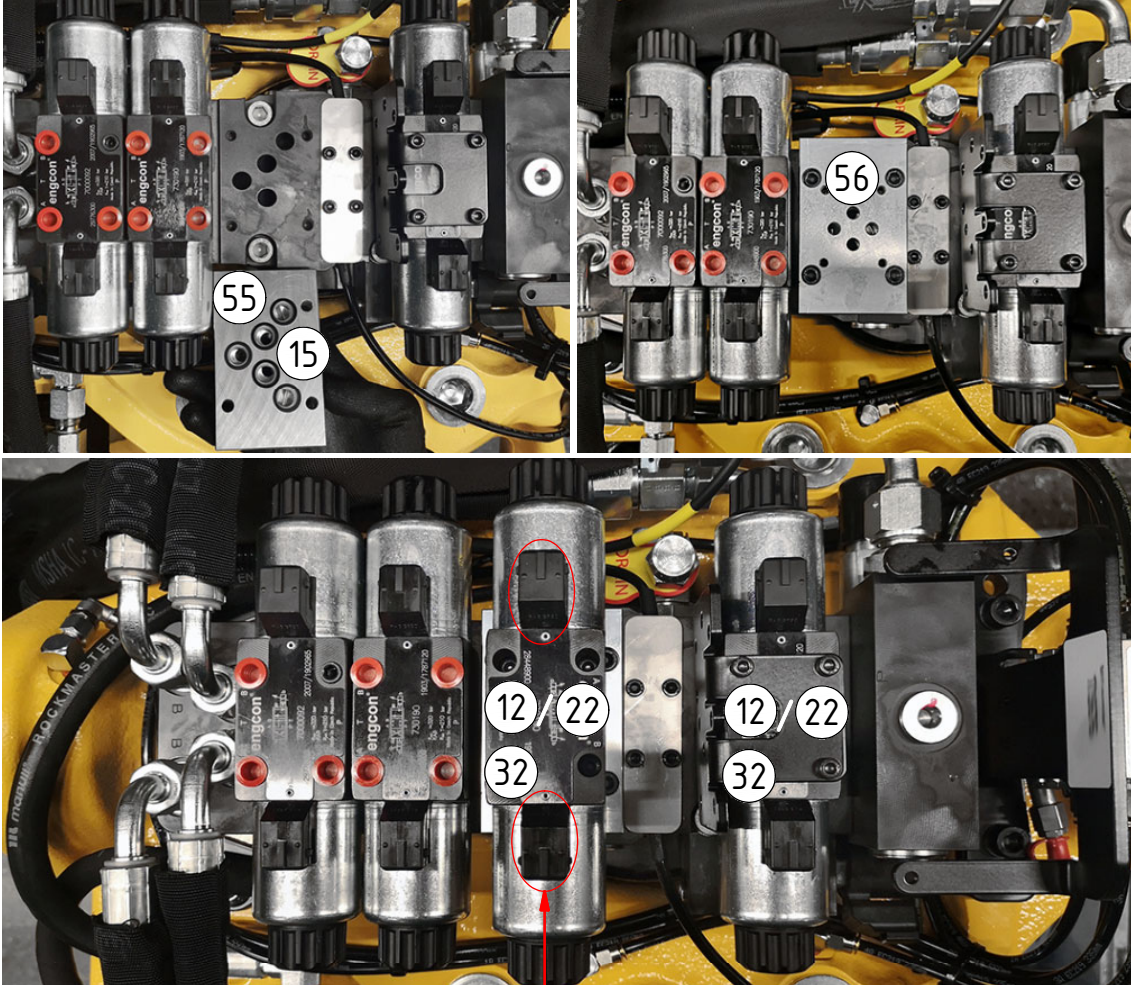

NB! Connectors for valves as standard config. *except* the connectors on EXTRA switches place as **encirkled**.

SPARE PARTS

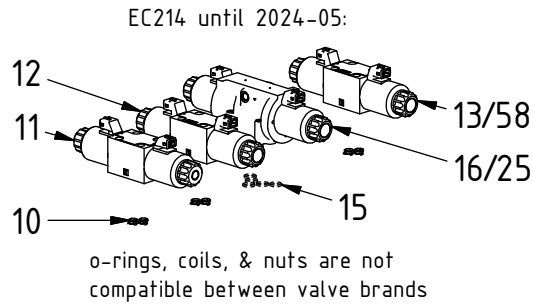

ePS1 DC2:

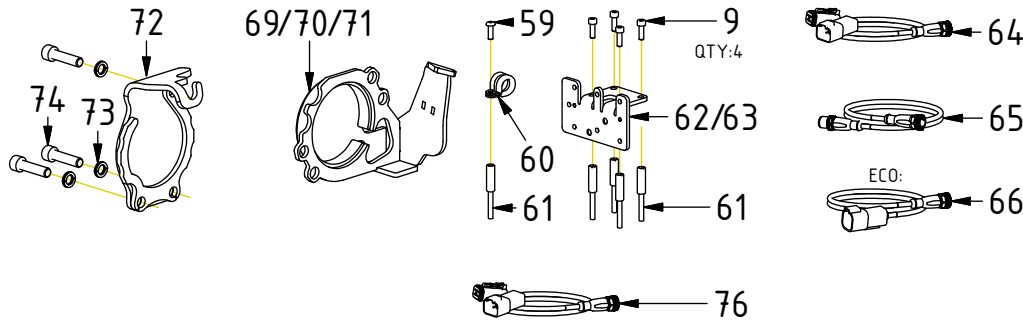

ePS1 ss10 (SVAB):

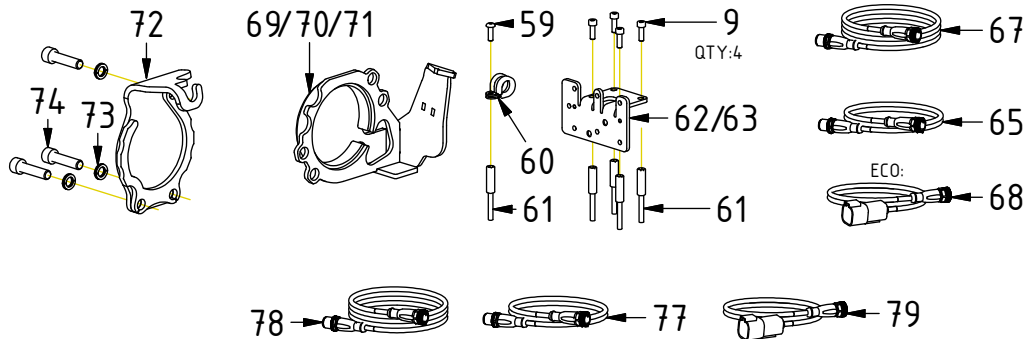

DC2 until 2020-12:

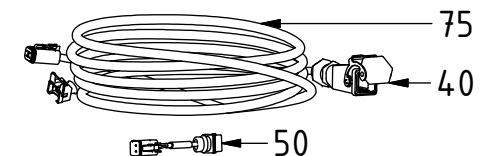

POS	DESCRIPTION	PART	QTY	COMMENTS
9	Screw MC6S M5x16 12.9	610401	2	Torque: 9,7Nm
10	O-ring 9,25x1,78	710901	12	
11	Directional valve prop 12V open T	7000092	1	EC219-233 (POS.10, 17, 19 incl.)
12	Directional valve prop 12V	730190	1	EC219-233 (POS.10, 17, 19 incl.)
13	Directional valve NG6 24V	730103	1	EC219-233 (POS.10, 18, 19 incl.)
15	O-ring square 12,42x1,68	750704	5	
16	Directional valve NG10 24V	730339	1	(POS.15, 18, 19 incl.)
17	Coil 12V prop JT	730192	4	
18	Coil 24V JT	730118	4	
19	Nut directional valve	730135	8	
25	Directional valve NG10 12V	730340	1	EC214 (POS.15, 26, 19 incl.)
26	Coil 12V JT	730117	2	
39	Aggregate cable DC2 Compl. QSC DT	8001201	1	
40	ILME cover	810208	1	(Incl. with agg.cable)
50	Adapter cable JT>DT (Lock valve)	1017478	1	(Previously also for DC2)
58	Directional valve NG6 12V	730101	1	(POS.10, 26, 19 incl.)
59	Screw K6S M5x16 10.9 FZB	611818	1	Torque: 8,1Nm
60	Rubber steel clamp ø16	6000009	1	
61	Valve spacer ePS1	1034402	5	
62	Bracket ePS1	1038119	1	For Topcon/LEICA/Novatron
63	Bracket ePS1 (Trimble only)	1038117	1	For Trimble
64	Adapter cable DC2 ePS	8000783	1	
65	Adapter cable ePS rotation sensor	8000784	1	
66	Cable Tilt angle sensor ECO W DC2	8002459	1	For EC-Oil w. ePS NB! Only compatible with 8002477
67	Unit cable ePS w. 120 ohm termin.	8000824	1	
68	Ad.cable ePS ECOW SVAB 120 ohm	8000825	1	For ECO w. ePS. Instead of POS.67
69	Protection EC214PS-EC219PS	1033565	1	
70	Protection EC233PS	1040940	1	
71	Protection EC226PS V2	1055677	1	
72	Protection EC226PS	1016554	1	Replaced by POS.71 from 2020-07
73	Washer NL 10mm	611041	3	
74	Screw MC6S M10x40 12.9	610453	3	
75	Aggregate cable DC2 Comp. QSC JT	8000175	1	Replaced by POS.39 from 2020-12
76	Adapter cable DC2 ePS DT DT M12	842173	1	Replaced by POS.64 from 2019-10
77	Adap. cable SVAB ePS rot. sensor	842188	1	Replaced by POS.65 from 2019-10
78	Agg. cable SVAB ePS rot. sensor	842187	1	Replaced by POS.67 from 2019-10
79	Adapter cable ePS ECO W SVAB	1042245	1	Replaced by POS.68 from 2019-10

POS in order of assembly