

COVERSHEET

Planned document changes:

Briefly:

No planned changes.

Document changes:

Date:	Change:	Rev. after change:
2023-08-18	Cables replaced.	G
2023-02-14	New ECO std. configurations from 2023.	F
2021-10-04	Part no for lubrication kit corrected.	E
2020-05-07	ECO couplings replaced. DC2 option 5hyd added.	D
2020-01-16	Spare parts and cover updated.	C
2019-12-10	EC050 W transport protection added.	B
2019-11-22	ECO ePS cables added. Spare parts added.	A
2018-08-15	New document.	-

Readers note:

 Indicates instruction.

 Represents Hose.

Dashed lines for overview, mounts
on other pages/assemblies.

- 4
- 5
- 6
- 7
- 8

Without EC-Oil

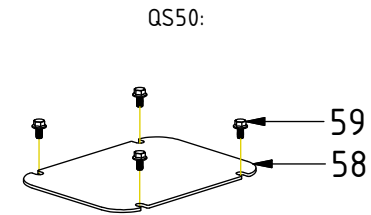
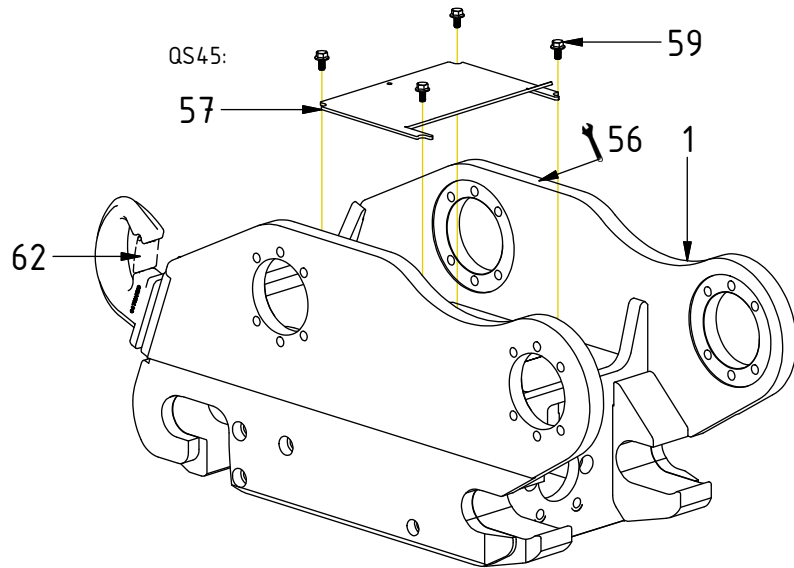
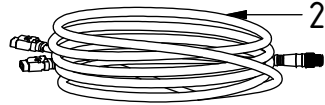

POS	DESCRIPTION	PART	QTY	COMMENTS
1	Quick hitch is selected via engcon			(Machine dependent)
2	Cable QS - QLM - Quick hitch	842149	1	Attach to QS sensors
4	Strain relief plate ZL87	8000704	2	
5	Blind rivet 4,0x12,3 DIN7337	6000294	10	
6	Holder Deutsch coupling	810662	6	
7	Screw K6S M5x8 10.9 FZB	611801	2	QTY: 3 for QS50 ECO
8	Rubber steel clamp \varnothing 10	6000003	2	QTY: 3 for QS50 ECO
56	Punch serial number into hitch			
57	Cover QS45 V3	1053624	1	
58	Cover QS45/QS50	1025581	1	Only for QS50 from 2019-10
59	Screw M6SF 8x12H Riffled	6000120	4	
62	Safety latch	404250	1	Lifting hook spare part

POS in order of assembly

Hoses

POS	DESCRIPTION	PART	QTY	COMMENTS
9	Washer GBR04 1/4	710702	2	
10	Adapter 138-04-29 (1/4")	710135	2	
11	Hose Lock	741505	2	
12	Hose Lock - Liebherr	7000560	2	
13	Hose Lock - Lännen	7000561	2	
14	Hose Lock - Huddig	7001484	2	

POS in order of assembly

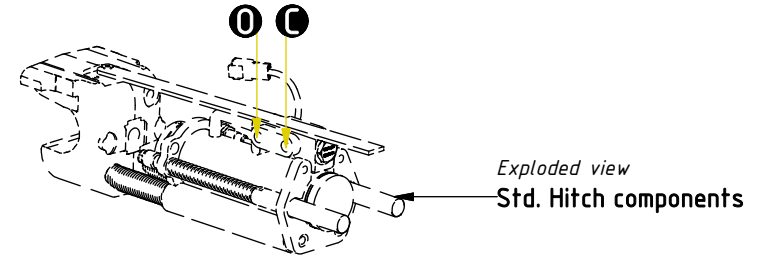
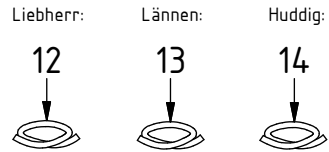
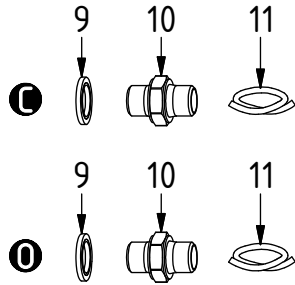

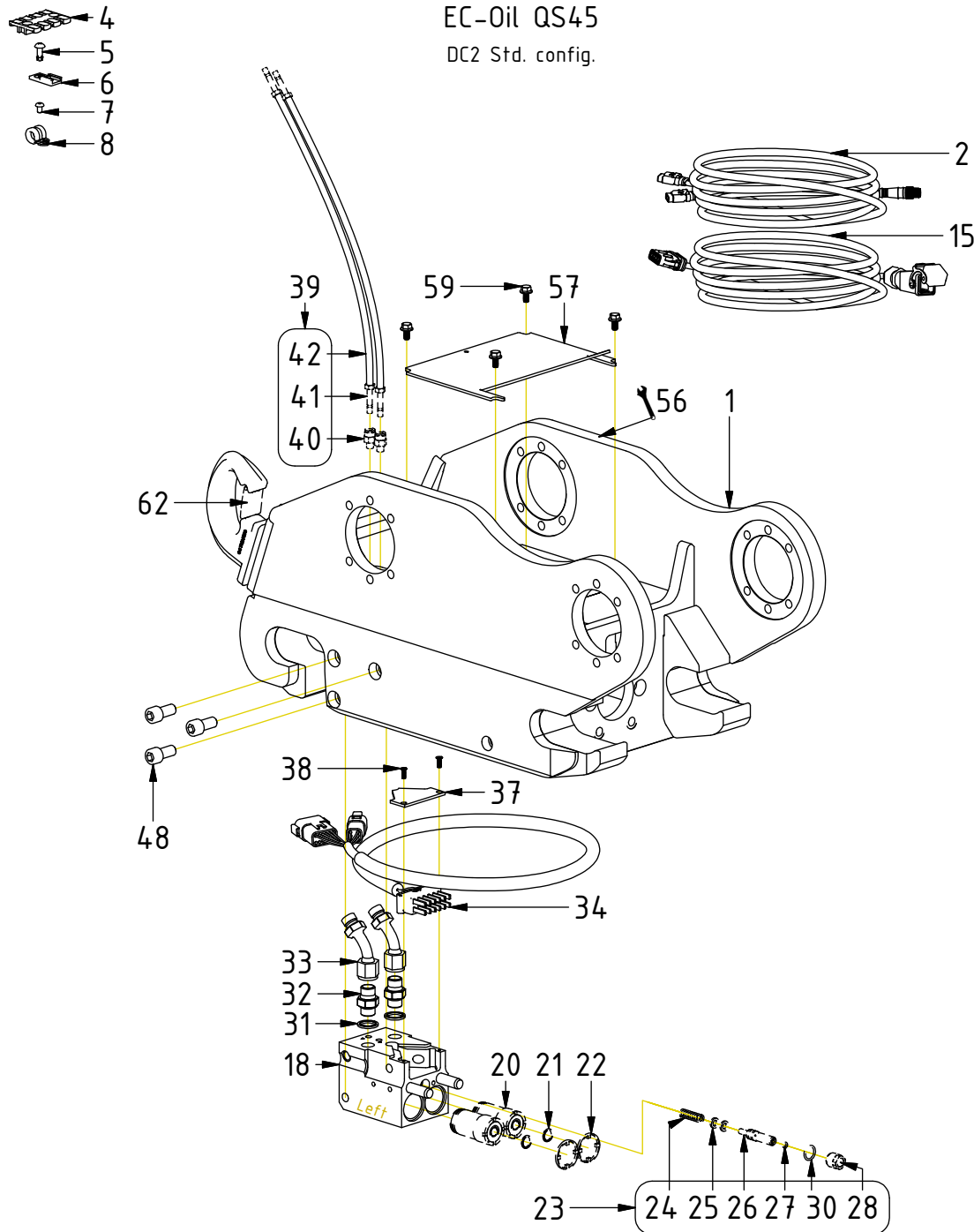

POS	DESCRIPTION	PART	QTY	COMMENTS
1	Quick hitch is selected via engcon			(Machine dependent)
2	Cable QS - QLM - Quick hitch	842149	1	Attach to QS sensors
4	Strain relief plate ZL87	8000704	2	
5	Blind rivet 4,0x12,3 DIN7337	6000294	10	
6	Holder Deutsch coupling	810662	6	
7	Screw K6S M5x8 10.9 FZB	611801	2	QTY: 3 for QS50 ECO
8	Rubber steel clamp ø10	6000003	2	QTY: 3 for QS50 ECO
15	Machine cable ECO45/50 W DC2	1048527	1	Attach to 12P
18	Block ECO45W Hitch 2hy,1cl. Compl.	1055711	1	(POS.20, 22-23 incl.)
20	Coupling ECO W 3/8" V3	1053029	2	Torque: 60Nm. (POS.21 incl.)
21	Flat sealing for ECO W 3/8" V3	1052976	2	
22	Dirt protection block ECO 3/8"	1028274	2	
23	Lubrication kit ECO W	1050794	1	(POS.24-30 incl.)
24	Spring 6058	1024113	1	
25	Piston sealing KPOR130 12x7,1x2,2	1024112	2	(O-ring included with seal ring)
26	Grease piston	1024111	1	
27	O-ring 3,69x1,78	1024115	1	
28	Nut grease piston	1047688	1	Wrap with thread sealing tape
29	O-ring 9,25x1,78	712429	1	Located inside POS.28
30	O-ring 14x2	7000767	1	
31	Washer GBR06 3/8	710703	2	
32	Adapter 136-06-06 (3/8")	710106	2	
33	Adapter 489-06-06 45° (3/8")	710164	2	Loxeal 55-02
34	Power plug ECO45 W Hitch	1042244	1	Cable gland torque: 6Nm
37	Coverplate block ECO45 W Hitch	1041098	1	
38	Screw MKFT 4x12	6000121	2	
39	Hose kit - lubricant ECO W	7000514	1	(POS.40-42 incl.)
40	Straight Push-in M8x1	790185	2	
41	Pipe stub straight Push-in	790175	2	
42	Hose 2m - lubricant ECO	790176	2	
48	Screw MC6S M12x25 12.9 ZFSHL	6000164	3	Loxeal 83-52
56	Punch serial number into hitch			
57	Cover QS45 V3	1053624	1	
59	Screw M6SF 8x12H Riffled	6000120	4	
60	Transport Protection ECO45-Block	1047812	1	Part of make up
62	Safety latch	404250	1	Lifting hook spare part

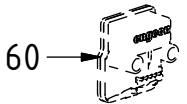

POS in order of assembly

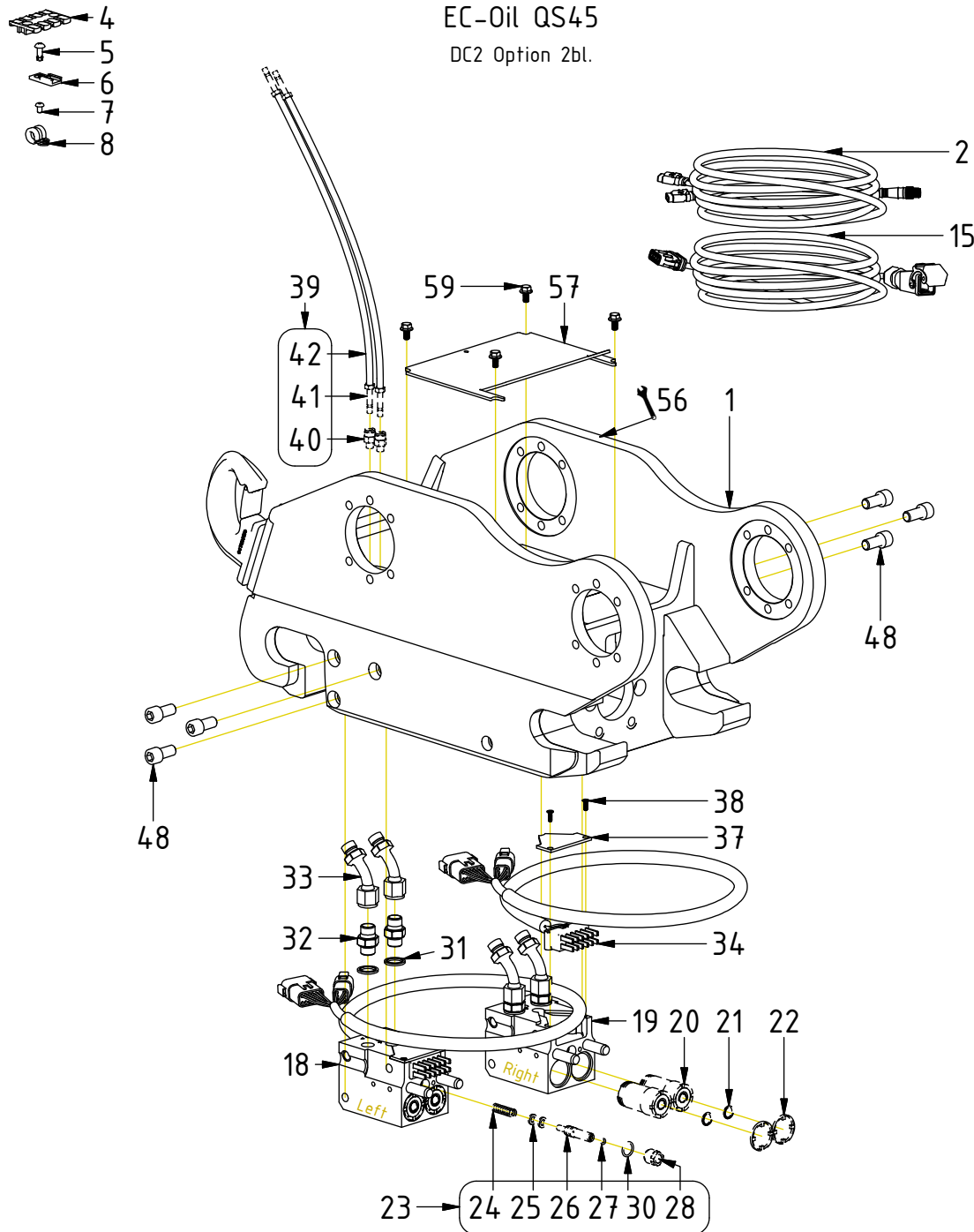

POS	DESCRIPTION	PART	QTY	COMMENTS
1	Quick hitch is selected via engcon			(Machine dependent)
2	Cable QS - QLM - Quick hitch	842149	1	Attach to QS sensors
4	Strain relief plate ZL87	8000704	2	
5	Blind rivet 4,0x12,3 DIN7337	6000294	10	
6	Holder Deutsch coupling	810662	6	
7	Screw K6S M5x8 10.9 FZB	611801	2	QTY: 3 for QS50 ECO
8	Rubber steel clamp ø10	6000003	2	QTY: 3 for QS50 ECO
9	Washer GBR04 1/4	710702	2	
10	Adapter 138-04-29 (1/4")	710135	2	
15	Machine cable ECO45/50 W DC2	1048527	1	Attach to Left 12P
18	Block ECO45W Hitch 2hy.1cl. Compl.	1055711	1	(POS.20, 22-23 incl.)
19	Block ECO45W Hitch 2hy. Complete	1055712	1	(POS.20, 22 incl.)
20	Coupling ECO W 3/8" V3	1053029	2	Torque: 60Nm. (POS.21 incl.)
21	Flat sealing for ECO W 3/8" V3	1052976	2	
22	Dirt protection block ECO 3/8"	1028274	2	
23	Lubrication kit ECO W	1050794	1	(POS.24-30 incl.)
24	Spring 6058	1024113	1	
25	Piston sealing KPOR130 12x7,1x2,2	1024112	2	(O-ring included with seal ring)
26	Grease piston	1024111	1	
27	O-ring 3,69x1,78	1024115	1	
28	Nut grease piston	1047688	1	Wrap with thread sealing tape
29	O-ring 9,25x1,78	712429	1	Located inside POS.28
30	O-ring 14x2	7000767	1	
31	Washer GBR06 3/8	710703	2	
32	Adapter 136-06-06 (3/8")	710106	2	
33	Adapter 489-06-06 45° (3/8")	710164	2	Loxreal 55-02
34	Power plug ECO45 W Hitch	1042244	1	Cable gland torque: 6Nm
37	Coverplate block ECO45 W Hitch	1041098	1	
38	Screw MKFT 4x12	6000121	2	
39	Hose kit - lubricant ECO W	7000514	1	(POS.40-42 incl.)
40	Straight Push-in M8x1	790185	2	
41	Pipe stub straight Push-in	790175	2	
42	Hose 2m - lubricant ECO	790176	2	
43	Block ECO45W Hitch 3hy. Complete	1054417	1	(POS.20, 22, 44, 46 incl.)
44	Coupling ECO 1/4" V3	1053683	1	(POS.45 incl.)
45	Flat sealing for ECO 1/4" V3	1053936	1	
46	Dirt protection block ECO 1/4"	1054419	1	
47	Adapter 489-04-04 45° (1/4")	710163	1	
48	Screw MC6S M12x25 12.9 ZFSHL	6000164	3	Loxreal 83-52
56	Punch serial number into hitch			
57	Cover QS45 V3	1053624	1	
59	Screw M6SF 8x12H Riffled	6000120	4	
60	Transport Protection ECO45-Block	1047812	1	Part of make up

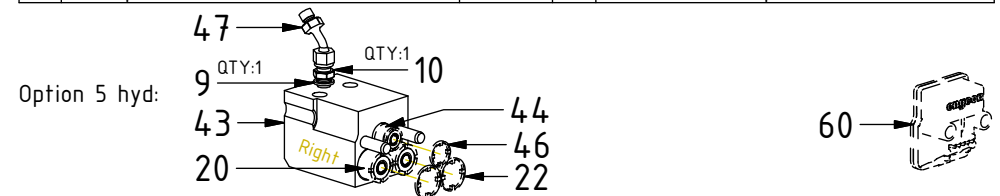

POS in order of assembly

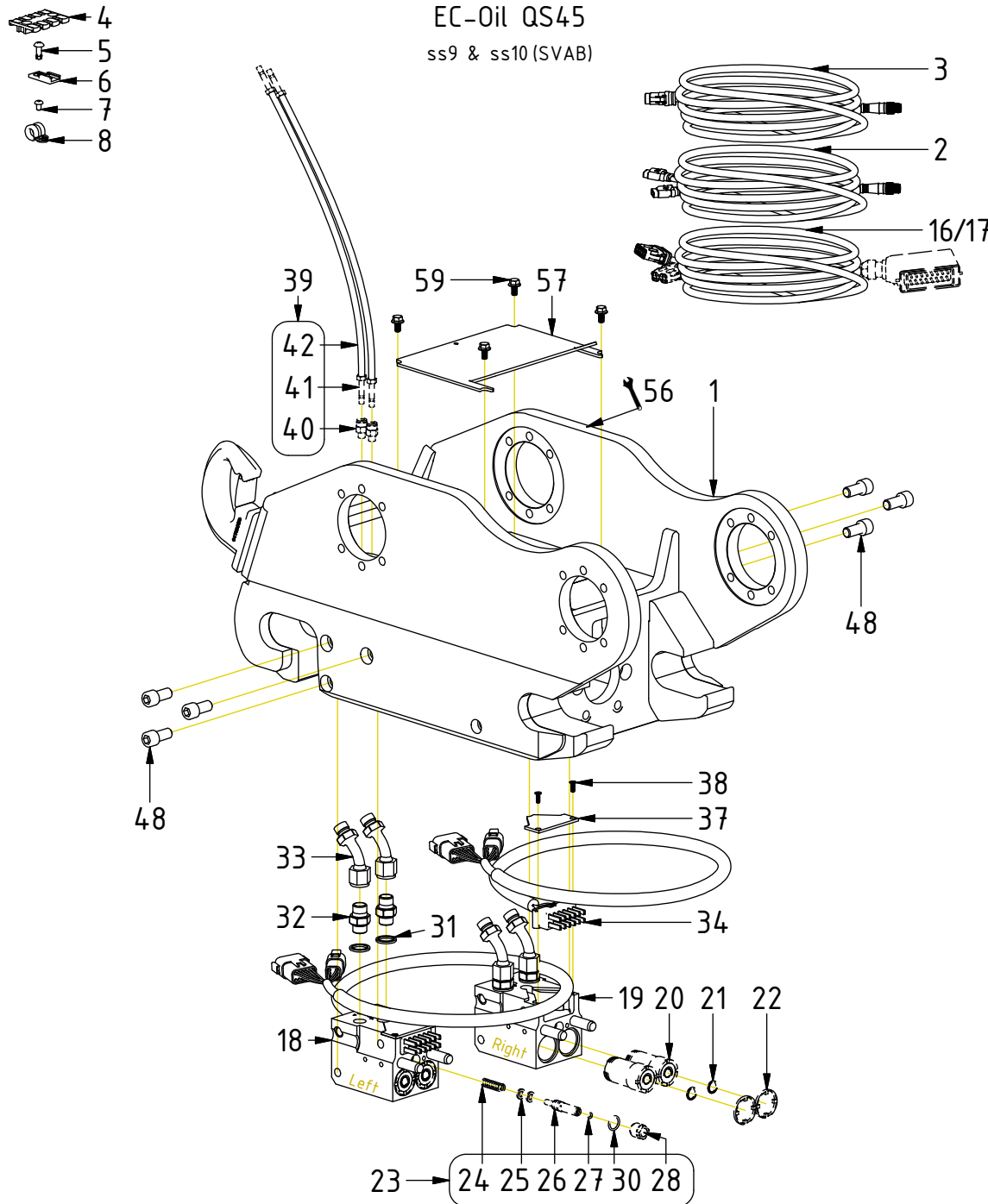

POS	DESCRIPTION	PART	QTY	COMMENTS
1	Quick hitch is selected via engcon			(Machine dependent)
2	Cable QS - QLM - Quick hitch	842149	1	Attach to QS sensors
3	Cable QS - QLM - Tilt rotator	842148	1	Attach to Left 6P
4	Strain relief plate ZL87	8000704	2	
5	Blind rivet 4,0x12,3 DIN7337	6000294	10	
6	Holder Deutsch coupling	810662	6	
7	Screw K6S M5x8 10.9 FZB	611801	2	QTY: 3 for QS50 ECO
8	Rubber steel clamp ø10	6000003	2	QTY: 3 for QS50 ECO
16	Machinecable ECO W ss9-2 (1x 12P)	1036844	1	Attach to Left 12P
17	Machinecable ECO W SVAB (2x 12P)	8002008	1	Attach to both 12P
18	Block ECO45W Hitch 2hy.1cl. Compl.	1055711	1	(POS.20, 22-23 incl.)
19	Block ECO45W Hitch 2hy. Complete	1055712	1	(POS.20, 22 incl.)
20	Coupling ECO W 3/8" V3	1053029	2	Torque: 60Nm. (POS.21 incl.)
21	Flat sealing for ECO W 3/8" V3	1052976	2	
22	Dirt protection block ECO 3/8"	1028274	2	
23	Lubrication kit ECO W	1050794	1	(POS.24-30 incl.)
24	Spring 6058	1024113	1	
25	Piston sealing KPOR130 12x7,1x2,2	1024112	2	(O-ring included with seal ring)
26	Grease piston	1024111	1	
27	O-ring 3,69x1,78	1024115	1	
28	Nut grease piston	1047688	1	Wrap with thread sealing tape
29	O-ring 9,25x1,78	712429	1	Located inside POS.28
30	O-ring 14x2	7000767	1	
31	Washer GBR06 3/8	710703	2	
32	Adapter 136-06-06 (3/8")	710106	2	
33	Adapter 489-06-06 45° (3/8")	710164	2	Loxéal 55-02
34	Power plug ECO45 W Hitch	1042244	1	Cable gland torque: 6Nm
37	Coverplate block ECO45 W Hitch	1041098	1	
38	Screw MKFT 4x12	6000121	2	
39	Hose kit - lubricant ECO W	7000514	1	(POS.40-42 incl.)
40	Straight Push-in M8x1	790185	2	
41	Pipe stub straight Push-in	790175	2	
42	Hose 2m - lubricant ECO	790176	2	
48	Screw MC6S M12x25 12.9 ZFSL	6000164	3	Loxéal 83-52
55	Cable ePS ECO W ss9,ss10(SVAB)	1042246	1	Attach to Right 6P
56	Punch serial number into hitch			
57	Cover QS45 V3	1053624	1	
59	Screw M6SF 8x12H Riffled	6000120	4	
60	Transport Protection ECO45-Block	1047812	1	Part of make up

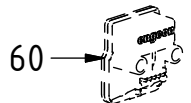
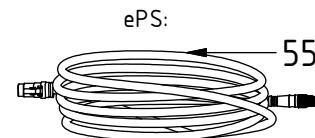

POS in order of assembly

Machine hitch - QS45/QS50

- 5
- 6
- 7
- 8

EC-Oil QS50
DC2 Std. config.

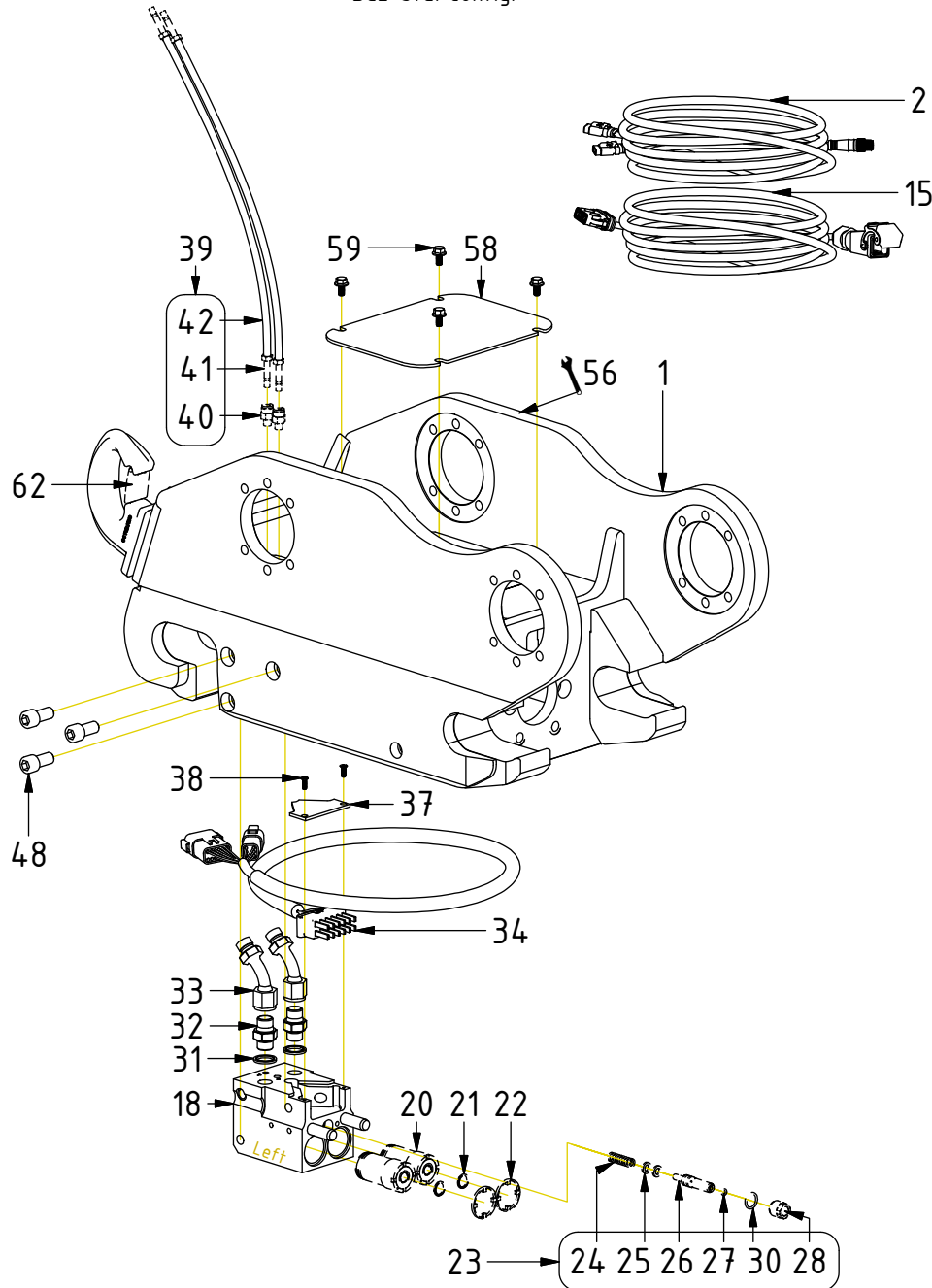

POS	DESCRIPTION	PART	QTY	COMMENTS
1	Quick hitch is selected via engcon			(Machine dependent)
2	Cable QS - QLM - Quick hitch	842149	1	Attach to QS sensors
5	Blind rivet 4,0x12,3 DIN7337	6000294	10	
6	Holder Deutsch coupling	810662	6	
7	Screw K6S M5x8 10.9 FZB	611801	2	QTY: 3 for QS50 ECO
8	Rubber steel clamp ø10	6000003	2	QTY: 3 for QS50 ECO
15	Machine cable ECO45/50 W DC2	1048527	1	Attach to 12P
18	Block ECO45W Hitch 2hy.1cl. Compl.	1055711	1	(POS.20, 22-23 incl.)
20	Coupling ECO W 3/8" V3	1053029	2	Torque: 60Nm. (POS.21 incl.)
21	Flat sealing for ECO W 3/8" V3	1052976	2	
22	Dirt protection block ECO 3/8"	1028274	2	
23	Lubrication kit ECO W	1050794	1	(POS.24-30 incl.)
24	Spring 6058	1024113	1	
25	Piston sealing KPOR130 12x7,1x2,2	1024112	2	(O-ring included with seal ring)
26	Grease piston	1024111	1	
27	O-ring 3,69x1,78	1024115	1	
28	Nut grease piston	1047688	1	Wrap with thread sealing tape
29	O-ring 9,25x1,78	712429	1	Located inside POS.28
30	O-ring 14x2	7000767	1	
31	Washer GBR06 3/8	710703	2	
32	Adapter 136-06-06 (3/8")	710106	2	
33	Adapter 489-06-06 45° (3/8")	710164	2	Loxéal 55-02
34	Power plug ECO45 W Hitch	1042244	1	Cable gland torque: 6Nm
37	Coverplate block ECO45 W Hitch	1041098	1	
38	Screw MKFT 4x12	6000121	2	
39	Hose kit - lubricant ECO W	7000514	1	(POS.40-42 incl.)
40	Straight Push-in M8x1	790185	2	
41	Pipe stub straight Push-in	790175	2	
42	Hose 2m - lubricant ECO	790176	2	
48	Screw MC6S M12x25 12.9 ZFSHL	6000164	3	Loxéal 83-52
56	Punch serial number into hitch			
58	Cover QS45/QS50	1025581	1	Only for QS50 from 2019-10
59	Screw M6SF 8x12H Riffled	6000120	4	
60	Transport Protection ECO45-Block	1047812	1	Part of make up
62	Safety latch	404250	1	Lifting hook spare part

POS in order of assembly

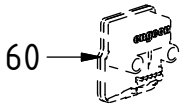

Machine hitch - QS45/QS50

- 5
- 6
- 7
- 8

EC-Oil QS50
DC2 Option 2bl.

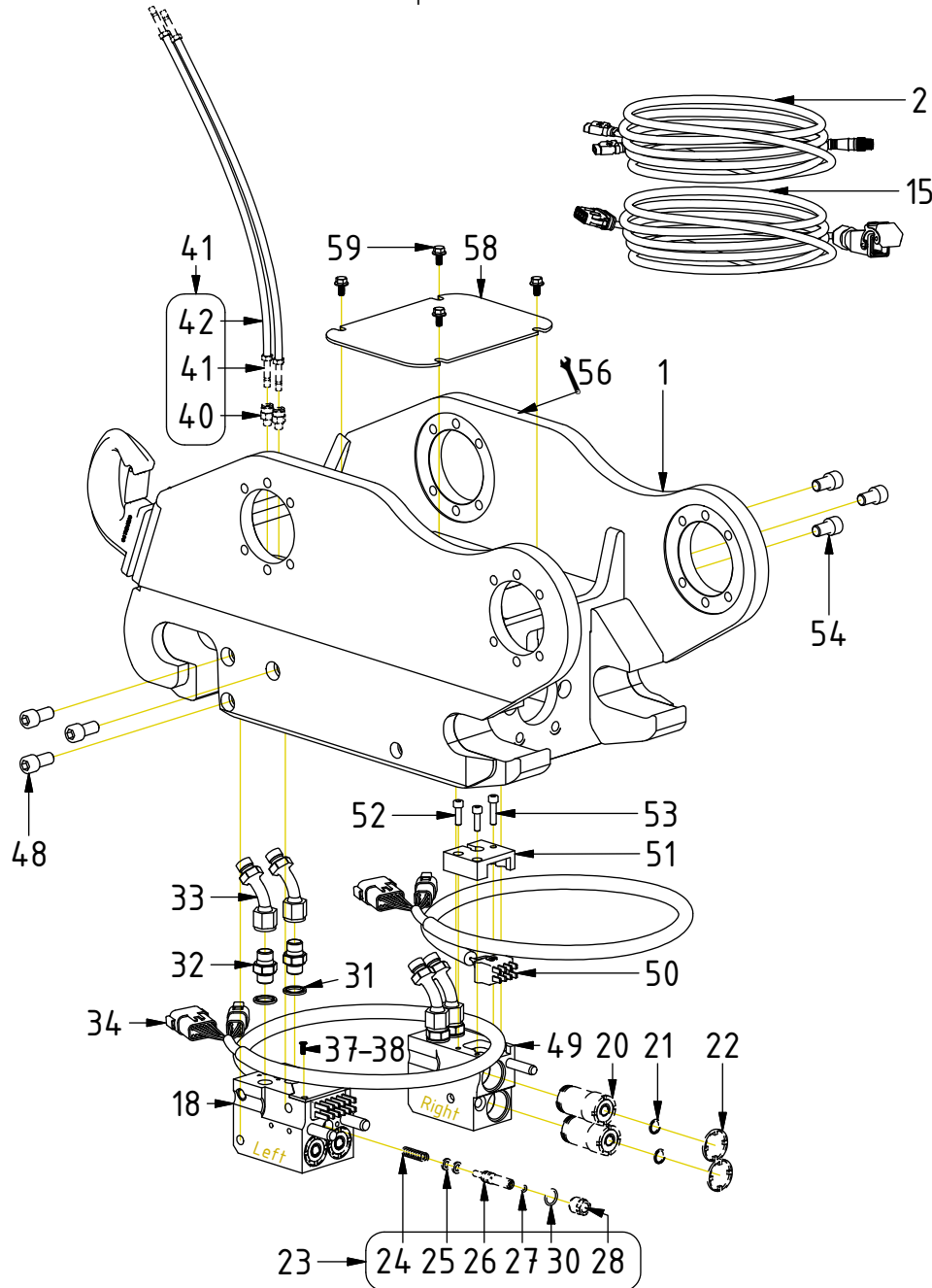

POS	DESCRIPTION	PART	QTY	COMMENTS
1	Quick hitch is selected via engcon			(Machine dependent)
2	Cable QS - QLM - Quick hitch	842149	1	Attach to QS sensors
5	Blind rivet 4,0x12,3 DIN7337	6000294	10	
6	Holder Deutsch coupling	810662	6	
7	Screw K6S M5x8 10.9 FZB	611801	2	QTY: 3 for QS50 ECO
8	Rubber steel clamp \varnothing 10	6000003	2	QTY: 3 for QS50 ECO
15	Machine cable ECO45/50 W DC2	1048527	1	Attach to Left 12P
18	Block ECO45W Hitch 2hy.1cl. Compl.	1055711	1	(POS.20, 22-23 incl.)
20	Coupling ECO W 3/8" V3	1053029	2	Torque: 60Nm. (POS.21 incl.)
21	Flat sealing for ECO W 3/8" V3	1052976	2	
22	Dirt protection block ECO 3/8"	1028274	2	
23	Lubrication kit ECO W	1050794	1	(POS.24-30 incl.)
24	Spring 6058	1024113	1	
25	Piston sealing KPOR130 12x7,1x2,2	1024112	2	(O-ring included with seal ring)
26	Grease piston	1024111	1	
27	O-ring 3,69x1,78	1024115	1	
28	Nut grease piston	1047688	1	Wrap with thread sealing tape
29	O-ring 9,25x1,78	712429	1	Located inside POS.28
30	O-ring 14x2	7000767	1	
31	Washer GBR06 3/8	710703	2	
32	Adapter 136-06-06 (3/8")	710106	2	
33	Adapter 489-06-06 45° (3/8")	710164	2	Loxéal 55-02
34	Power plug ECO45 W Hitch	1042244	1	Cable gland torque: 6Nm
37	Coverplate block ECO45 W Hitch	1041098	1	
38	Screw MKFT 4x12	6000121	2	
39	Hose kit - lubricant ECO W	7000514	1	(POS.40-42 incl.)
40	Straight Push-in M8x1	790185	2	
41	Pipe stub straight Push-in	790175	2	
42	Hose 2m - lubricant ECO	790176	2	
48	Screw MC6S M12x25 12.9 ZFSHL	6000164	3	Loxéal 83-52
49	Block ECO50W Hitch 2hy. Complete	1055714	1	(POS.20, 22 incl.)
50	Power plug ECO50 W Hitch (QSM)	8002007	1	Cable gland torque: 6Nm
51	Coverplate block ECO50 W Hitch	1041647	1	
52	Screw MC6S M6x20 12.9	610414	2	
53	Screw MC6S M6x25 12.9	6000083	1	
54	Screw MC6S M12x20 12.9	610472	3	Loxéal 83-52
56	Punch serial number into hitch			
58	Cover QS45/QS50	1025581	1	Only for QS50 from 2019-10
59	Screw M6SF 8x12H Riffled	6000120	4	
60	Transport Protection ECO45-Block	1047812	1	Part of make up
61	Transport Protection ECO50-Block	1049167	2	Part of make up



POS in order of assembly

Machine hitch - QS45/QS50

- 5
- 6
- 7
- 8

EC-Oil QS50
ss9 & ss10 (SVAB)

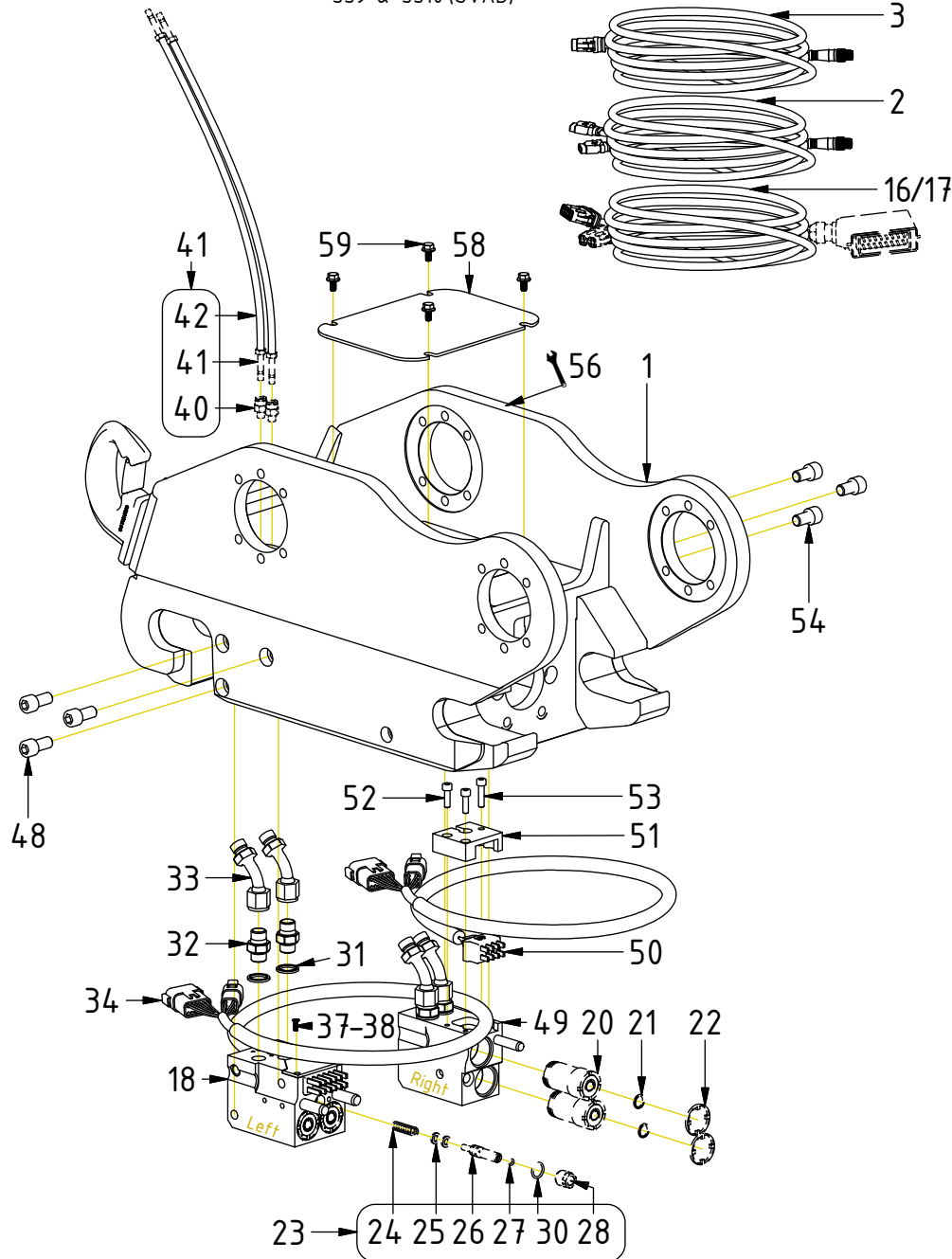

POS	DESCRIPTION	PART	QTY	COMMENTS
1	Quick hitch is selected via engcon			(Machine dependent)
2	Cable QS - QLM - Quick hitch	842149	1	Attach to QS sensors
3	Cable QS - QLM - Tilt rotator	842148	1	Attach to Left 6P
5	Blind rivet 4,0x12,3 DIN7337	6000294	10	
6	Holder Deutsch coupling	810662	6	
7	Screw K6S M5x8 10.9 FZB	611801	2	QTY: 3 for QS50 ECO
8	Rubber steel clamp ø10	6000003	2	QTY: 3 for QS50 ECO
16	Machinecable ECO W ss9-2 (1x 12P)	1036844	1	Attach to Left 12P
17	Machinecable ECO W SVAB (2x 12P)	8002008	1	Attach to both 12P
18	Block ECO45W Hitch 2hy.1cl. Compl.	1055711	1	(POS.20, 22-23 incl.)
20	Coupling ECO W 3/8" V3	1053029	2	Torque: 60Nm. (POS.21 incl.)
21	Flat sealing for ECO W 3/8" V3	1052976	2	
22	Dirt protection block ECO 3/8"	1028274	2	
23	Lubrication kit ECO W	1050794	1	(POS.24-30 incl.)
24	Spring 6058	1024113	1	
25	Piston sealing KPOR130 12x7,1x2,2	1024112	2	(O-ring included with seal ring)
26	Grease piston	1024111	1	
27	O-ring 3,69x1,78	1024115	1	
28	Nut grease piston	1047688	1	Wrap with thread sealing tape
29	O-ring 9,25x1,78	712429	1	Located inside POS.28
30	O-ring 14x2	7000767	1	
31	Washer GBR06 3/8	710703	2	
32	Adapter 136-06-06 (3/8")	710106	2	
33	Adapter 489-06-06 45° (3/8")	710164	2	Loxéal 55-02
34	Power plug ECO45 W Hitch	1042244	1	Cable gland torque: 6Nm
37	Coverplate block ECO45 W Hitch	1041098	1	
38	Screw MKFT 4x12	6000121	2	
39	Hose kit - lubricant ECO W	7000514	1	(POS.40-42 incl.)
40	Straight Push-in M8x1	790185	2	
41	Pipe stub straight Push-in	790175	2	
42	Hose 2m - lubricant ECO	790176	2	
48	Screw MC6S M12x25 12.9 ZFSHL	6000164	3	Loxéal 83-52
49	Block ECO50W Hitch 2hy. Complete	1055714	1	(POS.20, 22 incl.)
50	Power plug ECO50 W Hitch (QSM)	8002007	1	Cable gland torque: 6Nm
51	Coverplate block ECO50 W Hitch	1041647	1	
52	Screw MC6S M6x20 12.9	610414	2	
53	Screw MC6S M6x25 12.9	6000083	1	
54	Screw MC6S M12x20 12.9	610472	3	Loxéal 83-52
55	Cable ePS ECO W ss9,ss10(SVAB)	1042246	1	Attach to Right 6P
56	Punch serial number into hitch			
58	Cover QS45/QS50	1025581	1	Only for QS50 from 2019-10
59	Screw M6SF 8x12H Riffled	6000120	4	
60	Transport Protection ECO45-Block	1047812	1	Part of make up
61	Transport Protection ECO50-Block	1049167	2	Part of make up



POS in order of assembly

Without EC-Oil
QS45:

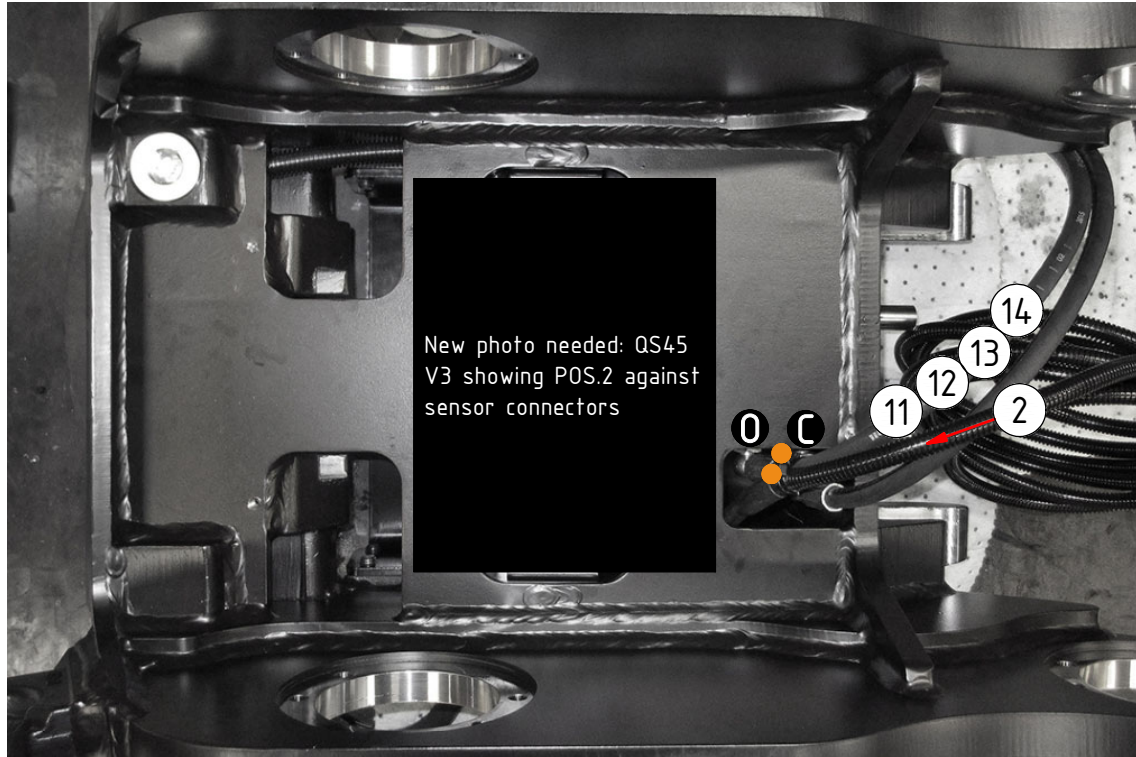

QS50:

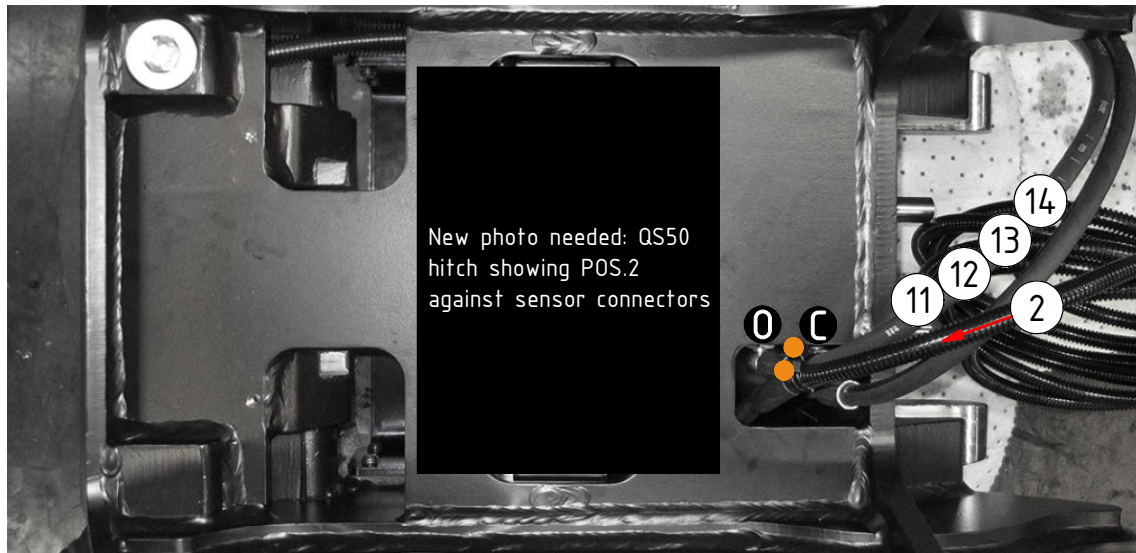

POS	DESCRIPTION	PART	QTY	COMMENTS
2	Cable QS - QLM - Quick hitch	842149	1	Attach to QS sensors
8	Rubber steel clamp ø10	6000003	2	QTY: 3 for QS50 ECO
11	Hose Lock	741505	2	
12	Hose Lock - Liebherr	7000560	2	
13	Hose Lock - Lännen	7000561	2	
14	Hose Lock - Huddig	7001484	2	
●	Use cable ties			

POS in order of assembly

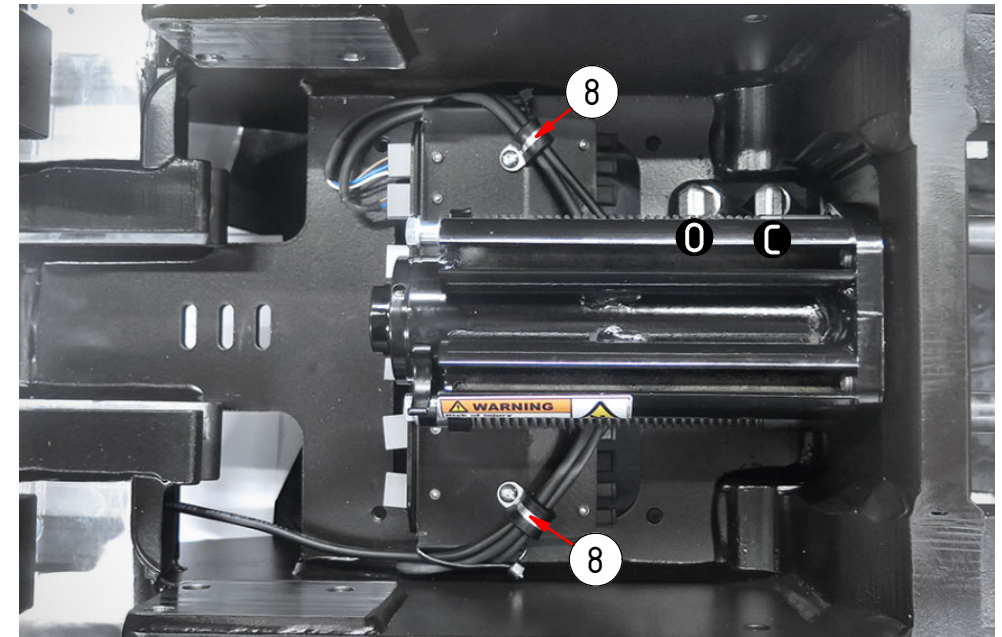

EC-Oil QS45
DC2 Std. config.

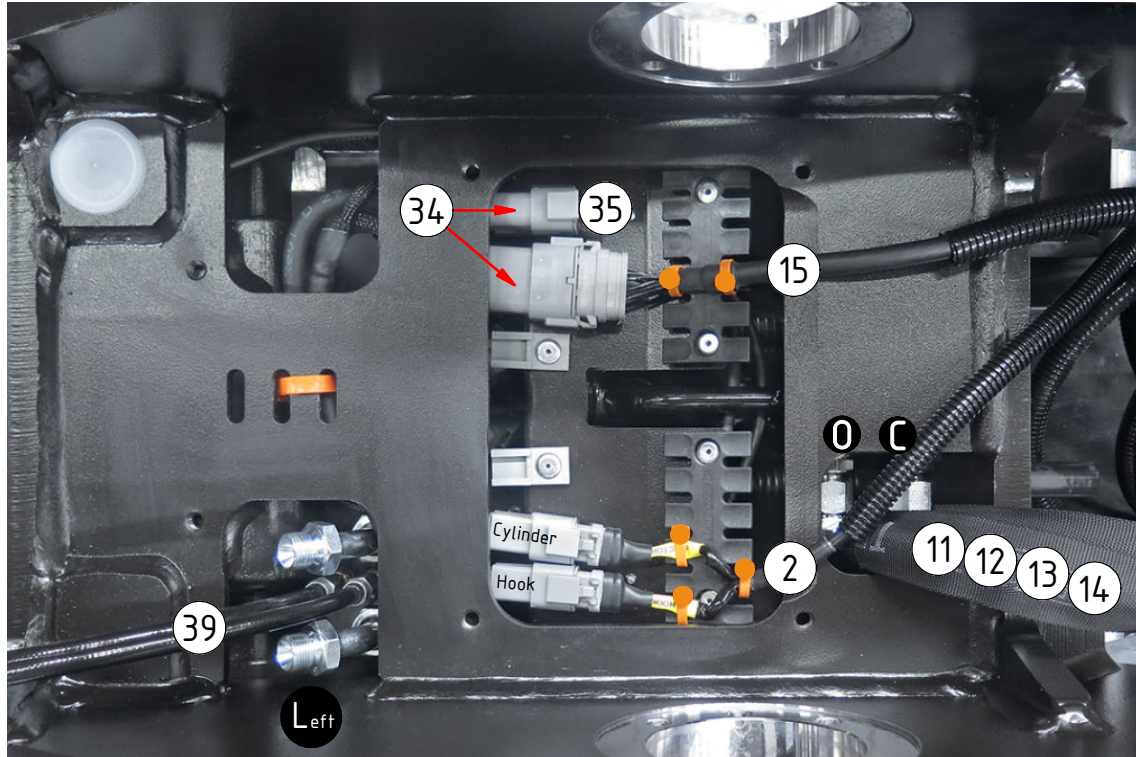

POS	DESCRIPTION	PART	QTY	COMMENTS
2	Cable QS - QLM - Quick hitch	842149	1	Attach to QS sensors
8	Rubber steel clamp \varnothing 10	6000003	2	QTY: 3 for QS50 ECO
11	Hose Lock	741505	2	
12	Hose Lock - Liebherr	7000560	2	
13	Hose Lock - Lannen	7000561	2	
14	Hose Lock - Huddig	7001484	2	
15	Machine cable ECO45/50 W DC2	1048527	1	Attach to 12P
34	Power plug ECO45 W Hitch	1042244	1	Cable gland torque: 6Nm
35	Plug for 6P	8000620	1	QTY depends on config.
39	Hose kit - lubricant ECO W	7000514	1	(POS.40-42 incl.)
●	Use cable ties			

POS in order of assembly

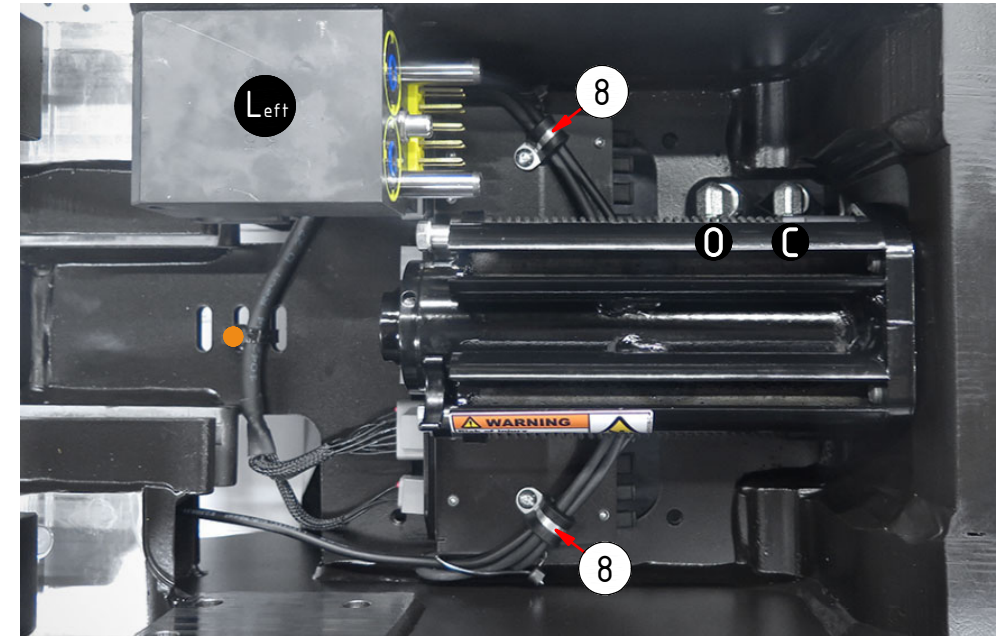

EC-Oil QS45
DC2 Option 2bl.

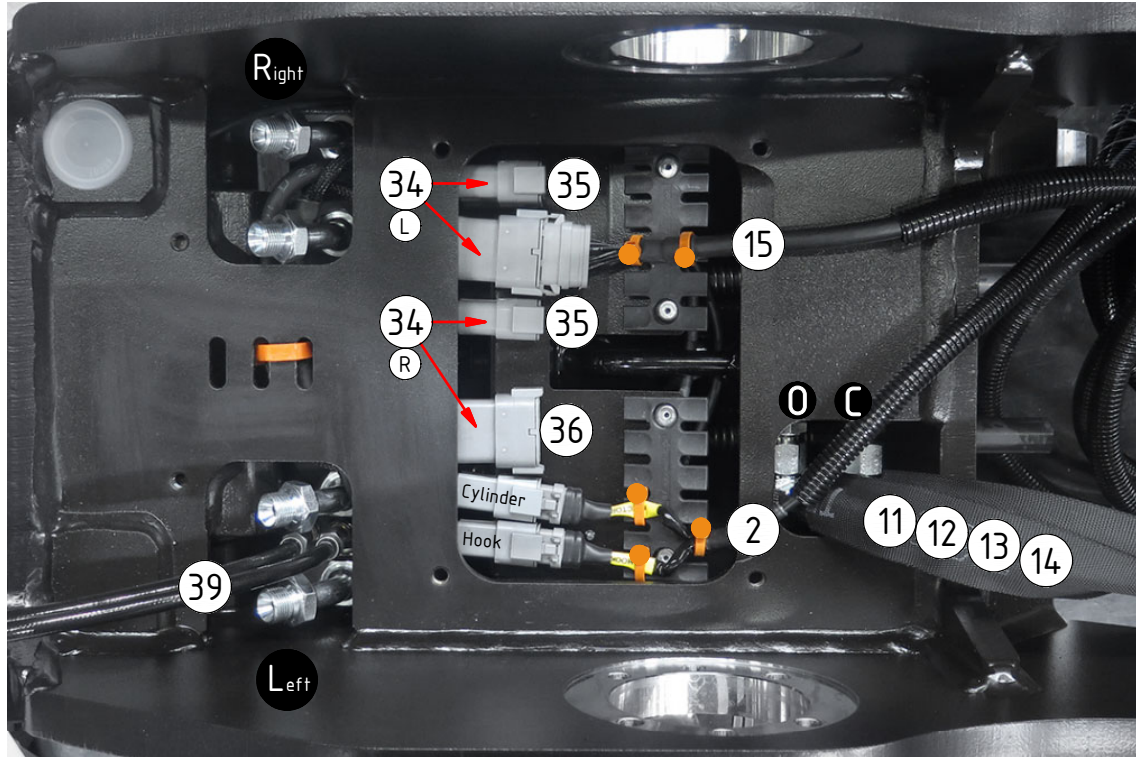

Option 5 hyd:

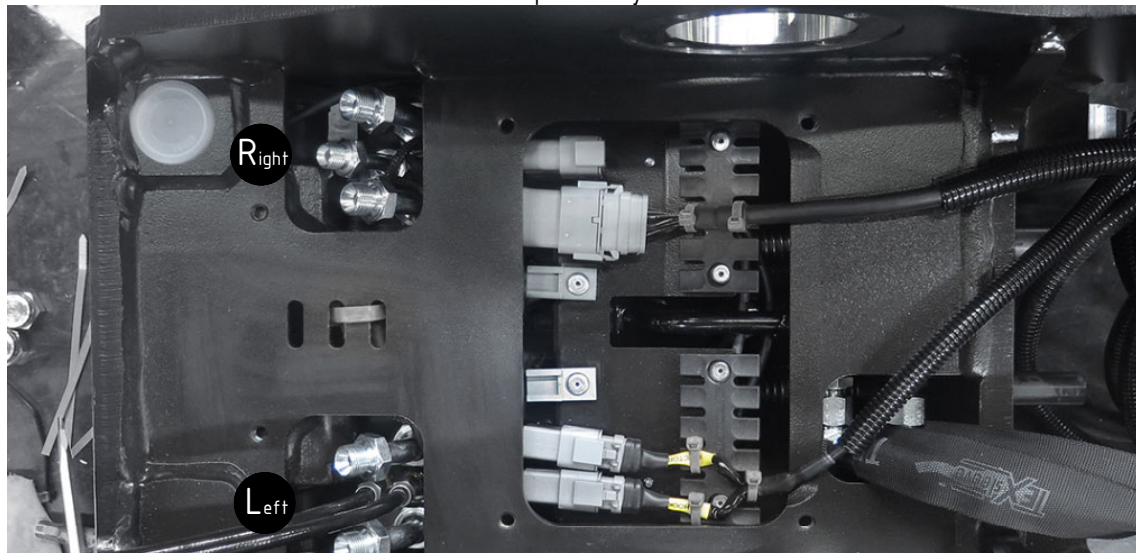

POS	DESCRIPTION	PART	QTY	COMMENTS
2	Cable QS - QLM - Quick hitch	842149	1	Attach to QS sensors
8	Rubber steel clamp $\varnothing 10$	6000003	2	QTY: 3 for QS50 ECO
11	Hose Lock	741505	2	
12	Hose Lock - Liebherr	7000560	2	
13	Hose Lock - Lännen	7000561	2	
14	Hose Lock - Huddig	7001484	2	
15	Machine cable ECO45/50 W DC2	1048527	1	Attach to Left 12P
34	Power plug ECO45 W Hitch	1042244	1	Cable gland torque: 6Nm
35	Plug for 6P	8000620	1	QTY depends on config.
36	Plug for 12P	8002058	1	QTY depends on config.
39	Hose kit - lubricant ECO W	7000514	1	(POS.40-42 incl.)
● Use cable ties				

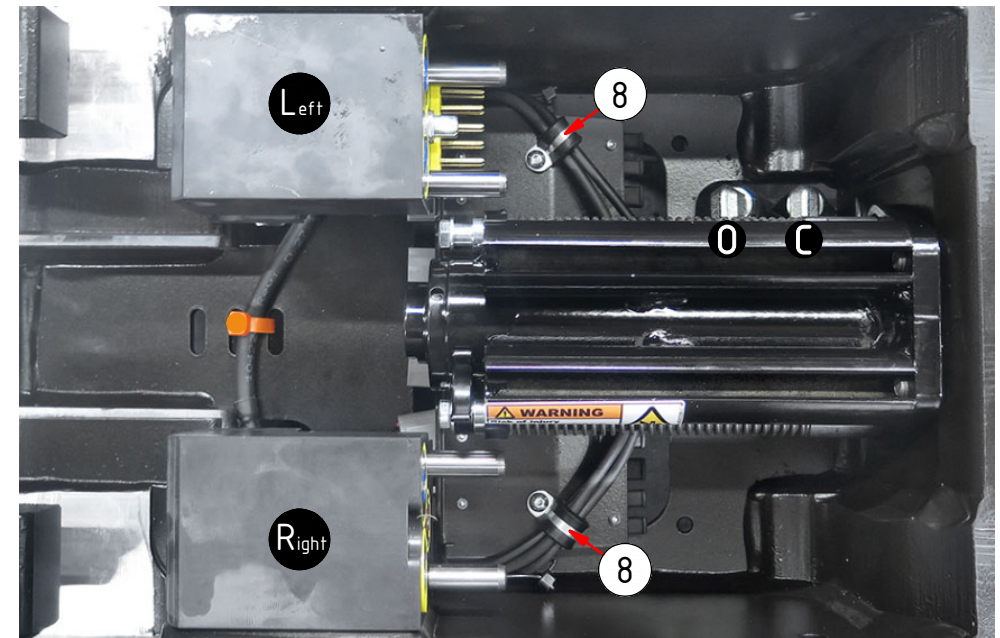

POS in order of assembly

EC-Oil QS45 ss9

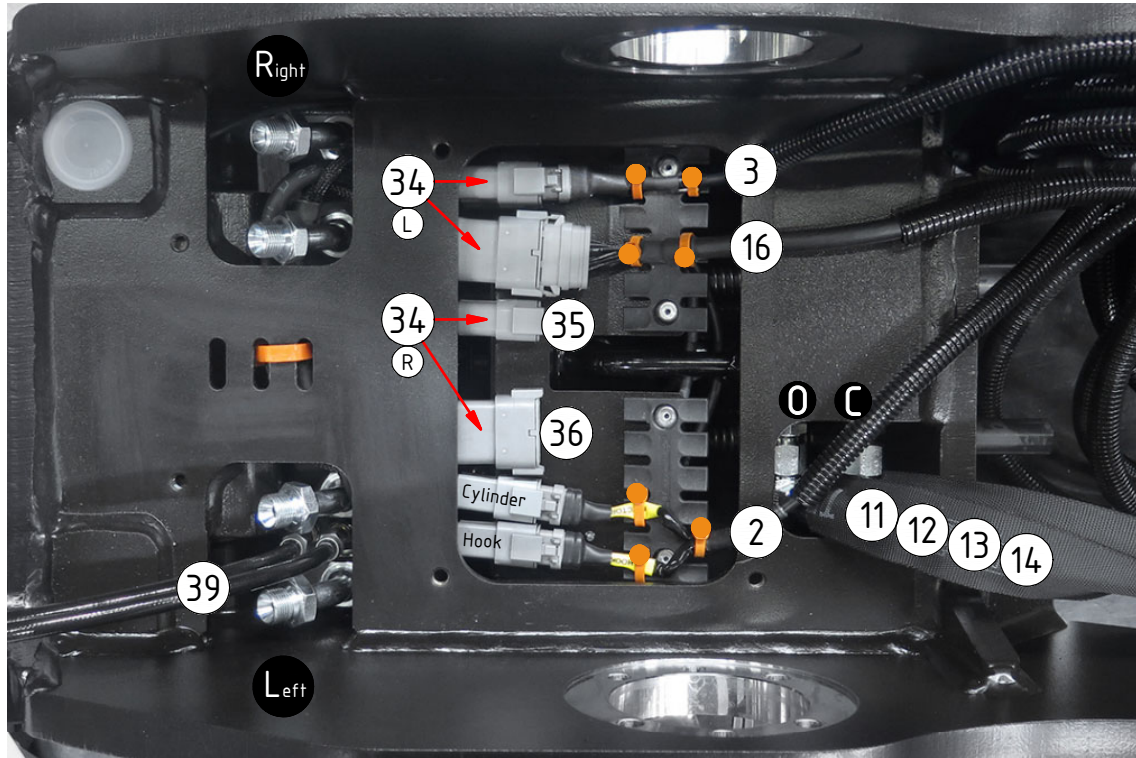

Option ePS:

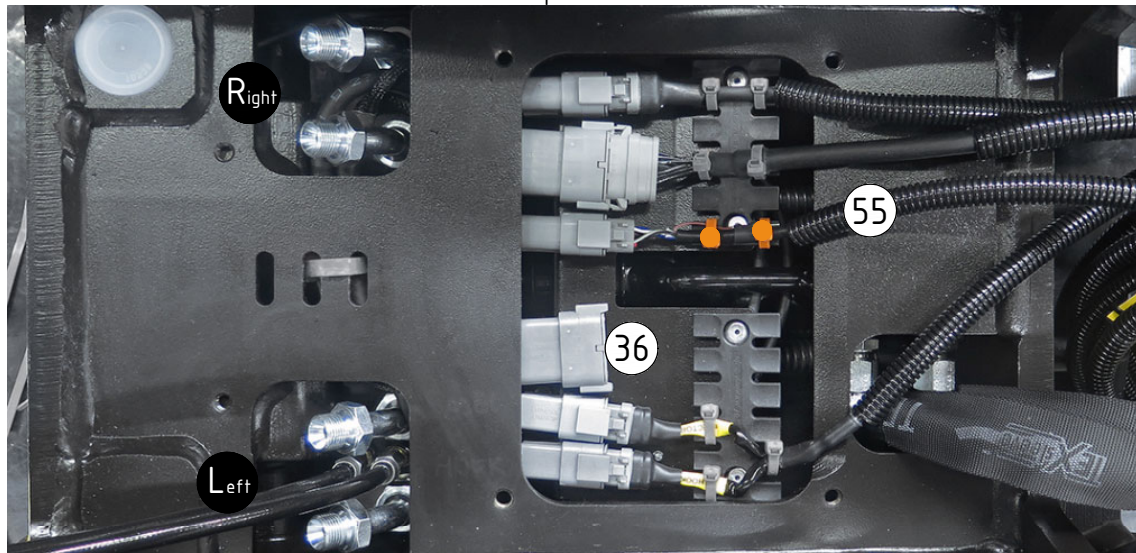

POS	DESCRIPTION	PART	QTY	COMMENTS
2	Cable QS - QLM - Quick hitch	842149	1	Attach to QS sensors
3	Cable QS - QLM - Tilt rotator	842148	1	Attach to Left 6P
8	Rubber steel clamp $\varnothing 10$	6000003	2	QTY: 3 for QS50 ECO
11	Hose Lock	741505	2	
12	Hose Lock - Liebherr	7000560	2	
13	Hose Lock - Lännen	7000561	2	
14	Hose Lock - Huddig	7001484	2	
16	Machinecable ECO W ss9-2 (1x 12P)	1036844	1	Attach to Left 12P
34	Power plug ECO45 W Hitch	1042244	1	Cable gland torque: 6Nm
35	Plug for 6P	8000620	1	QTY depends on config.
36	Plug for 12P	8002058	1	QTY depends on config.
39	Hose kit - lubricant ECO W	7000514	1	(POS.40-42 incl.)
55	Cable ePS ECO W ss9,ss10(SVAB)	1042246	1	Attach to Right 6P
● Use cable ties				

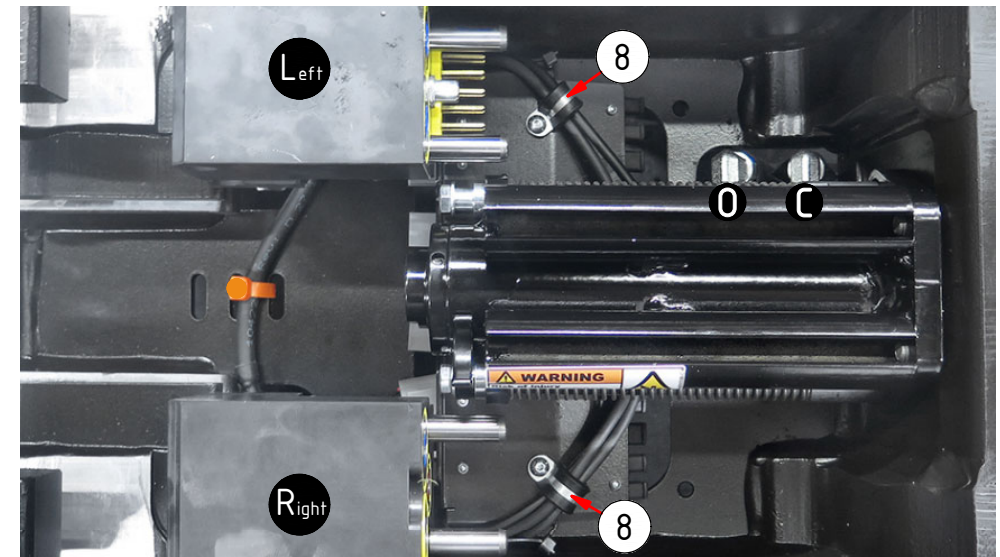

POS in order of assembly

EC-Oil QS45
ss10 (SVAB)

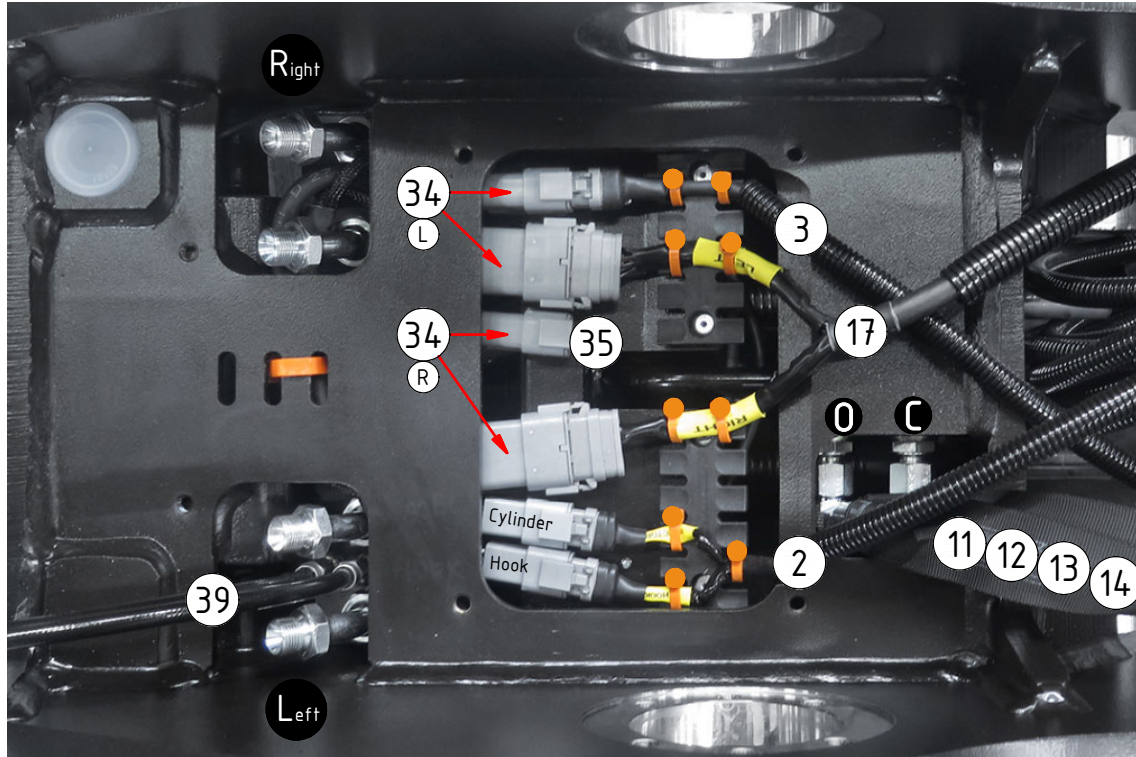

Option ePS:

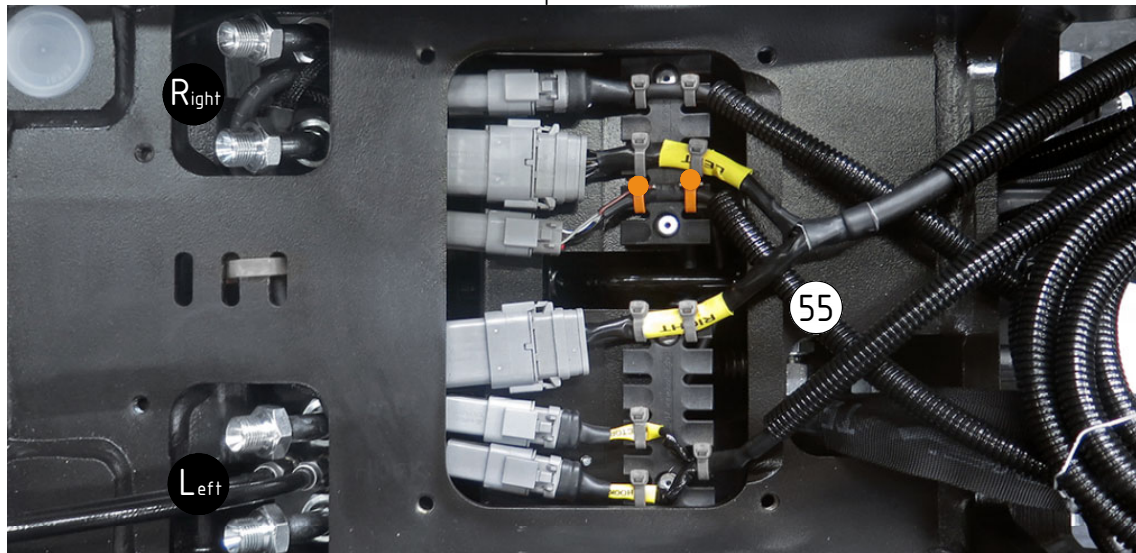

POS	DESCRIPTION	PART	QTY	COMMENTS
2	Cable QS - QLM - Quick hitch	842149	1	Attach to QS sensors
3	Cable QS - QLM - Tilt rotator	842148	1	Attach to Left 6P
8	Rubber steel clamp $\varnothing 10$	6000003	2	QTY: 3 for QS50 ECO
11	Hose Lock	741505	2	
12	Hose Lock - Liebherr	7000560	2	
13	Hose Lock - Lännen	7000561	2	
14	Hose Lock - Huddig	7001484	2	
17	Machinecable ECO W SVAB (2x 12P)	8002008	1	Attach to both 12P
34	Power plug ECO45 W Hitch	1042244	1	Cable gland torque: 6Nm
35	Plug for 6P	8000620	2	QTY depends on config.
39	Hose kit - lubricant ECO W	7000514	1	(POS.40-42 incl.)
55	Cable ePS ECO W ss9,ss10(SVAB)	1042246	1	Attach to Right 6P
● Use cable ties				

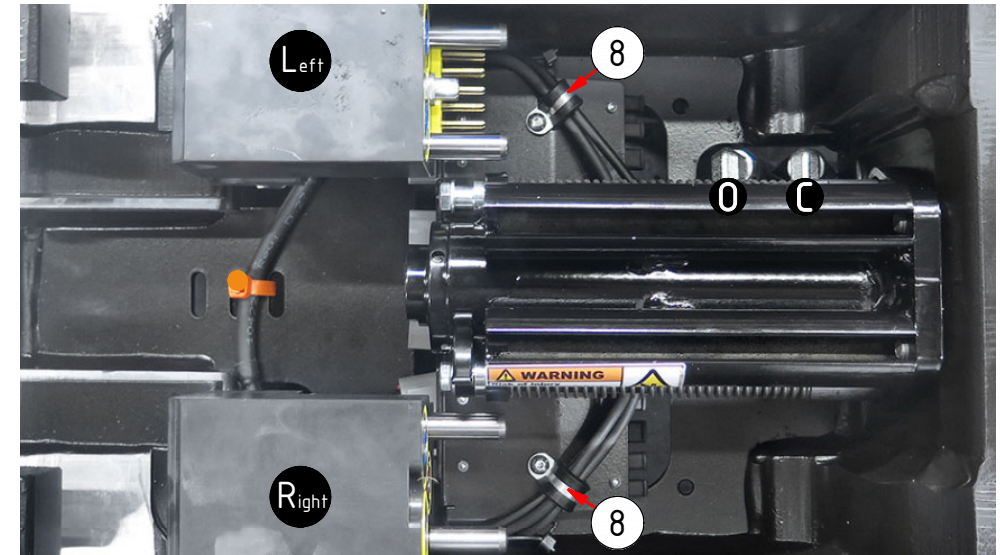

POS in order of assembly

EC-Oil QS50
DC2 Std. config.

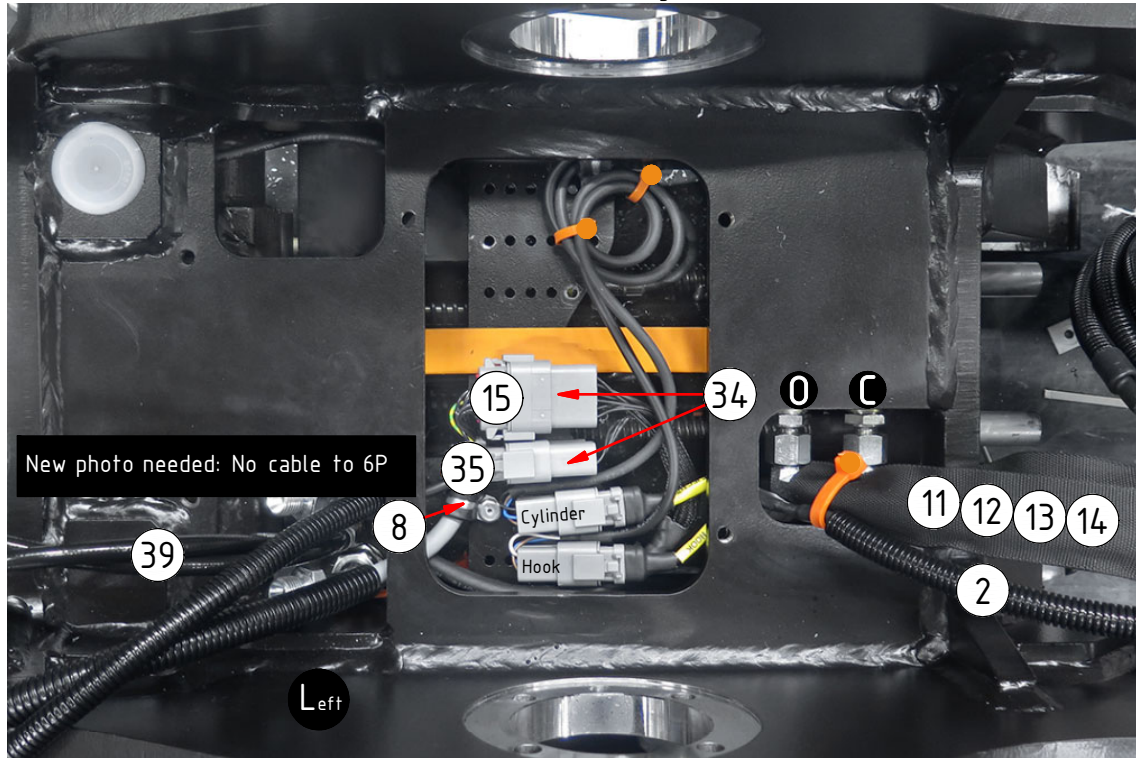

POS	DESCRIPTION	PART	QTY	COMMENTS
2	Cable QS - QLM - Quick hitch	842149	1	Attach to QS sensors
8	Rubber steel clamp $\varnothing 10$	6000003	2	QTY: 3 for QS50 ECO
11	Hose Lock	741505	2	
12	Hose Lock - Liebherr	7000560	2	
13	Hose Lock - Lännen	7000561	2	
14	Hose Lock - Huddig	7001484	2	
15	Machine cable ECO45/50 W DC2	1048527	1	Attach to 12P
34	Power plug ECO45 W Hitch	1042244	1	Cable gland torque: 6Nm
35	Plug for 6P	8000620	1	QTY depends on config.
39	Hose kit - lubricant ECO W	7000514	1	(POS.40-42 incl.)
●	Use cable ties			

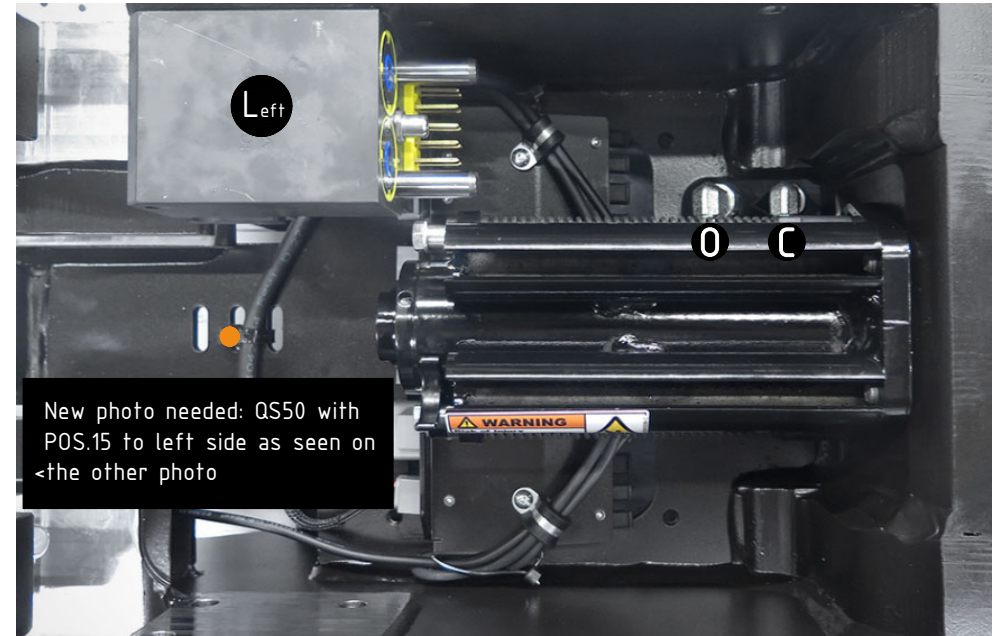

POS in order of assembly

EC-Oil QS50
DC2 Option 2bl.

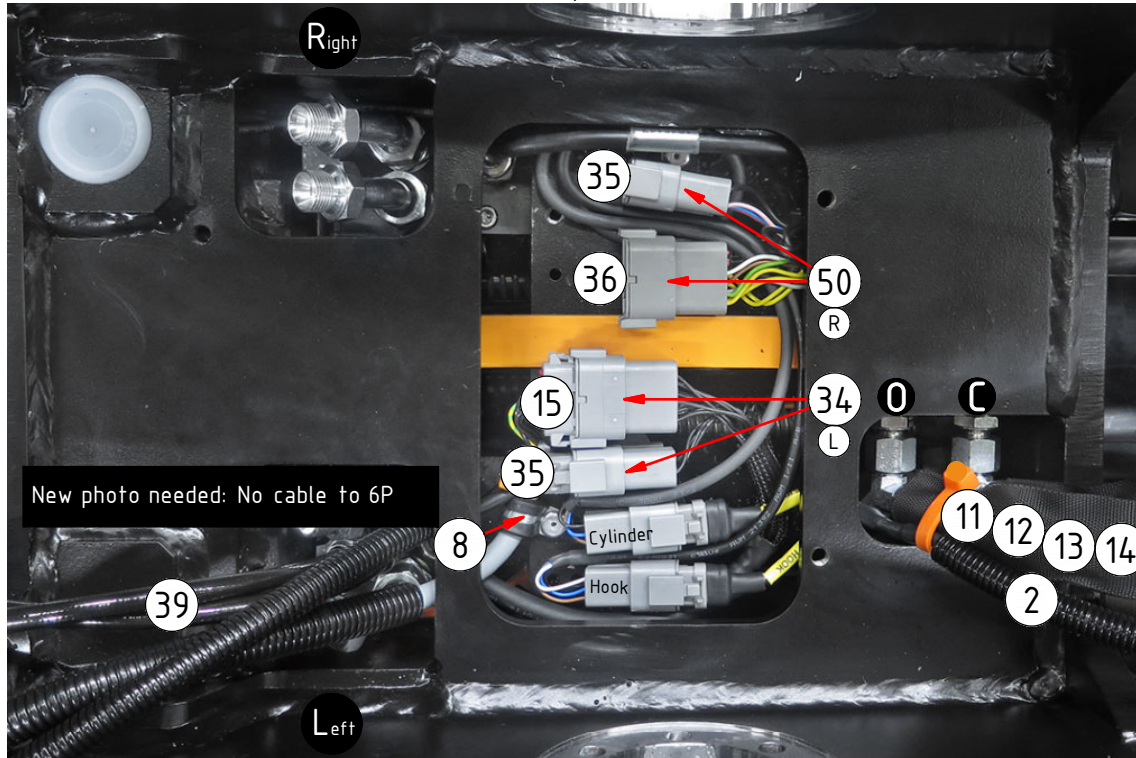

POS	DESCRIPTION	PART	QTY	COMMENTS
2	Cable QS - QLM - Quick hitch	842149	1	Attach to QS sensors
8	Rubber steel clamp \varnothing 10	6000003	2	QTY: 3 for QS50 ECO
11	Hose Lock	741505	2	
12	Hose Lock - Liebherr	7000560	2	
13	Hose Lock - Lannen	7000561	2	
14	Hose Lock - Huddig	7001484	2	
15	Machine cable ECO45/50 W DC2	1048527	1	Attach to Left 12P
34	Power plug ECO45 W Hitch	1042244	1	Cable gland torque: 6Nm
35	Plug for 6P	8000620	1	QTY depends on config.
36	Plug for 12P	8002058	1	QTY depends on config.
39	Hose kit - lubricant ECO W	7000514	1	(POS.40-42 incl.)
50	Power plug ECO50 W Hitch (QSM)	8002007	1	Cable gland torque: 6Nm
● Use cable ties				

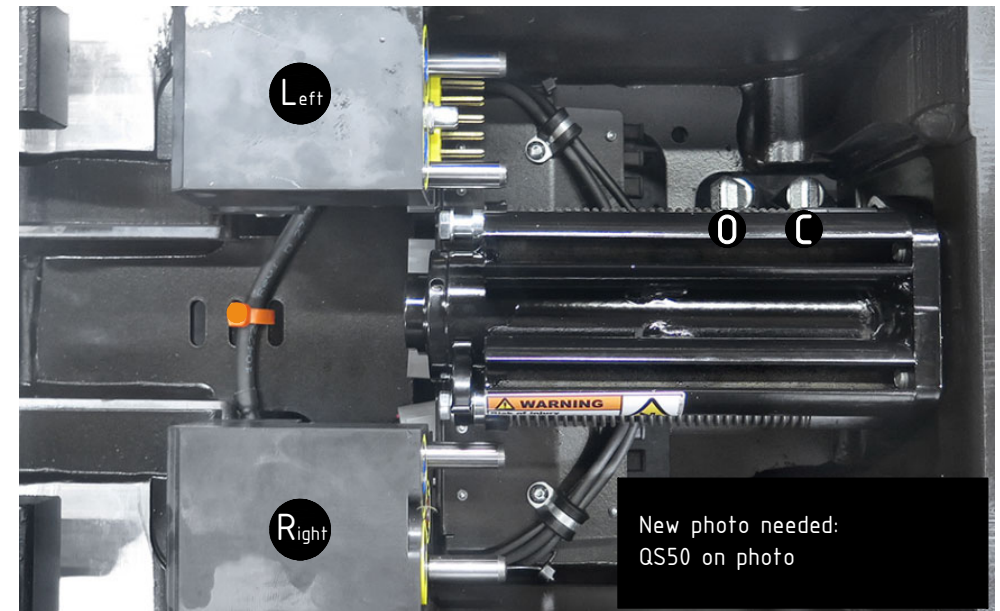

POS in order of assembly

EC-Oil QS50 ss9

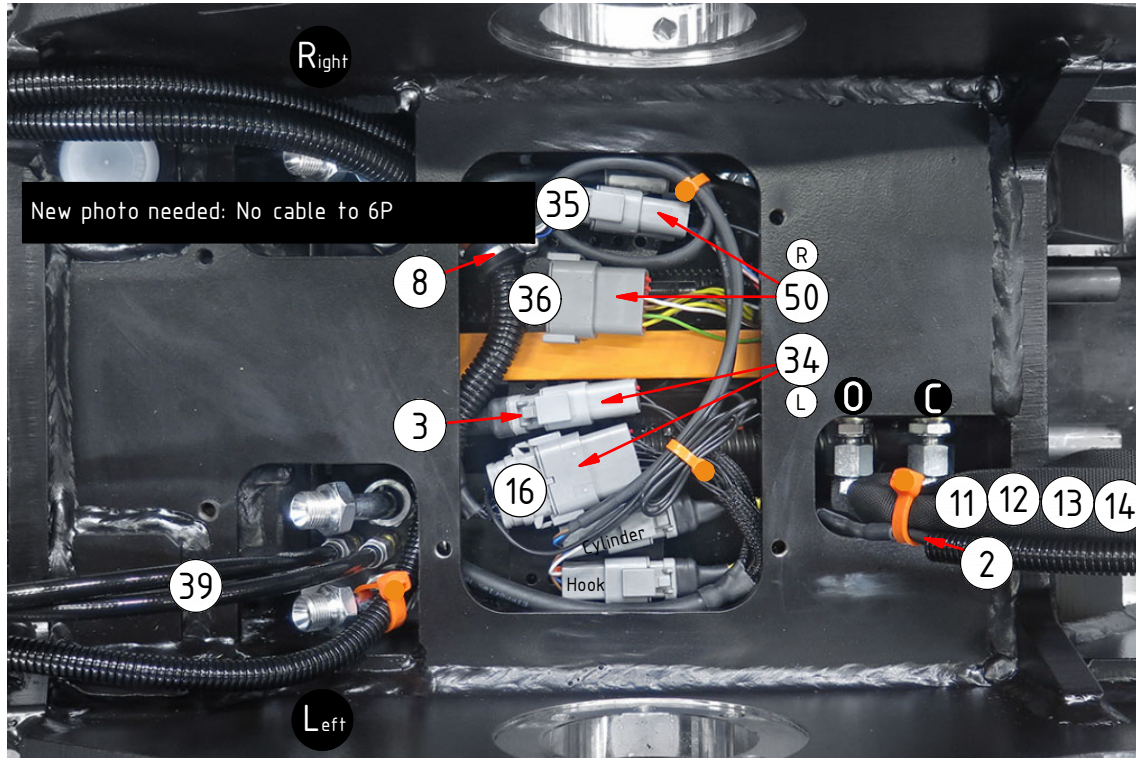

Option ePS:

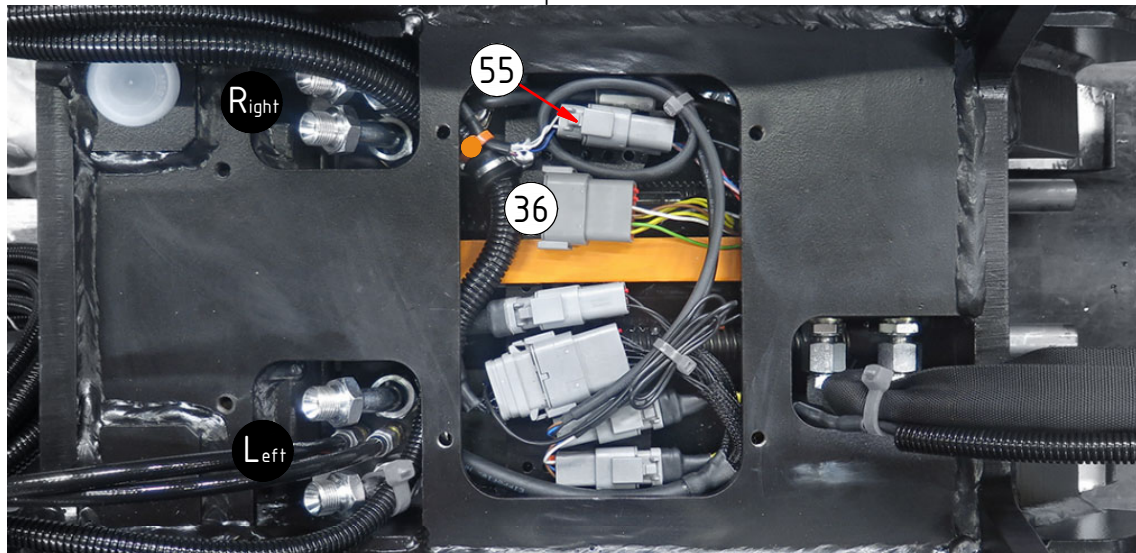

POS	DESCRIPTION	PART	QTY	COMMENTS
2	Cable QS - QLM - Quick hitch	842149	1	Attach to QS sensors
3	Cable QS - QLM - Tilt rotator	842148	1	Attach to Left 6P
8	Rubber steel clamp $\varnothing 10$	6000003	2	QTY: 3 for QS50 ECO
11	Hose Lock	741505	2	
12	Hose Lock - Liebherr	7000560	2	
13	Hose Lock - Lannen	7000561	2	
14	Hose Lock - Huddig	7001484	2	
16	Machinecable ECO W ss9-2 (1x 12P)	1036844	1	Attach to Left 12P
34	Power plug ECO45 W Hitch	1042244	1	Cable gland torque: 6Nm
35	Plug for 6P	8000620	1	QTY depends on config.
36	Plug for 12P	8002058	1	QTY depends on config.
39	Hose kit - lubricant ECO W	7000514	1	(POS.40-42 incl.)
50	Power plug ECO50 W Hitch (QSM)	8002007	1	Cable gland torque: 6Nm
55	Cable ePS ECO W ss9,ss10(SVAB)	1042246	1	Attach to Right 6P
	● Use cable ties			

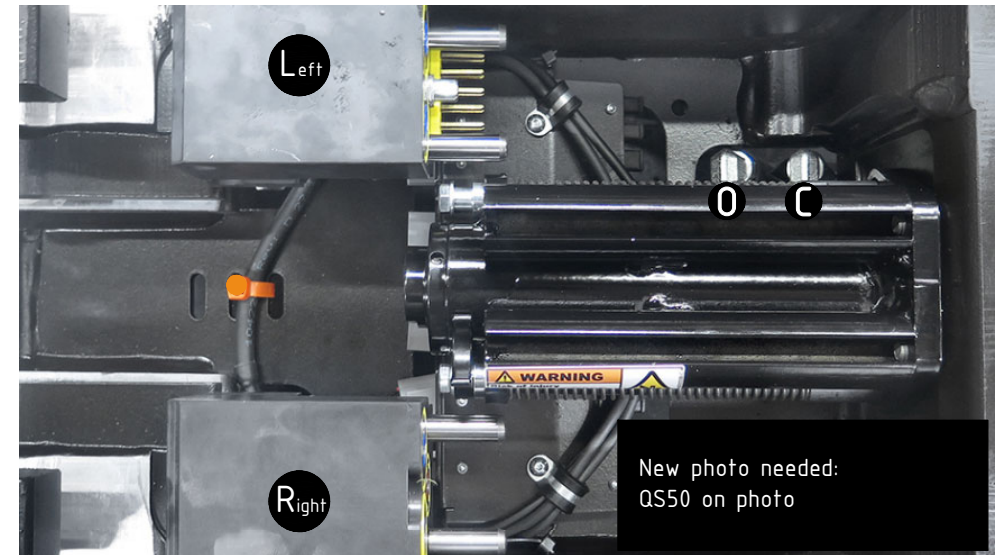

POS in order of assembly

EC-Oil QS50
ss10 (SVAB)

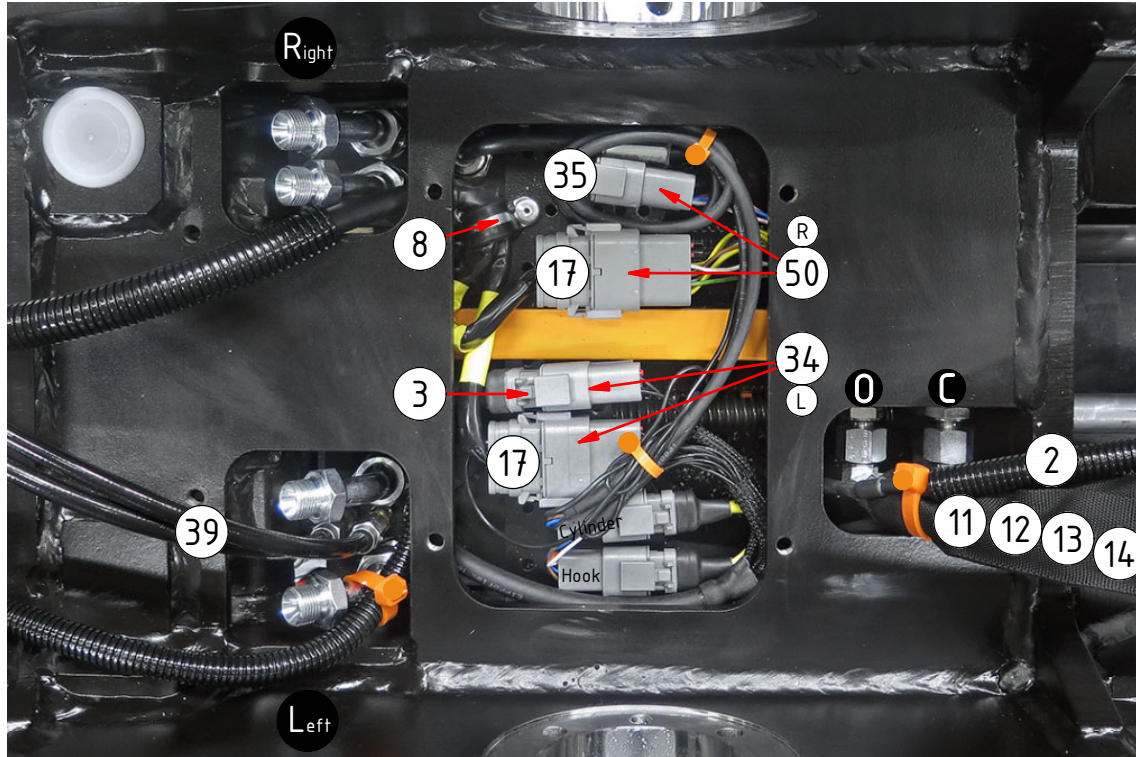

Option ePS:

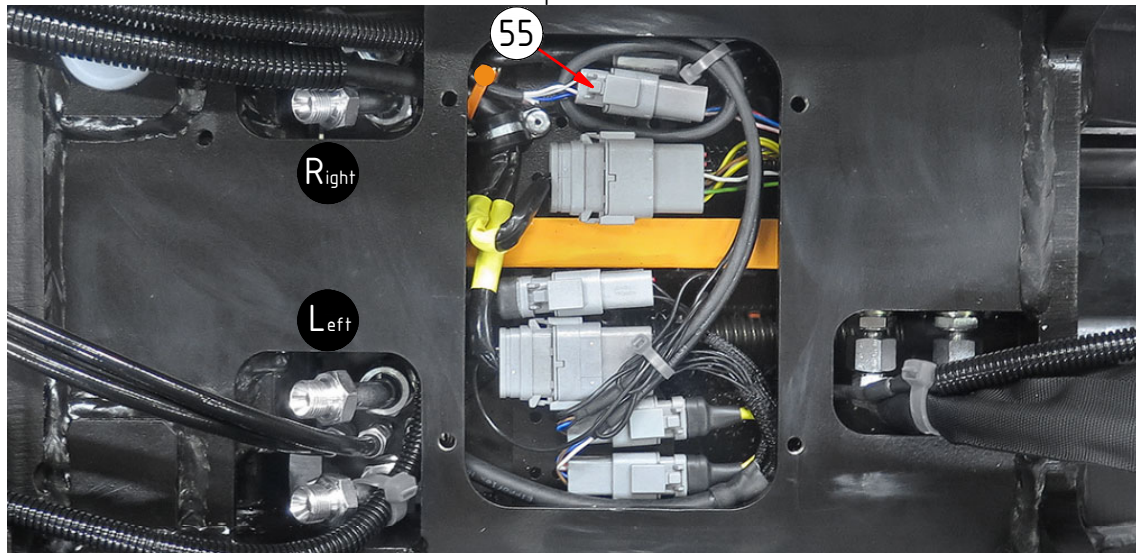

POS	DESCRIPTION	PART	QTY	COMMENTS
2	Cable QS - QLM - Quick hitch	842149	1	Attach to QS sensors
3	Cable QS - QLM - Tilt rotator	842148	1	Attach to Left 6P
8	Rubber steel clamp $\varnothing 10$	6000003	2	QTY: 3 for QS50 ECO
11	Hose Lock	741505	2	
12	Hose Lock - Liebherr	7000560	2	
13	Hose Lock - Lännen	7000561	2	
14	Hose Lock - Huddig	7001484	2	
17	Machinecable ECO W SVAB (2x 12P)	8002008	1	Attach to both 12P
34	Power plug ECO45 W Hitch	1042244	1	Cable gland torque: 6Nm
35	Plug for 6P	8000620	1	QTY depends on config.
39	Hose kit - lubricant ECO W	7000514	1	(POS.40-42 incl.)
50	Power plug ECO50 W Hitch (QSM)	8002007	1	Cable gland torque: 6Nm
55	Cable ePS ECO W ss9,ss10(SVAB)	1042246	1	Attach to Right 6P
● Use cable ties				

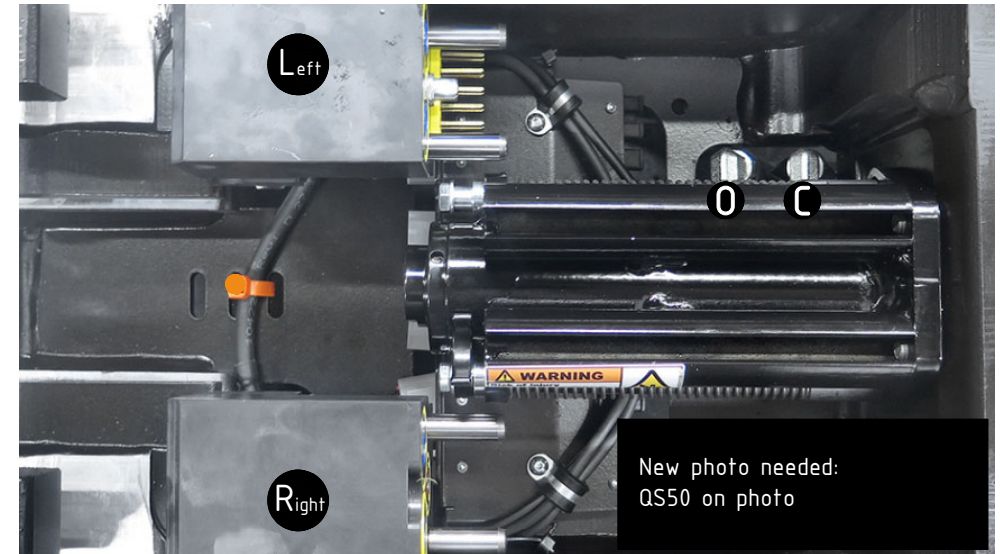

POS in order of assembly

SPARE PARTS

ECO50
w/o el.

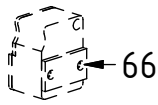

w/o el.

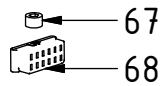

w/o hyd.

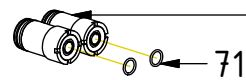
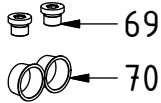

1025586

O-rings between versions are not compatible

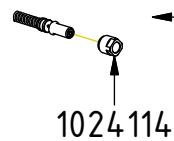

1042362

Replaced by POS.23 from 2019-01. On ECO blocks previous rev E: remove o-ring on nut

QS45: Replaced by POS.57 from 2019-10

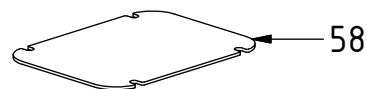

POS	DESCRIPTION	PART	QTY	COMMENTS
15	Machine cable ECO45/50 W DC2	1048527	1	Attach to 12P
17	Machinecable ECO W SVAB (2x 12P)	8002008	1	Attach to both 12P
20	Coupling ECO W 3/8" V3	1053029	2	Torque: 60Nm. (POS.21 incl.)
21	Flat sealing for ECO W 3/8" V3	1052976	2	
23	Lubrication kit ECO W	1050794	1	(POS.24-30 incl.)
50	Power plug ECO50 W Hitch (QSM)	8002007	1	Cable gland torque: 6Nm
57	Cover QS45 V3	1053624	1	
58	Cover QS45/QS50	1025581	1	Only for QS50 from 2019-10
64	Machinecable ECO W SVAB (2x 12P)	1029500	1	Replaced by POS.17 from 2023-06
65	Power plug ECO50 W Hitch (QS/QSD)	1045167	1	Replaced by POS.50 from 2023-06 Not compatible with QSM
66	Transport Protection ECO50 w/o el.	1049168	1	Part of make up
67	Pipe plug DIN 906 M16x1,5	711529	1	
68	Plug ECO W - Hitch	1041814	1	
69	Plug 70125-06 (3/8")	711504	2	
70	Protection plug ECO45/50 hydraulic	7000153	2	
71	O-ring 12,42x1,78 PU - ECO45 3/8"	712417	2	Used until 2020-03 Separate seal kit: 7000045
72	Cable ECO Tiltangle sensor DC2 ePS	1049315	1	Used on 6P (DC2 ePS) until 2022-11
73	Cable ECO W Tiltanglesensor ss9-2	1047113	1	Attach to Right 12P
74	Cable ECO W Tiltanglesensor SVAB	1047111	1	L.BI: WH>11. R.BI: BR>1, BL>2, GR>11
75	Machine cable ECO45/50 W DC2 two connectors	1042247	1	Replaced by POS.15 from 2018-08 Attach to 6P and 12P
76	Machine cable ECO45/50 W MACS	1043276	1	Attach to 12P

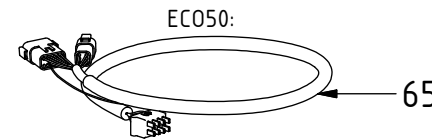

ePS1:

