

COVERSHEET

Planned document changes:

Briefly:

 No planned changes.

Document changes:

Date:	Change:	Rev. after change:
2024-03-05	DC3 added.	O
2023-05-04	QSM50 right block power plug added.	N
2023-01-18	New std. configurations from 2023.	M
2022-08-25	Torques added.	L
2021-12-07	Details for block with 3hyd. updated.	K
2021-11-10	Details for block with 3hyd. added.	J
2021-09-29	c.l lengths and adapters updated. Power plugs updated.	I
2021-01-28	Transport protection added.	H
2019-10-28	Adapters for Top bracket QS50 updated.	G
2019-10-04	Adapters for Top bracket updated.	F
2019-03-22	Torques added.	E
2018-12-17	Plugs for Top bracket added.	D
2018-11-09	Layout/irrelevant.	C
2018-07-11	Hose kit updated.	B
2018-06-21	Layout/irrelevant.	A
2018-04-11	New document.	-

Readers note:
 Indicates instruction.

 Represents Hose.

Dashed lines for overview, mounts
on other pages/assemblies.

QS45
DC3

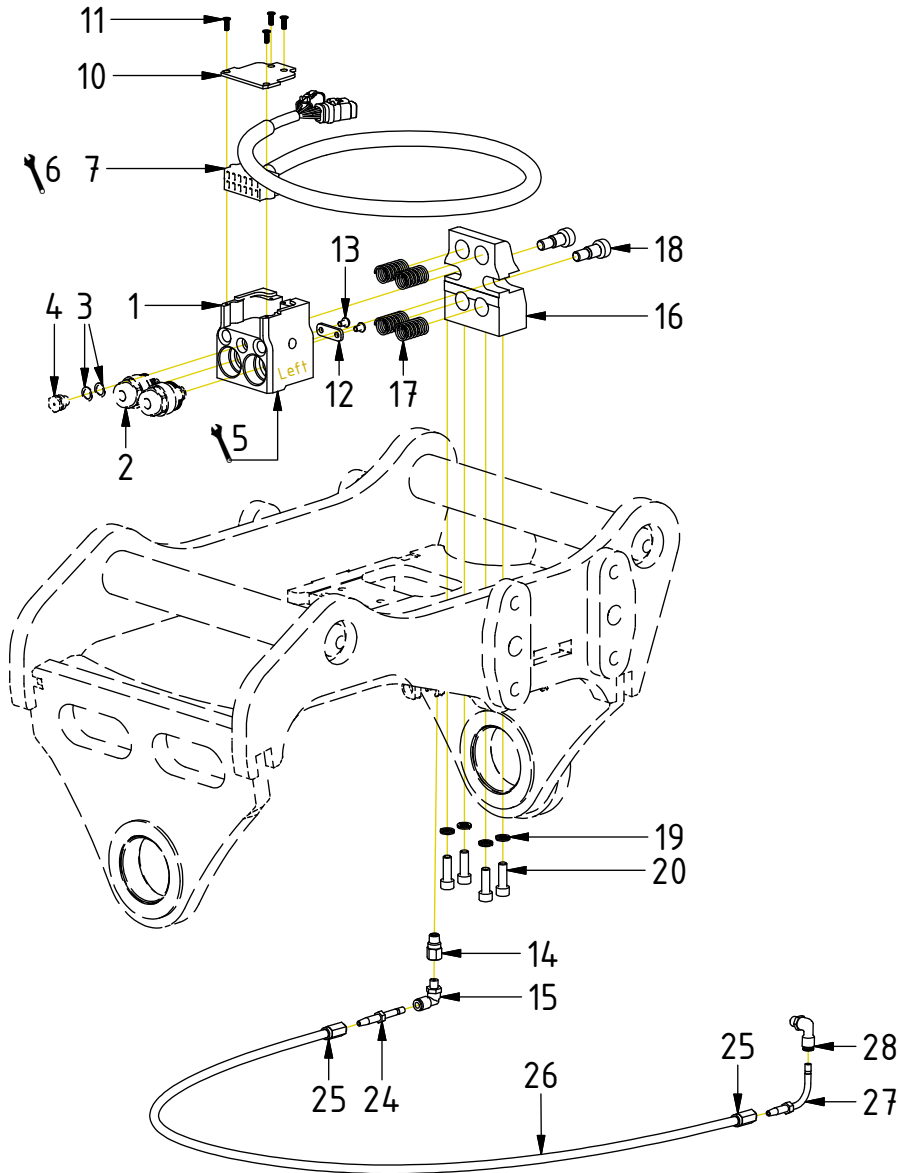

POS	DESCRIPTION	PART	QTY	COMMENTS
1	Block ECO45W Top 2hy.1cl. Complete	1074024	1	
2	Coupling ECO45/50 3/8" male	1028873	2	Torque: 60Nm
3	Washer Copper 14x10	6000065	2	
4	Button head fitting 1/8" stainless	810505	1	Loxeal 58-12. Torque: 30Nm
5	Adapters according to Top part			See "Top part"
6	Power plug cable gland torque: 6Nm			
7	Power plug ECO45 W Top (4S, 6S)	8002244	1	
10	Coverplate ECO45 W Top	1041099	1	
11	Screw MKFT 4x12	6000121	4	
12	Cable clamp	1074897	1	
13	Screw K6S M5x8 10.9 FZB	611801	2	
14	Extender M8x1-M8x1 18mm	7000688	1	Loxeal 58-12
15	Push-in swivel 90° M8x1	790173	1	Loxeal 58-12
16	Attachment block ECO45 W Top	1041097	1	
17	Spring 18x35	1024794	4	
18	Shoulder bolt ø12x16/M10	611708	2	Loxeal 83-52
19	Washer NL 8mm	611040	4	
20	Screw MC6S M8x25 12.9 ZFSL	6000143	4	Torque: 40Nm
24	Pipe stub straight Push-in	790175	1	
25	Screw socket HT-hose	7000585	2	
26	Grease hose bulk 100m	7001303	1	EC209B: 845mm
27	Pipe stub 90° Push-in	7000318	1	
28	Adapter 90° Push-in - R1/8"	790184	1	Loxeal 58-12
57	Transport Protection ECO-Block	1035199	1	Part of make up

POS in order of assembly

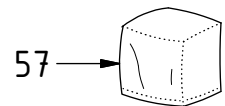

QS45/50
DC2 Std. config.

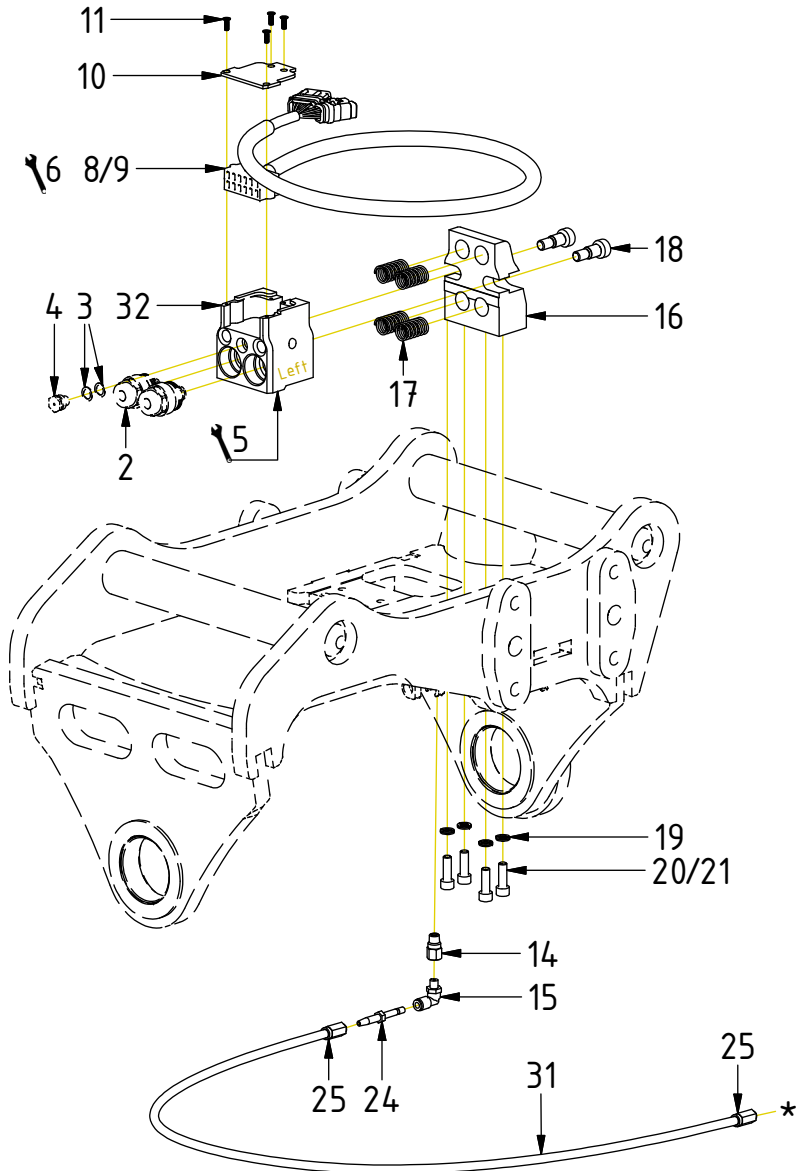

POS	DESCRIPTION	PART	QTY	COMMENTS
2	Coupling ECO45/50 3/8" male	1028873	2	Torque: 60Nm
3	Washer Copper 14x10	6000065	2	
4	Button head fitting 1/8" stainless	810505	1	Loxéal 58-12. Torque: 30Nm
5	Adapters according to Top part			See "Top part"
6	Power plug cable gland torque: 6Nm			
8	Power Plug ECO W - ECHF, QSM	8001089	1	For EC214, EC209B
9	Power Plug ECO W	1042241	1	For EC206, EC209, Top bracket
10	Coverplate ECO45 W Top	1041099	1	
11	Screw MKFT 4x12	6000121	4	
14	Extender M8x1-M8x1 18mm	7000688	1	Loxéal 58-12
15	Push-in swivel 90° M8x1	790173	1	Loxéal 58-12
16	Attachment block ECO45 W Top	1041097	1	
17	Spring 18x35	1024794	4	
18	Shoulder bolt ø12x16/M10	611708	2	Loxéal 83-52
19	Washer NL 8mm	611040	4	
20	Screw MC6S M8x25 12.9 ZFSHL	6000143	4	Torque: 40Nm
21	K6S 8x25 10.9 untreated	611814	4	For EC209 (6-ch). Torque: 34Nm
24	Pipe stub straight Push-in	790175	1	
25	Screw socket HT-hose	7000585	2	
27	Pipe stub 90° Push-in	7000318	1	
28	Adapter 90° Push-in - R1/8"	790184	1	Loxéal 58-12
29	Push-in R1/8"	790172	1	Loxéal 58-12
30	Extender 25/17mm KR1/8"-R1/8"	7000578	1	Loxéal 58-12
31	Grease hose bulk 100m	7001303	1	EC214: 1075mm EC209B: 845mm. EC209: 750mm EC206: 385mm
32	Block ECO45/50W Top 2hy.1cl. Compl.	1048023	1	(POS.2-4 incl.)
57	Transport Protection ECO-Block	1035199	1	Part of make up

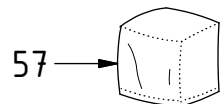
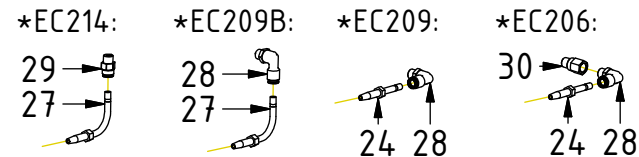

POS in order of assembly

QS45
DC2 Option 2bl.

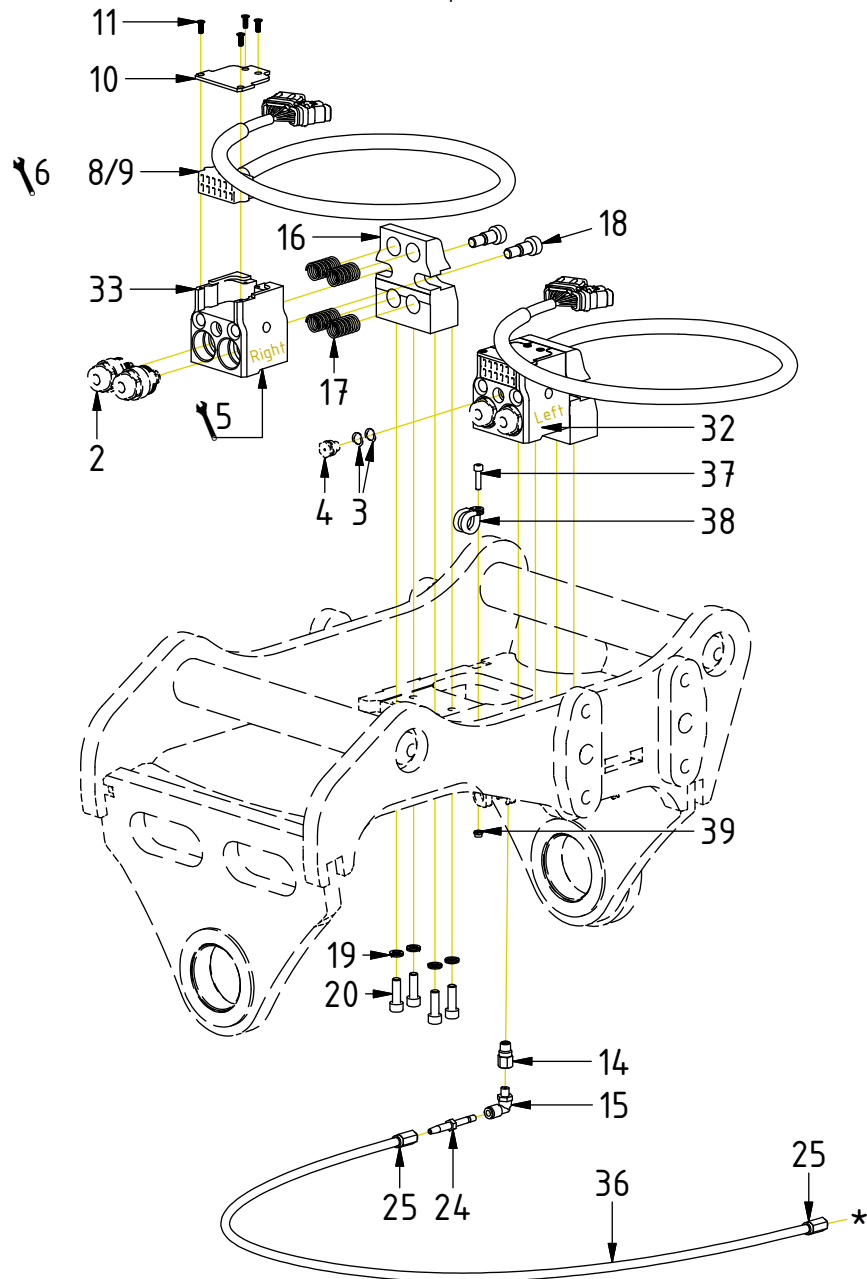

POS	DESCRIPTION	PART	QTY	COMMENTS
2	Coupling ECO45/50 3/8" male	1028873	2	Torque: 60Nm
3	Washer Copper 14x10	6000065	2	
4	Button head fitting 1/8" stainless	810505	1	Loxéal 58-12. Torque: 30Nm
5	Adapters according to Top part			See "Top part"
6	Power plug cable gland torque: 6Nm			
8	Power Plug ECO W - ECHF, QSM	8001089	1	For EC214, EC209B
9	Power Plug ECO W	1042241	1	For EC206, EC209, Top bracket
10	Coverplate ECO45 W Top	1041099	1	
11	Screw MKFT 4x12	6000121	4	
14	Extender M8x1-M8x1 18mm	7000688	1	Loxéal 58-12
15	Push-in swivel 90° M8x1	790173	1	Loxéal 58-12
16	Attachment block ECO45 W Top	1041097	1	
17	Spring 18x35	1024794	4	
18	Shoulder bolt \varnothing 12x16/M10	611708	2	Loxéal 83-52
19	Washer NL 8mm	611040	4	
20	Screw MC6S M8x25 12.9 ZFSHL	6000143	4	Torque: 40Nm
24	Pipe stub straight Push-in	790175	1	
25	Screw socket HT-hose	7000585	2	
27	Pipe stub 90° Push-in	7000318	1	
28	Adapter 90° Push-in - R1/8"	790184	1	Loxéal 58-12
29	Push-in R1/8"	790172	1	Loxéal 58-12
30	Extender 25/17mm KR1/8"-R1/8"	7000578	1	Loxéal 58-12
32	Block ECO45/50W Top 2hy.1cl. Compl.	1048023	1	(POS.2-4 incl.)
33	Block ECO45/50W Top 2hy. Complete	1048025	1	(POS.3-4 incl.)
34	Block ECO45 W Top 3hy. Complete	1054418	1	(POS.2, 35 incl.)
35	Coupling ECO 1/4" male	1053693	1	
36	Grease hose bulk 100m	7001303	1	EC214: 1075mm, EC209B: 845mm EC206: 385mm
37	Screw MC6S M5x20 12.9	610400	1	
38	Rubber steel clamp \varnothing 16	6000009	1	Face downwards
39	Lock Nut M6M M5x0,8 8,8 FZB	610920	1	
57	Transport Protection ECO-Block	1035199	1	Part of make up

Option 5 hyd:

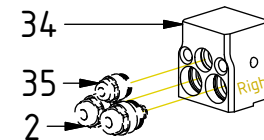

*EC214:

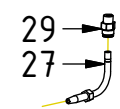

*EC209B:

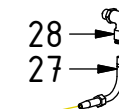

*EC206:

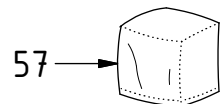
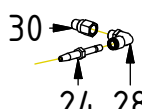

POS in order of assembly

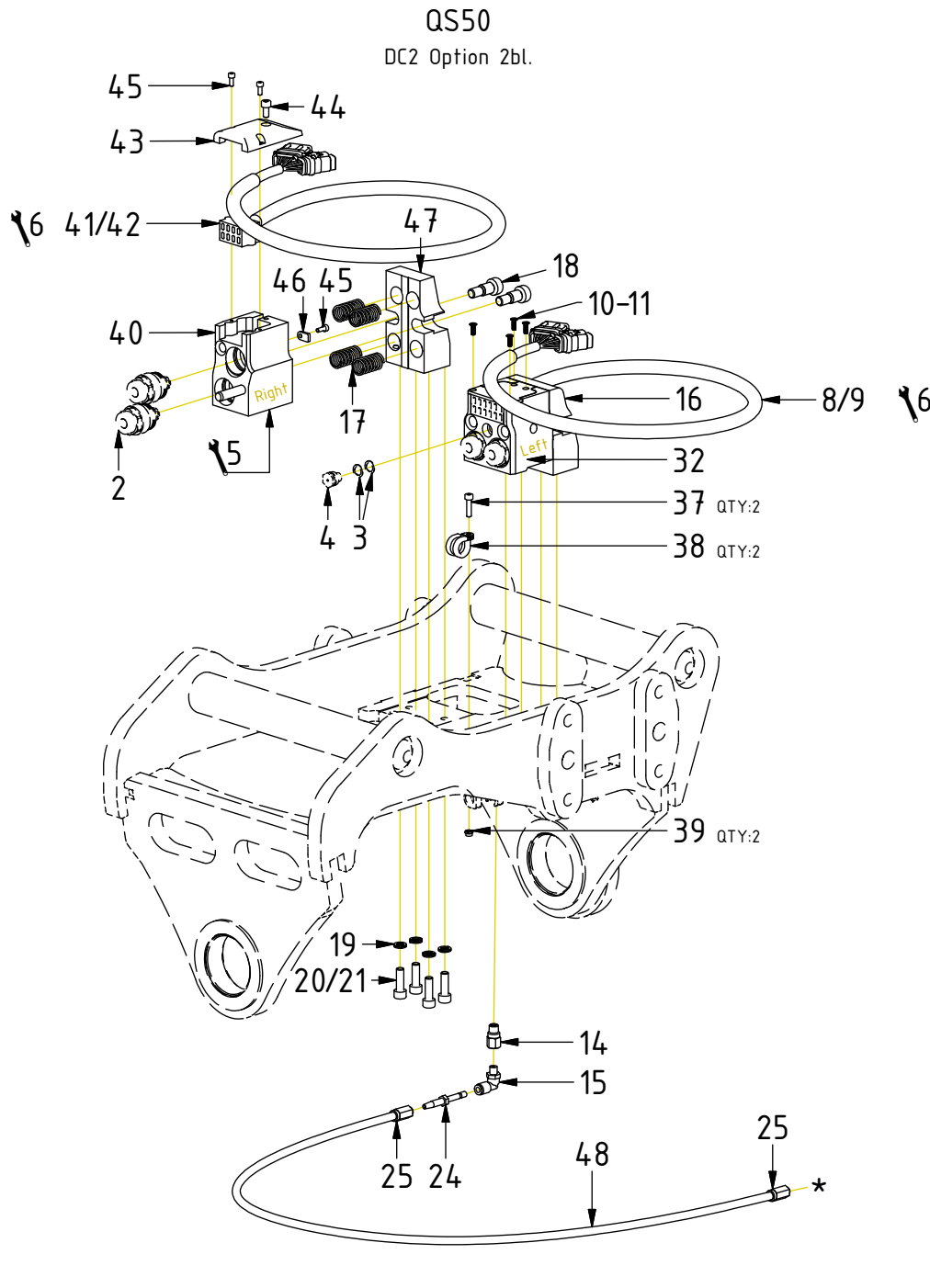

POS	DESCRIPTION	PART	QTY	COMMENTS
2	Coupling ECO45/50 3/8" male	1028873	2	Torque: 60Nm
3	Washer Copper 14x10	6000065	2	
4	Button head fitting 1/8" stainless	810505	1	Loxéal 58-12. Torque: 30Nm
5	Adapters according to Top part			See "Top part"
6	Power plug cable gland torque: 6Nm			
8	Power Plug ECO W - ECHF, QSM	8001089	1	For EC214, EC209B
9	Power Plug ECO W	1042241	1	For EC206, EC209, Top bracket
10	Coverplate ECO45 W Top	1041099	1	
11	Screw MKFT 4x12	6000121	4	
14	Extender M8x1-M8x1 18mm	7000688	1	Loxéal 58-12
15	Push-in swivel 90° M8x1	790173	1	Loxéal 58-12
16	Attachment block ECO45 W Top	1041097	1	
17	Spring 18x35	1024794	4	
18	Shoulder bolt \varnothing 12x16/M10	611708	2	Loxéal 83-52
19	Washer NL 8mm	611040	4	
20	Screw MC6S M8x25 12.9 ZFSHL	6000143	4	Torque: 40Nm
21	K6S 8x25 10.9 untreated	611814	4	For EC209 (6-ch). Torque: 34Nm
24	Pipe stub straight Push-in	790175	1	
25	Screw socket HT-hose	7000585	2	
27	Pipe stub 90° Push-in	7000318	1	
28	Adapter 90° Push-in - R1/8"	790184	1	Loxéal 58-12
32	Block ECO45/50W Top 2hy.1cl. Compl.	1048023	1	(POS.2-4 incl.)
37	Screw MC6S M5x20 12.9	610400	1	
38	Rubber steel clamp \varnothing 16	6000009	1	Face downwards
39	Lock Nut M6M M5x0,8 8,8 FZB	610920	1	
40	Block ECO50 W Top 2hy. Complete	1048074	1	(POS.2 incl.)
41	Power Plug ECO50 W - QSM w. 1x DTM042P	8002006	1	For EC209B
42	Power Plug ECO50 W	1045168	1	
43	Coverplate ECO50 W Top	1041646	1	
44	Screw MC6S M6x12 12.9	610412	1	Loxéal 55-02
45	Screw MC6S M4x10 8,8 FZB	610523	3	Loxéal 55-02
46	Clamping washer	1045180	1	
47	Supportblock ECO50 W right	1041645	1	
48	Grease hose bulk 100m	7001303	1	EC209B: 845mm. EC209: 750mm
57	Transport Protection ECO-Block	1035199	1	Part of make up

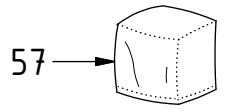
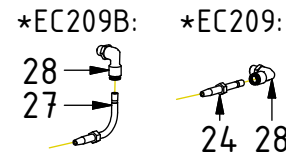

POS in order of assembly

QS45

ss9 & ss10 (SVAB)

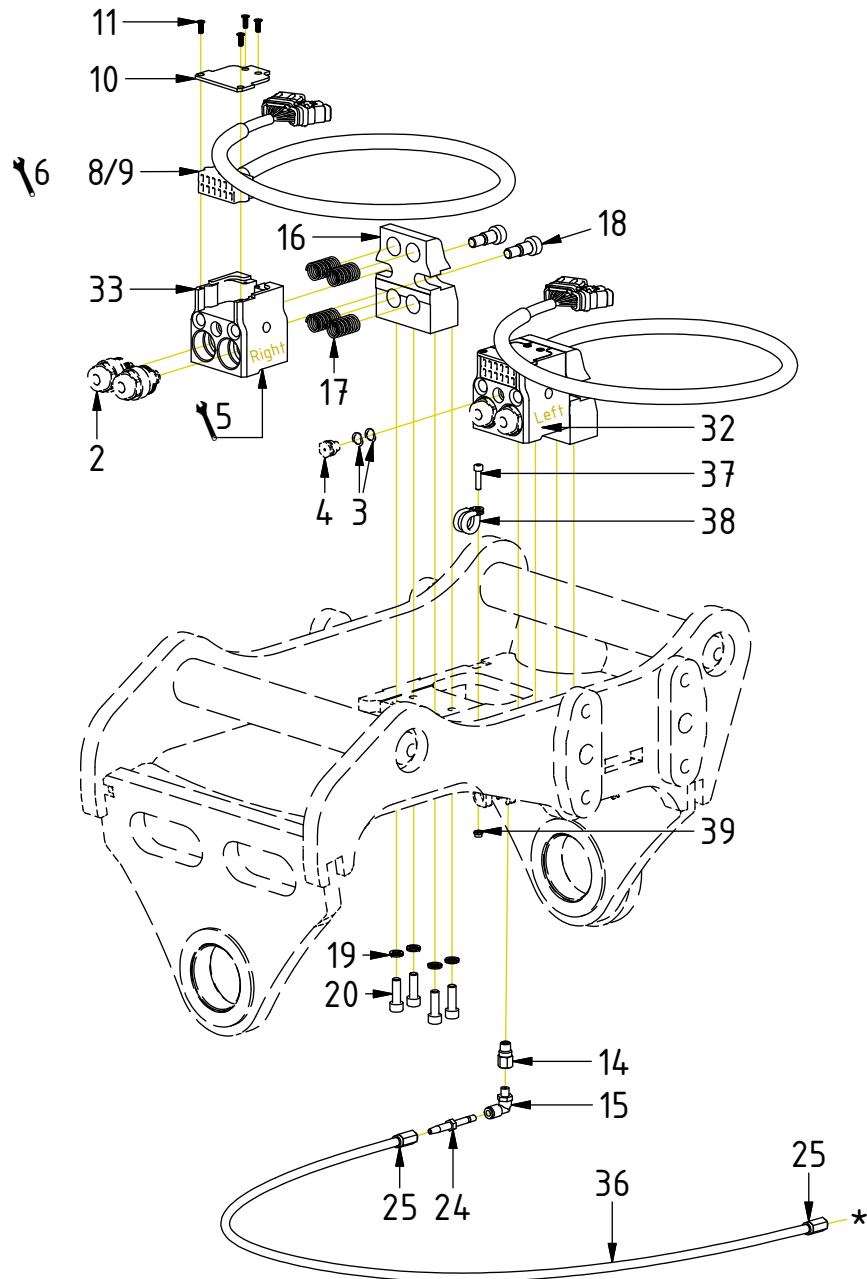

POS	DESCRIPTION	PART	QTY	COMMENTS
2	Coupling ECO45/50 3/8" male	1028873	2	Torque: 60Nm
3	Washer Copper 14x10	6000065	2	
4	Button head fitting 1/8" stainless	810505	1	Loxéal 58-12. Torque: 30Nm
5	Adapters according to Top part			See "Top part"
6	Power plug cable gland torque: 6Nm			
8	Power Plug ECO W - ECHF, QSM	8001089	1	For EC214, EC209B
9	Power Plug ECO W	1042241	1	For EC206, EC209, Top bracket
10	Coverplate ECO45 W Top	1041099	1	
11	Screw MKFT 4x12	6000121	4	
16	Attachment block ECO45 W Top	1041097	1	
17	Spring 18x35	1024794	4	
18	Shoulder bolt \varnothing 12x16/M10	611708	2	Loxéal 83-52
19	Washer NL 8mm	611040	4	
20	Screw MC6S M8x25 12.9 ZFSL	6000143	4	Torque: 40Nm
24	Pipe stub straight Push-in	790175	1	
25	Screw socket HT-hose	7000585	2	
27	Pipe stub 90° Push-in	7000318	1	
28	Adapter 90° Push-in - R1/8"	790184	1	Loxéal 58-12
29	Push-in R1/8"	790172	1	Loxéal 58-12
30	Extender 25/17mm KR1/8"-R1/8"	7000578	1	Loxéal 58-12
32	Block ECO45/50W Top 2hy.1cl. Compl.	1048023	1	(POS.2-4 incl.)
33	Block ECO45/50W Top 2hy. Complete	1048025	1	(POS.3-4 incl.)
36	Grease hose bulk 100m	7001303	1	EC214: 1075mm, EC209B: 845mm EC206: 385mm
37	Screw MC6S M5x20 12.9	610400	1	
38	Rubber steel clamp \varnothing 16	6000009	1	Face downwards
39	Lock Nut M6M M5x0,8 8,8 FZB	610920	1	
57	Transport Protection ECO-Block	1035199	1	Part of make up

*EC214:

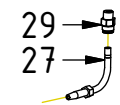

*EC209B:

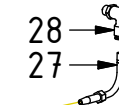

*EC206:

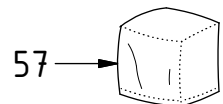
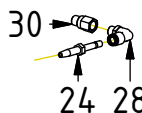

POS in order of assembly

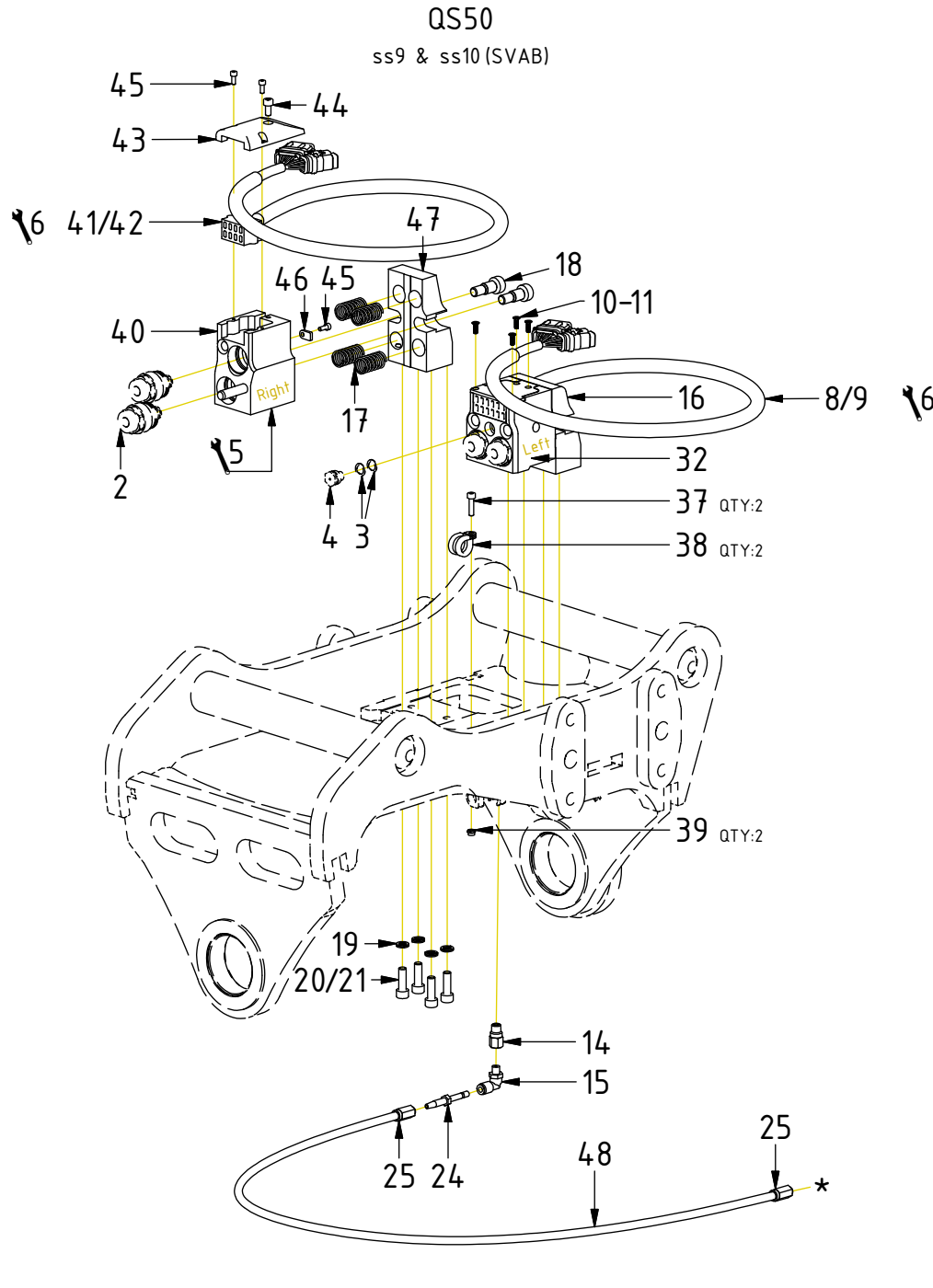

POS	DESCRIPTION	PART	QTY	COMMENTS
2	Coupling ECO45/50 3/8" male	1028873	2	Torque: 60Nm
3	Washer Copper 14x10	6000065	2	
4	Button head fitting 1/8" stainless	810505	1	Loxéal 58-12. Torque: 30Nm
5	Adapters according to Top part			See "Top part"
6	Power plug cable gland torque: 6Nm			
8	Power Plug ECO W - ECHF, QSM	8001089	1	For EC214, EC209B
9	Power Plug ECO W	1042241	1	For EC206, EC209, Top bracket
10	Coverplate ECO45 W Top	1041099	1	
11	Screw MKFT 4x12	6000121	4	
14	Extender M8x1-M8x1 18mm	7000688	1	Loxéal 58-12
15	Push-in swivel 90° M8x1	790173	1	Loxéal 58-12
16	Attachment block ECO45 W Top	1041097	1	
17	Spring 18x35	1024794	4	
18	Shoulder bolt \varnothing 12x16/M10	611708	2	Loxéal 83-52
19	Washer NL 8mm	611040	4	
20	Screw MC6S M8x25 12.9 ZFSHL	6000143	4	Torque: 40Nm
21	K6S 8x25 10.9 untreated	611814	4	For EC209 (6-ch). Torque: 34Nm
24	Pipe stub straight Push-in	790175	1	
25	Screw socket HT-hose	7000585	2	
27	Pipe stub 90° Push-in	7000318	1	
28	Adapter 90° Push-in - R1/8"	790184	1	Loxéal 58-12
32	Block ECO45/50W Top 2hy.1cl. Compl.	1048023	1	(POS.2-4 incl.)
37	Screw MC6S M5x20 12.9	610400	1	
38	Rubber steel clamp \varnothing 16	6000009	1	Face downwards
39	Lock Nut M6M M5x0,8 8,8 FZB	610920	1	
40	Block ECO50 W Top 2hy. Complete	1048074	1	(POS.2 incl.)
41	Power Plug ECO50 W - QSM w. 1x DTM042P	8002006	1	For EC209B
42	Power Plug ECO50 W	1045168	1	
43	Coverplate ECO50 W Top	1041646	1	
44	Screw MC6S M6x12 12.9	610412	1	Loxéal 55-02
45	Screw MC6S M4x10 8,8 FZB	610523	3	Loxéal 55-02
46	Clamping washer	1045180	1	
47	Supportblock ECO50 W right	1041645	1	
48	Grease hose bulk 100m	7001303	1	EC209B: 845mm. EC209: 750mm
57	Transport Protection ECO-Block	1035199	1	Part of make up

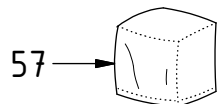
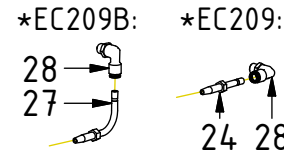

POS in order of assembly

Top bracket QS45 Modular config.

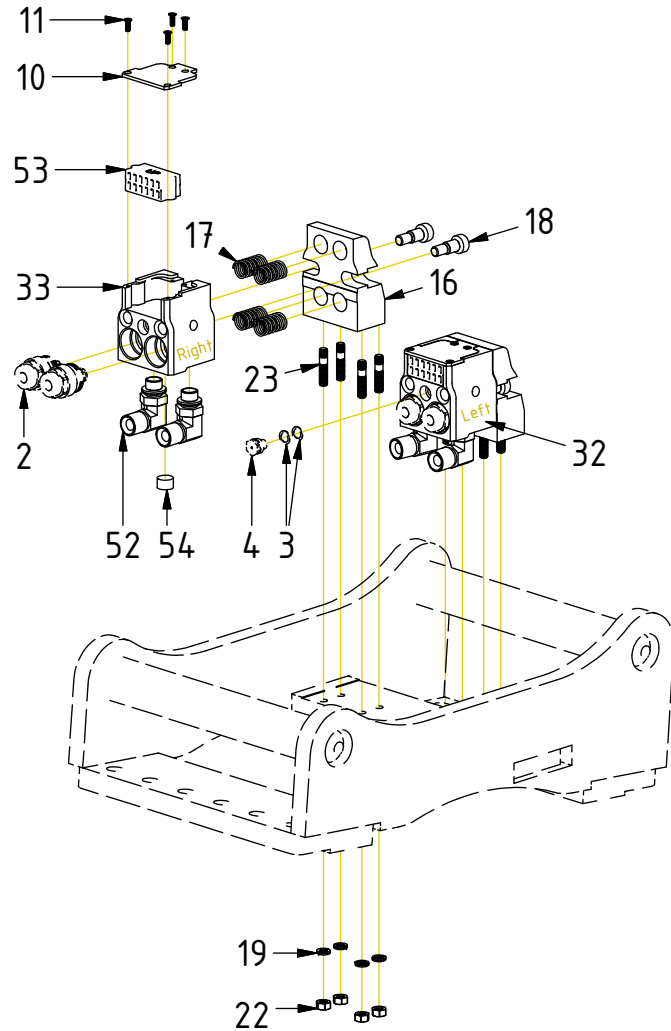

POS	DESCRIPTION	PART	QTY	COMMENTS
2	Coupling ECO45/50 3/8" male	1028873	2	Torque: 60Nm
3	Washer Copper 14x10	6000065	2	
4	Button head fitting 1/8" stainless	810505	1	Loxeal 58-12. Torque: 30Nm
6	Power plug cable gland torque: 6Nm			
9	Power Plug ECO W	1042241	1	For EC206, EC209, Top bracket
10	Coverplate ECO45 W Top	1041099	1	
11	Screw MKFT 4x12	6000121	4	
16	Attachment block ECO45 W Top	1041097	1	
17	Spring 18x35	1024794	4	
18	Shoulder bolt \varnothing 12x16/M10	611708	2	Loxeal 83-52
19	Washer NL 8mm	611040	4	
22	Nut steel m8	611187	4	
23	Stud bolt 8x30	611185	4	
32	Block ECO45/50W Top 2hy.1cl. Compl.	1048023	1	(POS.2-4 incl.)
33	Block ECO45/50W Top 2hy. Complete	1048025	1	(POS.3-4 incl.)
34	Block ECO45 W Top 3hy. Complete	1054418	1	(POS.2, 35 incl.)
35	Coupling ECO 1/4" male	1053693	1	
49	Washer GBR04 1/4	710702	2	
50	Adapter 831-04-04 (1/4")	710149	1	
51	Banjo bolt 4451-04 (1/4")	710271	1	
52	Adapter 401-08-06 90° (1/2"-3/8")	7000233	2	
53	Plug ECO W - Top	1042918	1	
54	Pipe plug DIN 906 M16x1,5	711529	1	
57	Transport Protection ECO-Block	1035199	1	Part of make up

Option 5 hyd:

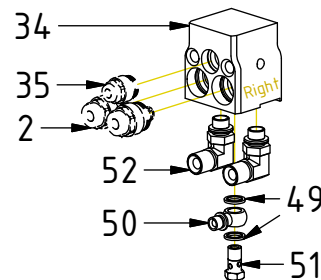

Option 1 el:

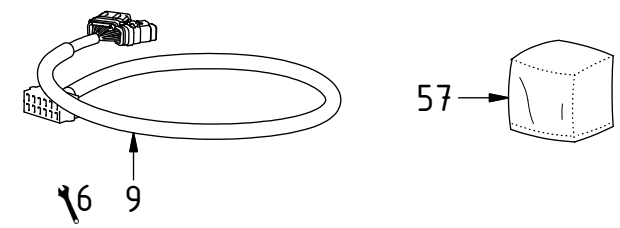

POS in order of assembly

Top bracket QS50 Modular config.

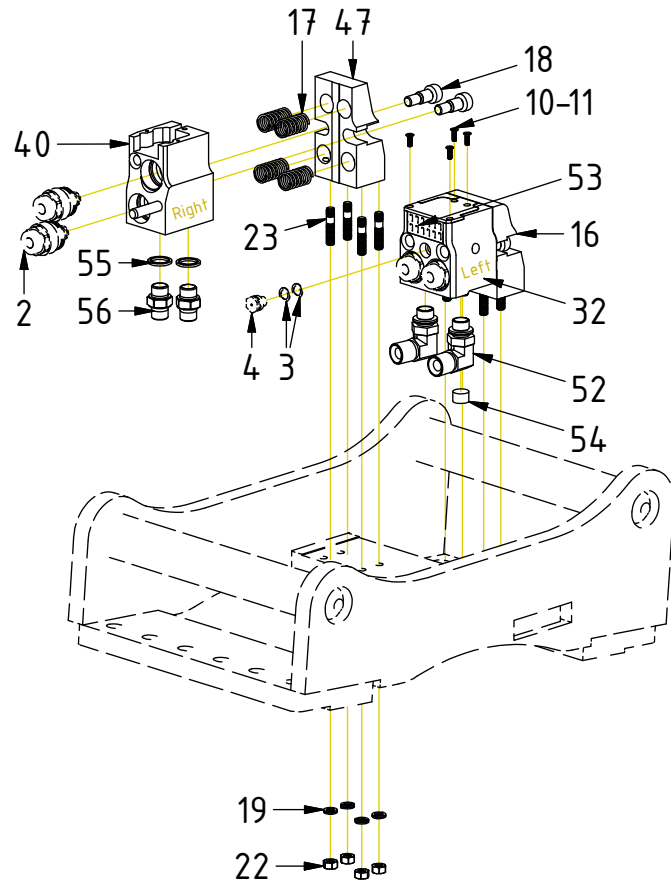

POS	DESCRIPTION	PART	QTY	COMMENTS
2	Coupling ECO45/50 3/8" male	1028873	2	Torque: 60Nm
3	Washer Copper 14x10	6000065	2	
4	Button head fitting 1/8" stainless	810505	1	Loxeal 58-12. Torque: 30Nm
6	Power plug cable gland torque: 6Nm			
9	Power Plug ECO W	1042241	1	For EC206, EC209, Top bracket
10	Coverplate ECO45 W Top	1041099	1	
11	Screw MKFT 4x12	6000121	4	
16	Attachment block ECO45 W Top	1041097	1	
17	Spring 18x35	1024794	4	
18	Shoulder bolt \varnothing 12x16/M10	611708	2	Loxeal 83-52
19	Washer NL 8mm	611040	4	
22	Nut steel m8	611187	4	
23	Stud bolt 8x30	611185	4	
32	Block ECO45/50W Top 2hy.1cl. Compl.	1048023	1	(POS.2-4 incl.)
40	Block ECO50 W Top 2hy. Complete	1048074	1	(POS.2 incl.)
47	Supportblock ECO50 W right	1041645	1	
52	Adapter 4.01-08-06 90° (1/2"-3/8")	7000233	2	
53	Plug ECO W - Top	1042918	1	
54	Pipe plug DIN 906 M16x1,5	711529	1	
55	Washer GBR06 3/8	710703	2	
56	Adapter 136-06-06 (3/8")	710106	2	
57	Transport Protection ECO-Block	1035199	1	Part of make up

Option 1 el:

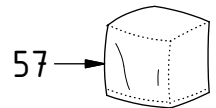
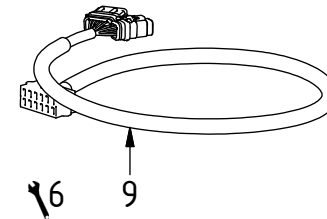

POS in order of assembly

SPARE PARTS

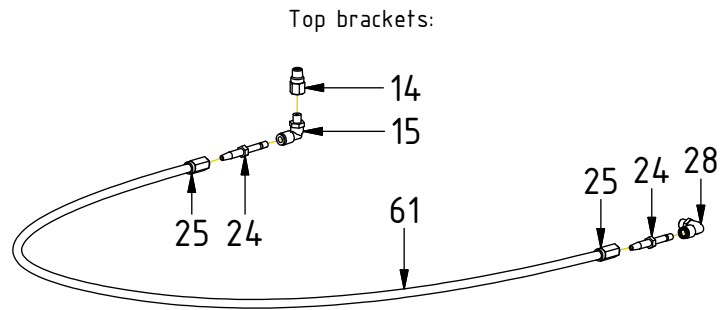
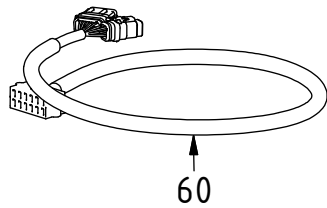
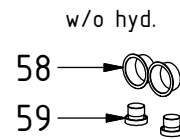
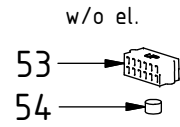

POS	DESCRIPTION	PART	QTY	COMMENTS
8	Power Plug ECO W - ECHF, QSM	8001089	1	For EC214, EC209B
9	Power Plug ECO W	1042241	1	For EC206, EC209, Top bracket
14	Extender M8x1-M8x1 18mm	7000688	1	Loxéal 58-12
15	Push-in swivel 90° M8x1	790173	1	Loxéal 58-12
24	Pipe stub straight Push-in	790175	1	
25	Screw socket HT-hose	7000585	2	
27	Pipe stub 90° Push-in	7000318	1	
28	Adapter 90° Push-in - R1/8"	790184	1	Loxéal 58-12
29	Push-in R1/8"	790172	1	Loxéal 58-12
30	Extender 25/17mm KR1/8"-R1/8"	7000578	1	Loxéal 58-12
31	Grease hose bulk 100m	7001303	1	EC214: 1075mm EC209B: 845mm. EC209: 750mm EC206: 385mm
53	Plug ECO W - Top	1042918	1	
54	Pipe plug DIN 906 M16x1,5	711529	1	
58	Protection plug ECO45/50 Top	7000152	2	
59	Plug 70125-06 (3/8")	711504	2	
60	Power Plug ECO W used on EC214 & Top bracket	1042240	1	Used until 2021-08 Cable gland torque: 6Nm
61	Grease hose bulk 100m	7001303	1	Top bracket: 2000mm

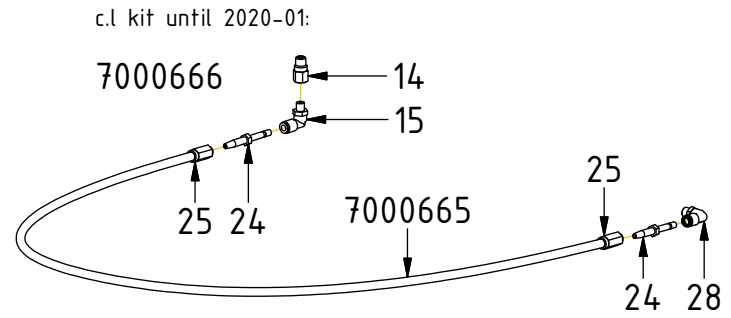
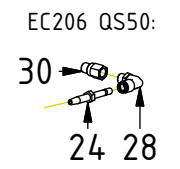
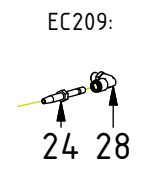
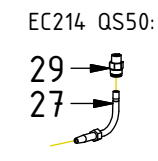
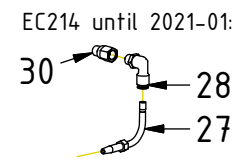

POS in order of assembly