

COVERSHEET

Planned document changes:

Briefly:

POS.9 replaced by 7001663.

Document changes:

<u>Date:</u>	<u>Change:</u>	<u>Rev. after change:</u>
2018-06-20	Layout/irrelevant.	C
2017-09-22	Both quick hitches expired. Coversheet added.	B

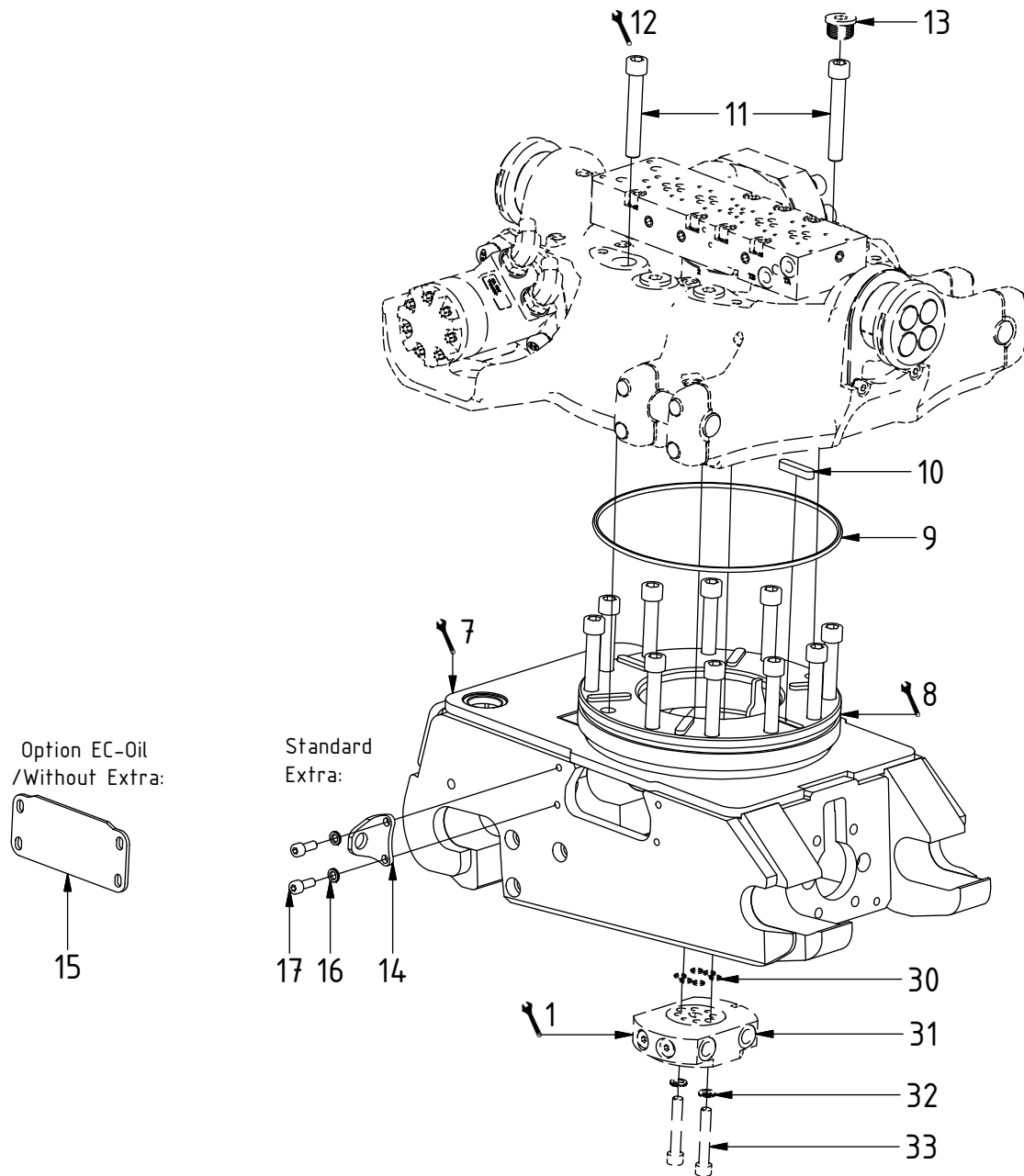

POS	DESCRIPTION	PART	QTY	COMMENTS
1	See p.3 connection block config.			
7	QS45 & QS50 used until 2017-09 (1025365 & 1029737)			Replaced by QSD45 & QSD50 See separate instruction
8	Grease the ring			
9	O-ring 242x5	710965	1	
10	Feather Key	650101	6	
11	Socket Head Screw 14x90	610510	12	Torque: 217Nm
12	Torque tighten quick hitch to rotator frame, six holes. Rotate to access the remaining holes			
13	Pipe Plug M26x1,5	650409	6	Part of rotator frame assembly
14	Holder Extra QS45	1026678	2	
15	Small Cover plate EC-Oil	1025118	2	
16	Washer NL8	611040	4	QTY: 8 for EC-Oil & Without Extra
17	Socket Head Screw 8x20	610433	4	QTY: 8 for EC-Oil & Without Extra
30	O-ring 9,25x1,78	710901	6	Part of rotator frame assembly
31	Connection block EC209 (for slipring)	1025502	1	Part of rotator frame assembly
32	Washer NL10	611041	2	Part of rotator frame assembly
33	Socket Head Screw 10x60	610460	2	Part of rotator frame assembly

Option EC-Oil / Without Extra:

Standard Extra:

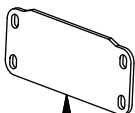

15

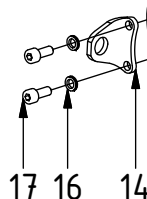

Standard / EC-Oil:

POS	DESCRIPTION	PART	QTY	COMMENTS
2	Plug 3/8"	711504	2	QTY: 4 for EC209 Without Extra
3	Seal washer 1/4"	710702	8	
4	Plug 1/4"	711505	2	
5	Seal washer 3/8"	710703	6	
6	Adapter 136-06-06	710106	2	QTY: 4 for EC-Oil

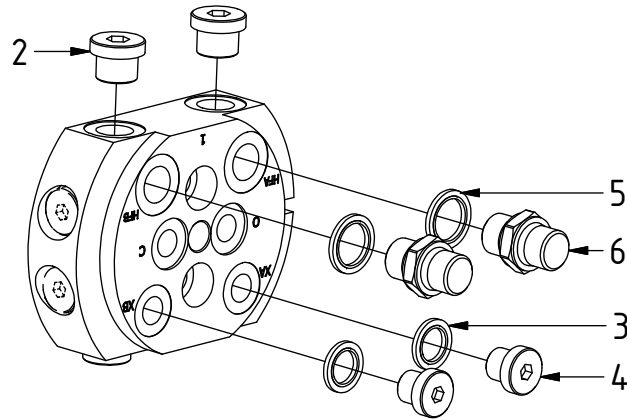

Without Extra:

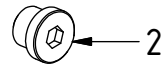

Replaces POS.5-6

POS	DESCRIPTION	PART	QTY	COMMENTS
3	Seal washer 1/4"	710702	8	
5	Seal washer 3/8"	710703	6	
6	Adapter 136-06-06	710106	2	QTY: 4 for EC-Oil
18	Hose Lock Short	742844	1	
19	Hose Lock Long	742843	1	
20	Banjo Bolt 1/4"	710271	2	
21	Hose Extra (Standard)	7000034	2	
22	Bulkhead adapter nut 1270-06	710252	2	
23	Bulkhead adapter	710242	2	
24	Quick coupling 3/8" male 3820	790113	2	
25	Dust protection 3/8"	790120	2	
26	Adapter 1/4"	710135	2	

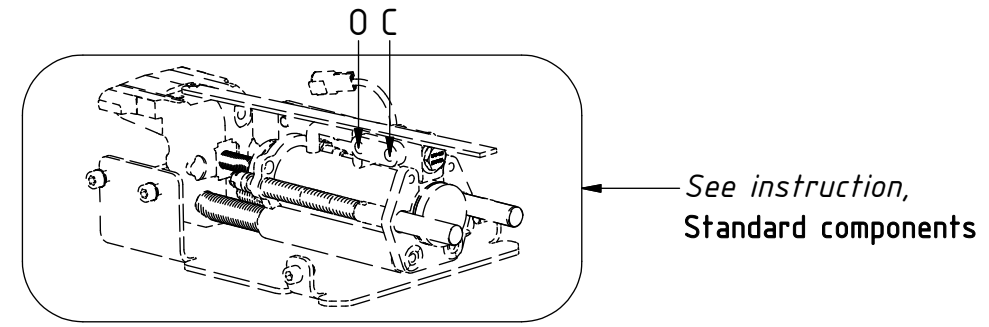
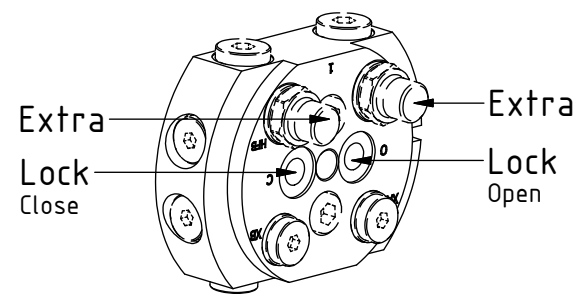
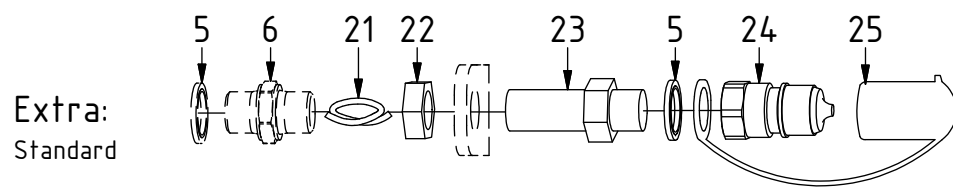
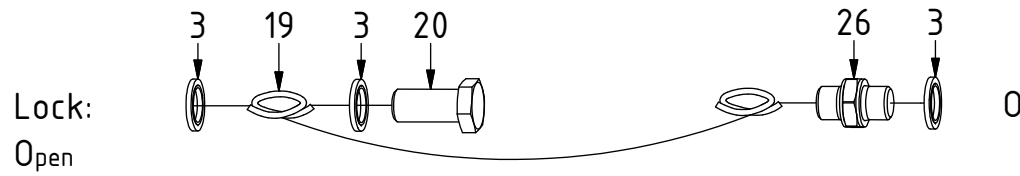
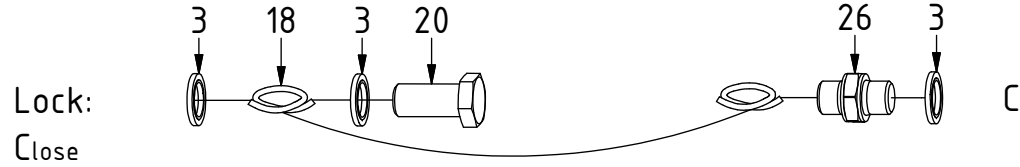

POS	DESCRIPTION	PART	QTY	COMMENTS
5	Seal washer 3/8"	710703	6	
6	Adapter 136-06-06	710106	2	QTY: 4 for EC-Oil
27	Hose Extra (EC-Oil) Long	742848	1	
28	Hose Extra (EC-Oil) Short	742849	1	
29	Adapter 488-06-06 90°	710165	1	

EC-Oil:

Extra A:
EC-Oil

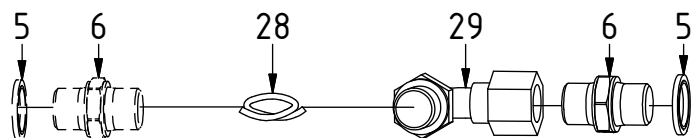

A

Extra B:
EC-Oil

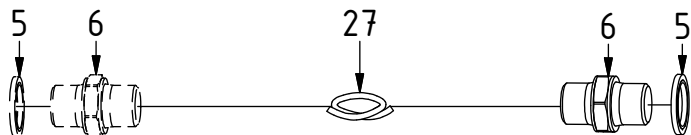

B

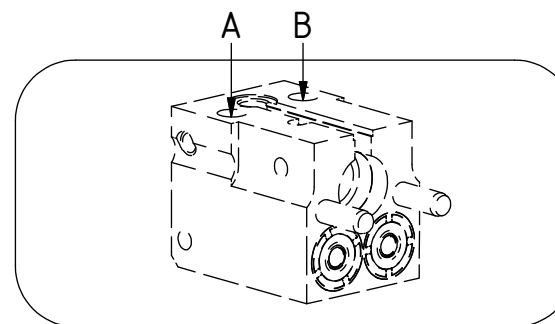
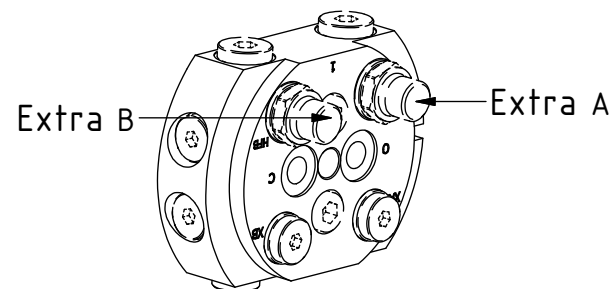

See instruction,
EC-Oil components

EC209 - QS45/QS50

POS	DESCRIPTION	PART	QTY	COMMENTS
18	Hose Lock Short	742844	1	
19	Hose Lock Long	742843	1	
21	Hose Extra (Standard)	7000034	2	
27	Hose Extra (EC-Oil) Long	742848	1	
28	Hose Extra (EC-Oil) Short	742849	1	

Standard:

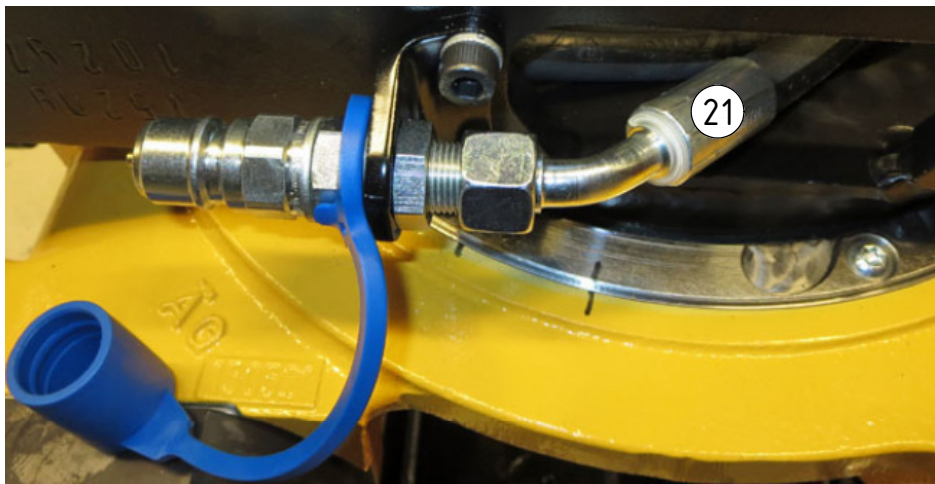
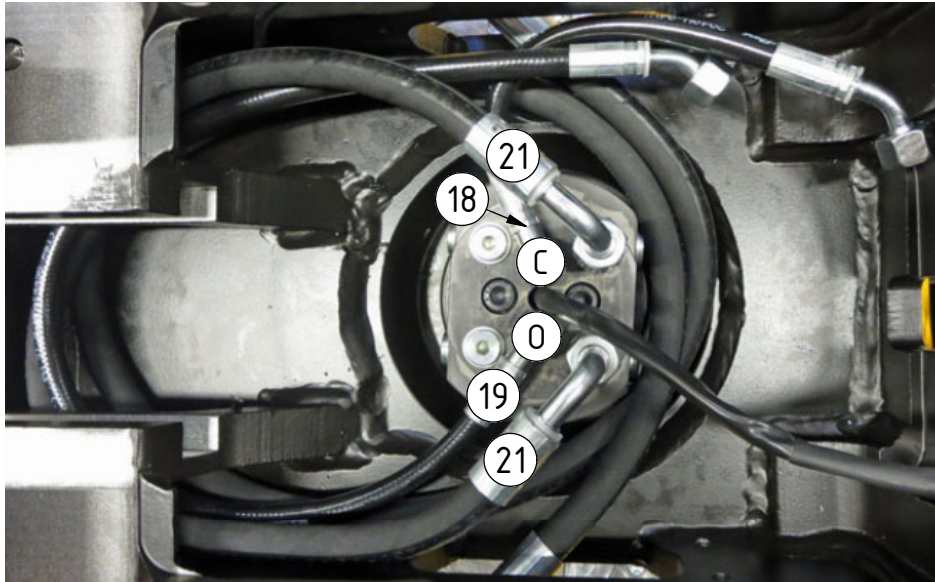

EC-Oil:

