

COVERSHEET

Planned document changes:

Briefly:

 No planned changes.

Document changes:

Date:	Change:	Rev. after change:
2024-05-29	Valves for EC214 updated. ePS1 moved to spare parts.	N
2021-11-03	EC-Oil photos updated.	M
2021-06-07	DC2 updated, QSC connected as standard.	L
2020-08-20	EC226 ePS protection replaced.	K
2019-10-23	EC-Oil Lubrication photos replaced.	J
2019-08-13	ePS cables replaced. ePS photos replaced.	I
2019-06-26	Connecting QSC added, only affects DC2.	H
2019-02-21	Most photos updated.	G
2020-03-27	DC2 EC-Oil ePS tilt ange sensor cable added.	F
2018-09-06	EC30 removed. DC2 EC-Oil cables replaced.	E
2018-06-27	Layout/irrelevant.	D
2018-05-11	Updates regarding lock vavles. Adapter cable added. EC233 added.	C
2017-08-29	Major updates to whole document. Coversheet added.	B

Readers note:
 Indicates instruction.

 Represents Hose.

Dashed lines for overview, mounts
on other pages/assemblies.

EC214, EC219, EC226, EC233

EC219-EC233:

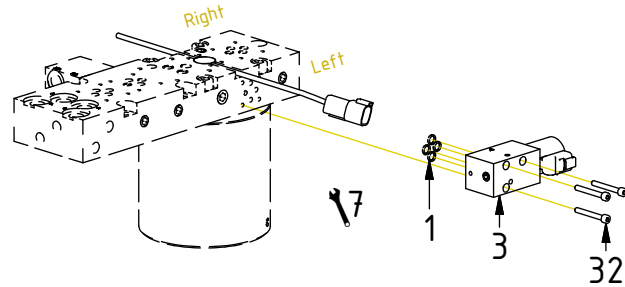
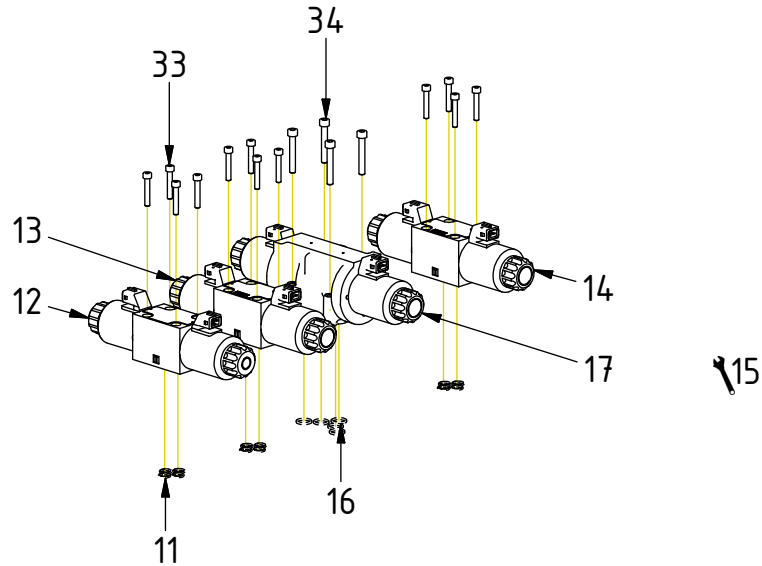

Lock valve JT:

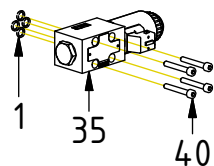

EC-Oil:

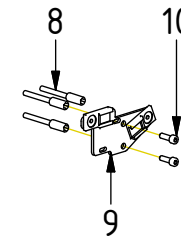

POS	DESCRIPTION	PART	QTY	COMMENTS
1	O-ring 7,65x1,78	710960	8	
3	Directional valve NG4 IQS 24V DT	1042190	1	For QS, CW, ECPUP, ss SIQ (POS.1, 5, 6 incl.)
5	Coil IQS 24V DT	1042066	1	
6	Nut 1270-04	710250	1	
7	For option XP, SQ, SX			See p.11 for instruction
8	Valve spacer M5x39	1047243	3	Torque: 9,7Nm
9	Mounting plate-2x Deutsch NG4	1059664	1	
10	Screw MC6S M5x16 12.9	610401	2	Torque: 9,7Nm
11	O-ring 9,25x1,78	710901	12	
12	Directional valve prop 12V open T	7000092	1	EC219-233 (POS.11, 18, 20 incl.)
13	Directional valve prop 12V	730190	1	EC219-233 (POS.11, 18, 20 incl.)
14	Directional valve NG6 24V	730103	1	EC219-233 (POS.11, 19, 20 incl.)
15	For option PROP on grab/extra			See p.11 for instruction
16	O-ring square 12,42x1,68	750704	5	
17	Directional valve NG10 24V	730339	1	(POS.16, 19, 20 incl.)
18	Coil 12V prop JT	730192	4	
19	Coil 24V JT	730118	4	QTY: 2 for EC214
20	Nut directional valve	730135	8	QTY: 2 for EC214
32	Screw MC6S M5x40 12.9	610405	3	Torque: 9,7Nm
33	Screw MC6S M5x30 12.9	610403	12	Torque: 9,7Nm
34	Screw MC6S M6x40 12.9	610418	4	Torque: 17Nm
35	Directional valve NG4 24V JT	730310	1	(POS.1, 37, 39 incl.)
37	Coil NG4 24V JT	730311	1	
39	Nut directional valve NG4	1006785	1	
40	Screw MC6S M5x35 12.9	610404	4	Torque: 9,7Nm

POS in order of assembly

EC214, EC219, EC226, EC233

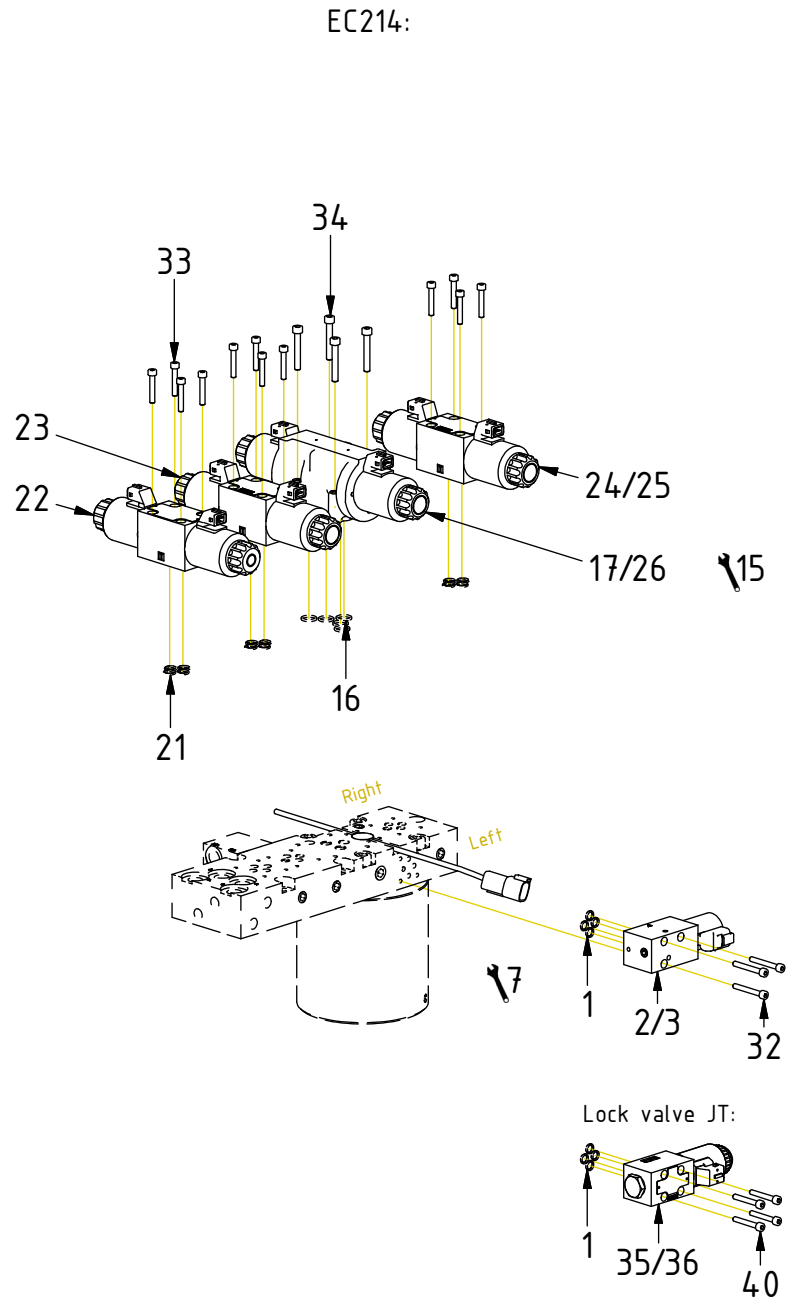

POS	DESCRIPTION	PART	QTY	COMMENTS
1	O-ring 7,65x1,78	710960	8	
2	Directional valve NG4 IQS 12V DT	1042047	1	For QS, CW, ECPUP, ss SIQ (POS.1, 4, 6 incl.)
3	Directional valve NG4 IQS 24V DT	1042190	1	For QS, CW, ECPUP, ss SIQ (POS.1, 5, 6 incl.)
4	Coil IQS 12V DT	1042065	1	
5	Coil IQS 24V DT	1042066	1	
6	Nut 1270-04	710250	1	
7	For option XP, SQ, SX			See p.11 for instruction
8	Valve spacer M5x39	1047243	3	Torque: 9,7Nm
9	Mounting plate-2x Deutsch NG4	1059664	1	
10	Screw MC6S M5x16 12.9	610401	2	Torque: 9,7Nm
15	For option PROP on grab/extra			See p.11 for instruction
16	O-ring square 12,42x1,68	750704	5	
17	Directional valve NG10 24V	730339	1	(POS.16, 19, 20 incl.)
19	Coil 24V JT	730118	4	QTY: 2 for EC214
20	Nut directional valve	730135	8	QTY: 2 for EC214
21	O-ring 8,75x1,78	710959	12	
22	Directional valve prop 12V open T	7001615	1	EC214 (POS.21, 28, 31 incl.)
23	Directional valve prop 12V	7001614	1	EC214 (POS.21, 28, 31 incl.)
24	Directional valve NG6 24V	7001616	1	EC214 (POS.21, 29, 31 incl.)
25	Directional valve NG6 12V	7001617	1	EC214 (POS.21, 30, 31 incl.)
26	Directional valve NG10 12V	730340	1	EC214 (POS.16, 27, 20 incl.)
27	Coil 12V JT	730117	2	
28	Coil NG6 12V prop JT ATOS	7001734	4	
29	Coil NG6 24V JT ATOS	7001736	2	
30	Coil NG6 12V JT ATOS	7001735	2	
31	Nut directional valve ATOS	7001887	6	
32	Screw MC6S M5x40 12.9	610405	3	Torque: 9,7Nm
33	Screw MC6S M5x30 12.9	610403	12	Torque: 9,7Nm
34	Screw MC6S M6x40 12.9	610418	4	Torque: 17Nm
35	Directional valve NG4 24V JT	730310	1	(POS.1, 37, 39 incl.)
36	Directional valve NG4 12V JT	730312	1	(POS.1, 38, 39 incl.)
37	Coil NG4 24V JT	730311	1	
38	Coil NG4 12V JT	730313	1	
39	Nut directional valve NG4	1006785	1	
40	Screw MC6S M5x35 12.9	610404	4	Torque: 9,7Nm

EC-Oil:

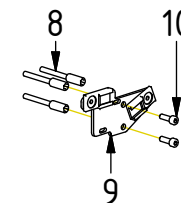

Std. Valves & cables - ss10 (DC2/SVAB) ECHF

Cables
DC2

EC214, EC219, EC226, EC233

POS	DESCRIPTION	PART	QTY	COMMENTS
41	Only for QS, connector			
42	DTM Protection plug	8000090	1	
43	JT Jumper QSC connected	1018662	1	Plug JT connector "1"
44	Tiltrotator module DC2 Q-Safe	842137	1	
45	Screw MC6S M5x12 12.9	6000077	2	
46	Aggregate cable DC2 Compl. QSC DT	8001201	1	
47	Aggregate cable DC2 Comp. QSC JT	8000175	1	For Lock valve JT
48	ILME cover	810208	1	(Incl. with agg.cable)
49	Adapter cable ECOW DC2 DTM 2xM12	8001847	1	For EC-Oil. Instead of agg.cable
50	Protection plate End lock EC209-219	1063372	1	
51	Protection plate End lock EC226	1063521	1	
52	Protection plate End lock EC233	1064168	1	
53	Screw MC6S M12x70 12.9 Geomet	611517	8	For EC214. Torque: 136Nm
54	Screw MC6S 12x90 12.9 ZFSL	6000147	8	For EC219. Torque: 136Nm
55	Screw MC6S 14x80 12.9 ZFSL	6000354	8	For EC226. Torque: 217Nm
56	Screw MC6S M12x80 12.9 ZFSL	6000148	12	For EC233. Torque: 136Nm

POS in order of assembly

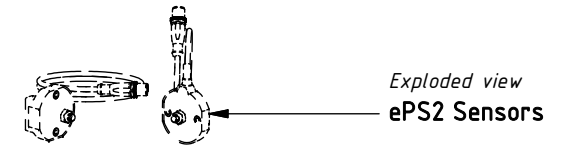
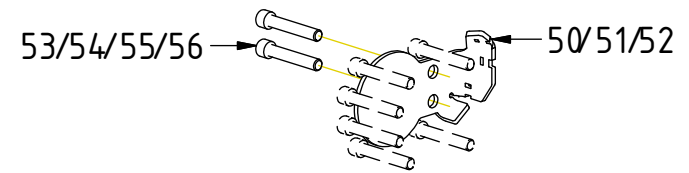
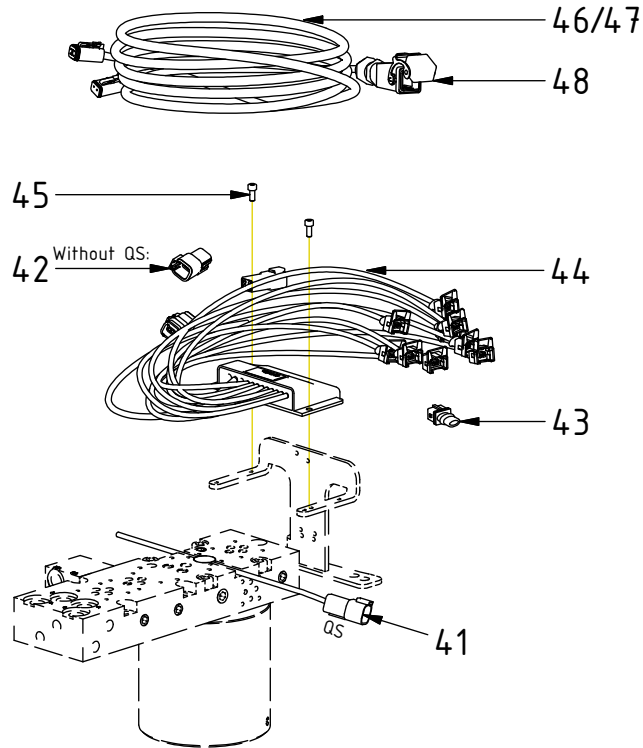

EC-Oil:

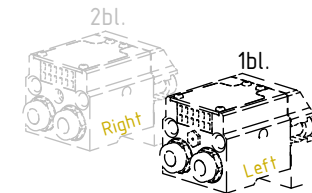
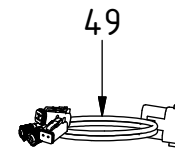

Exploded view
EC-Oil components

Std. Valves & cables - ss10 (DC2/SVAB) ECHF

Cables ss10 (SVAB)

EC214, EC219, EC226, EC233

POS	DESCRIPTION	PART	QTY	COMMENTS
41	Only for QS, connector			
50	Protection plate End lock EC209-219	1063372	1	
51	Protection plate End lock EC226	1063521	1	
52	Protection plate End lock EC233	1064168	1	
53	Screw MC6S M12x70 12.9 Geomet	611517	8	For EC214. Torque: 136Nm
54	Screw MC6S 12x90 12.9 ZFSHL	6000147	8	For EC219. Torque: 136Nm
55	Screw MC6S 14x80 12.9 ZFSHL	6000354	8	For EC226. Torque: 217Nm
56	Screw MC6S M12x80 12.9 ZFSHL	6000148	12	For EC233. Torque: 136Nm
57	Adapter cable JT>DT (Lockvalve DT)	1017478	1	(Previously also for DC2)
58	Aggregate cable SVAB Complete	1015196	1	
59	ILME cover 16P	810235	1	(Incl. with agq.cable)
60	Cable QS QLM tiltrotator SVAB	842148	1	For QS
61	Adapter cable ECO (DTM) SVAB	1029599	2	For EC-Oil. Instead of POS.57-60
62	Adapter cable DT>JT (Lockvalve JT)	8001989	1	For Left adapter cable

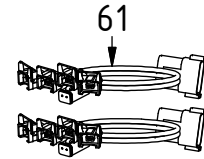
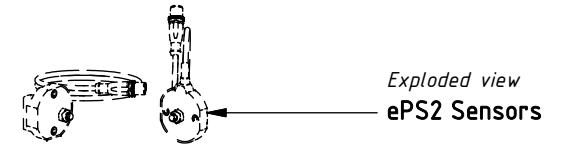
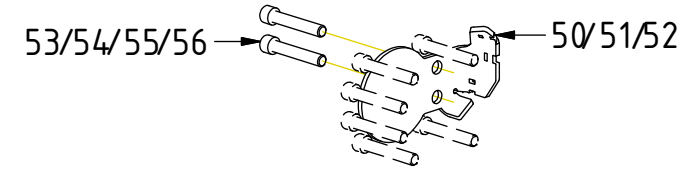
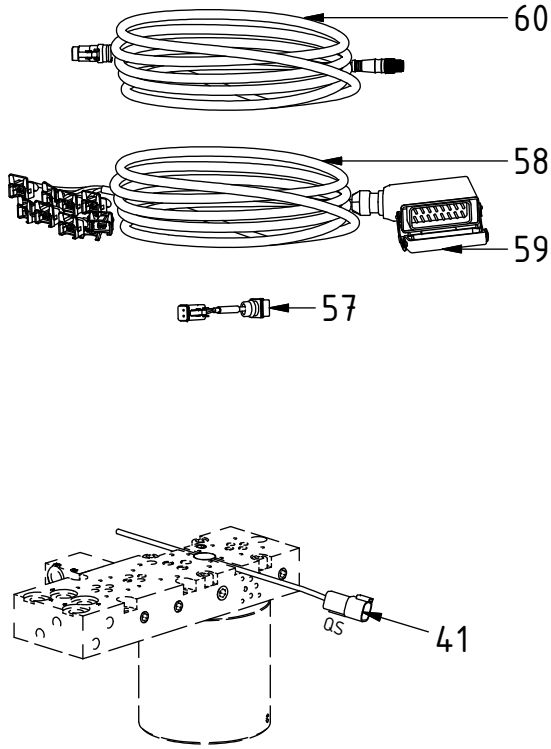

EC-Oil:

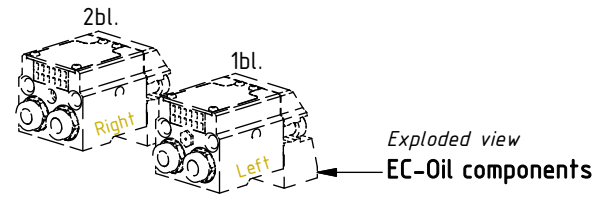

POS in order of assembly

Cables

EC214, EC219, EC226, EC233

DC2 without EC-Oil

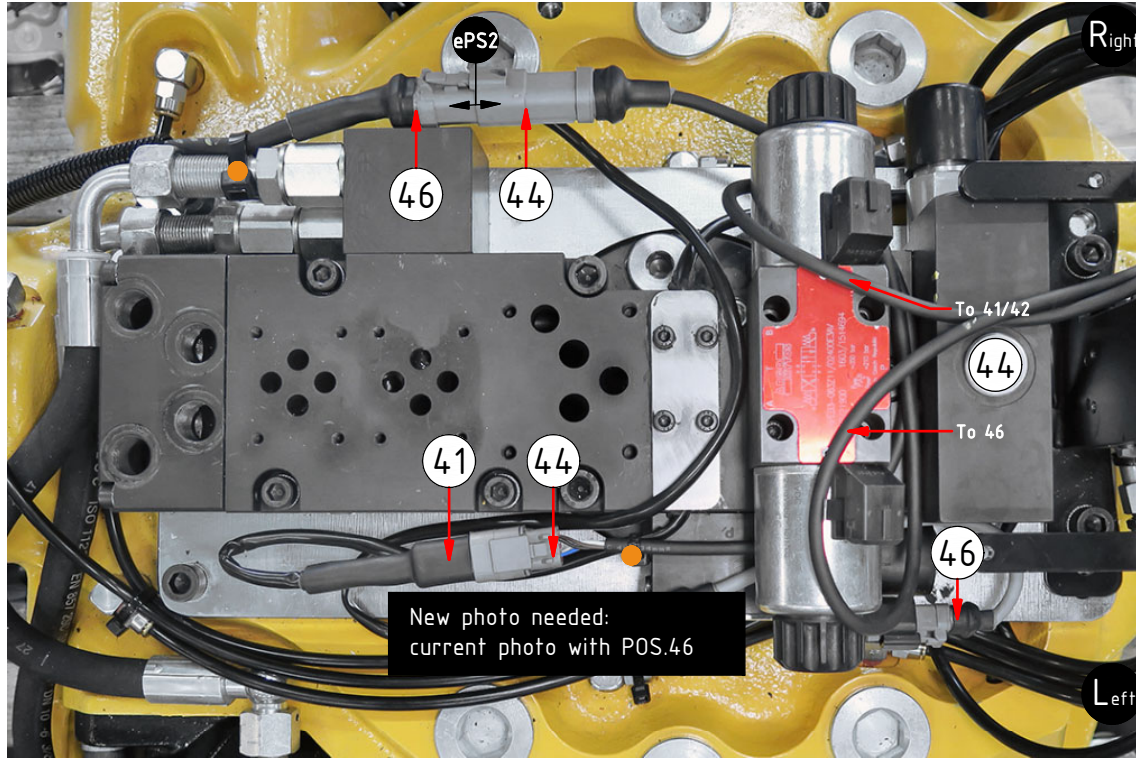

POS	DESCRIPTION	PART	QTY	COMMENTS
41	Only for QS, connector			
42	DTM Protection plug	8000090	1	
44	Tiltrotator module DC2 Q-Safe	842137	1	
46	Aggregate cable DC2 Compl. QSC DT	8001201	1	
47	Aggregate cable DC2 Compl. QSC JT	8000175	1	For Lock valve JT
●	Use cable ties			

Cables Left (std)

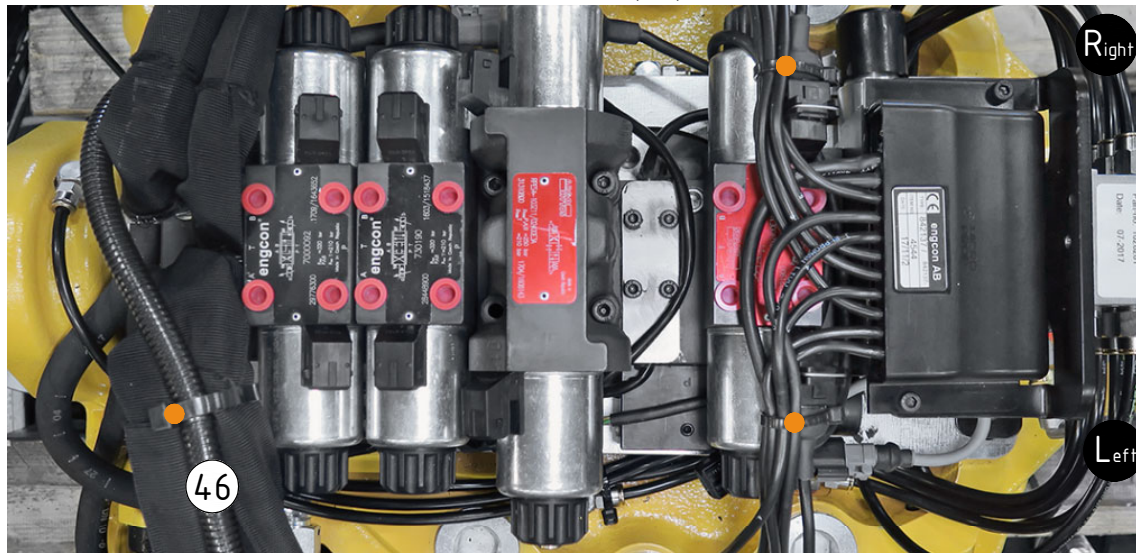

Cables Right (option)

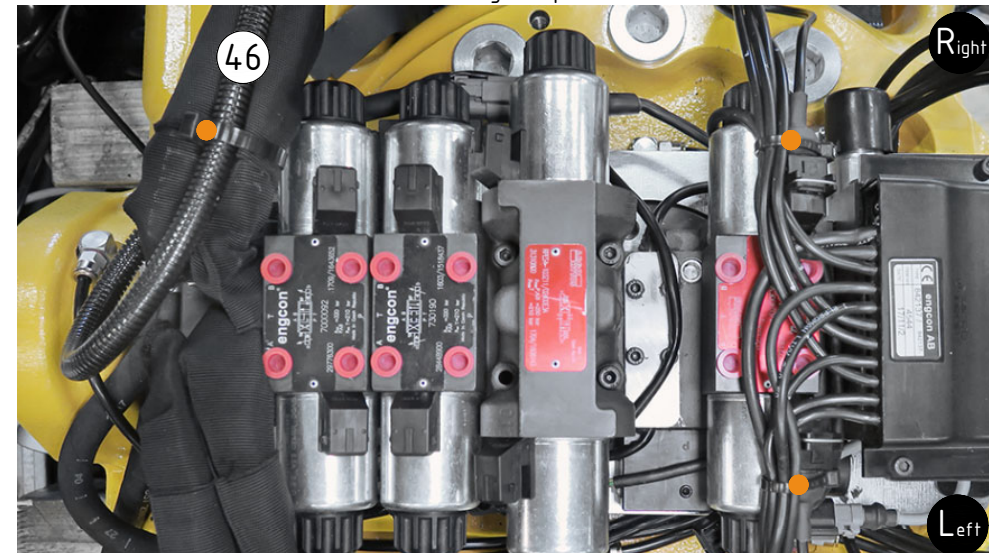

Cables
DC2 EC-Oil

EC214, EC219, EC226, EC233

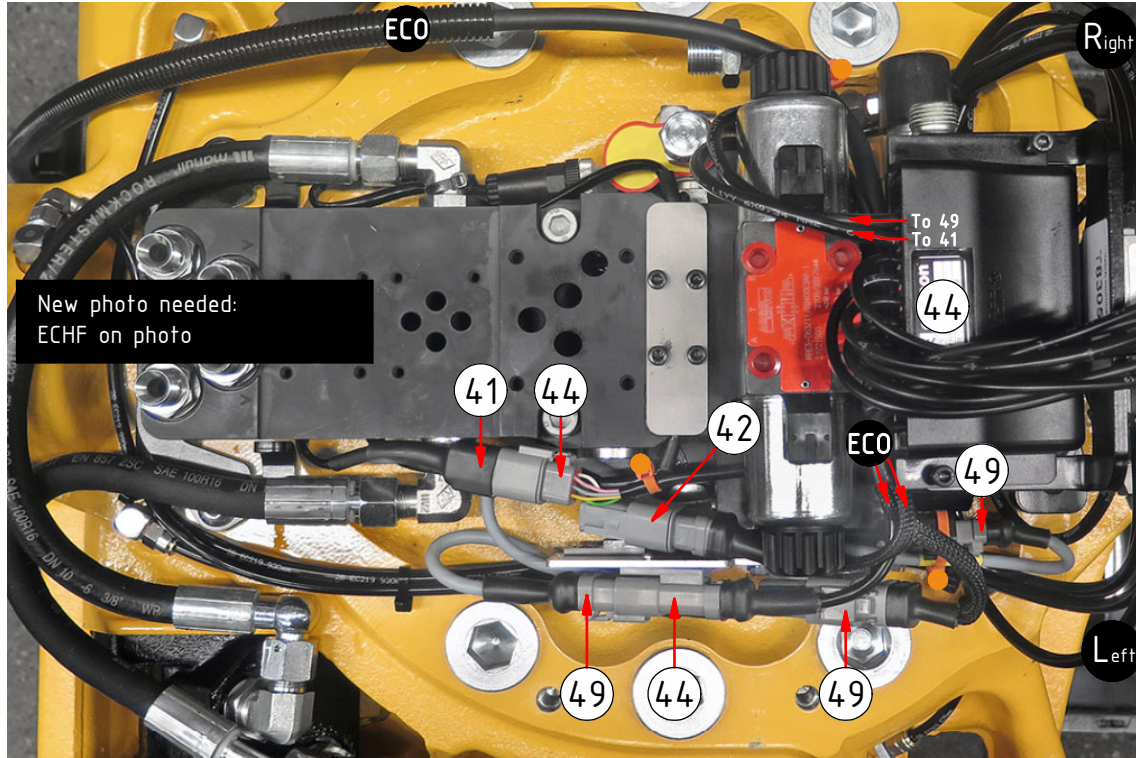

POS	DESCRIPTION	PART	QTY	COMMENTS
41	Only for QS, connector			
42	DTM Protection plug	8000090	1	
44	Tiltrotator module DC2 Q-Safe	842137	1	
49	Adapter cable ECOW DC2 DTM 2xM12	8001847	1	For EC-Oil. Instead of agg.cable

● Use cable ties

POS in order of assembly

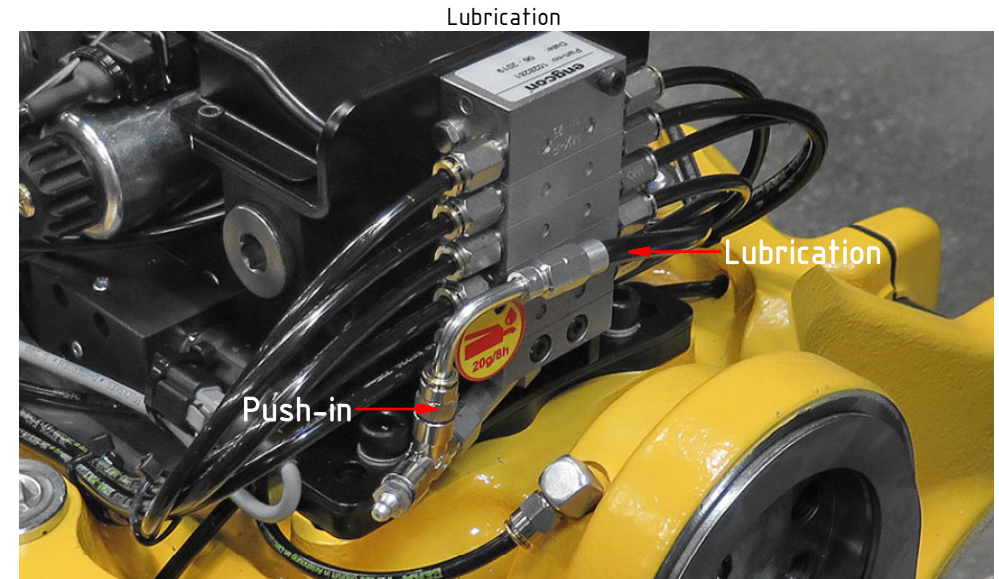
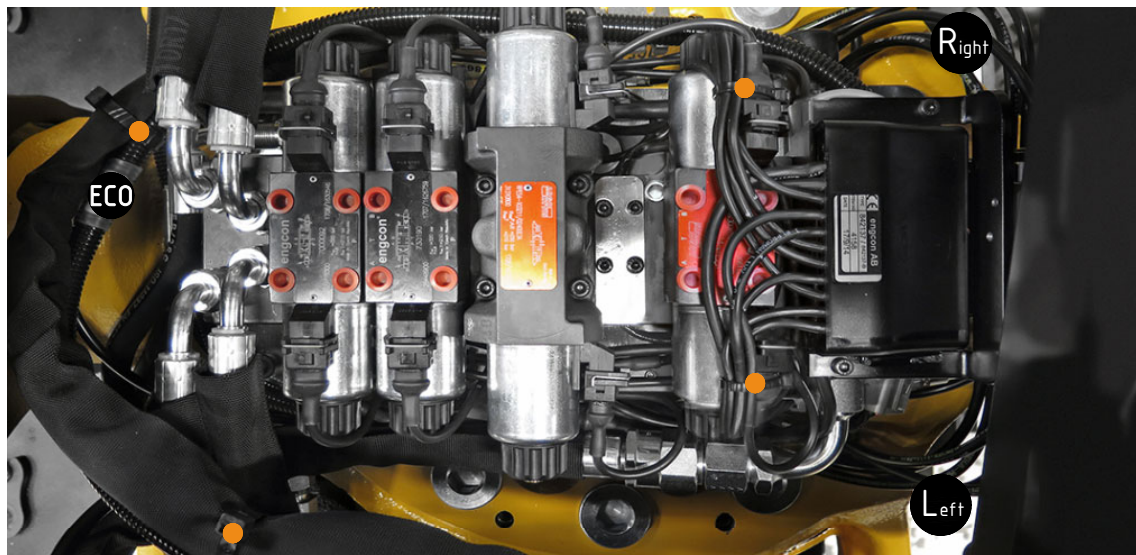

Cables

ss10 (SVAB) without EC-Oil

EC214, EC219, EC226, EC233

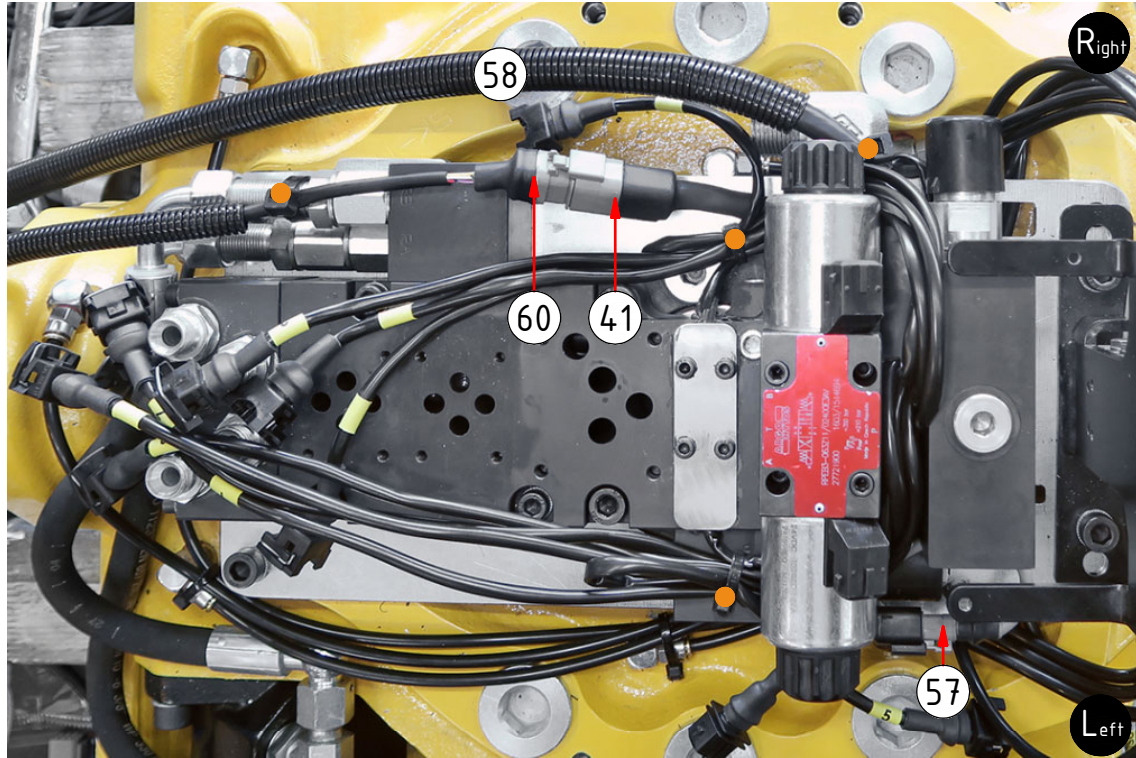

Cables Left (std)

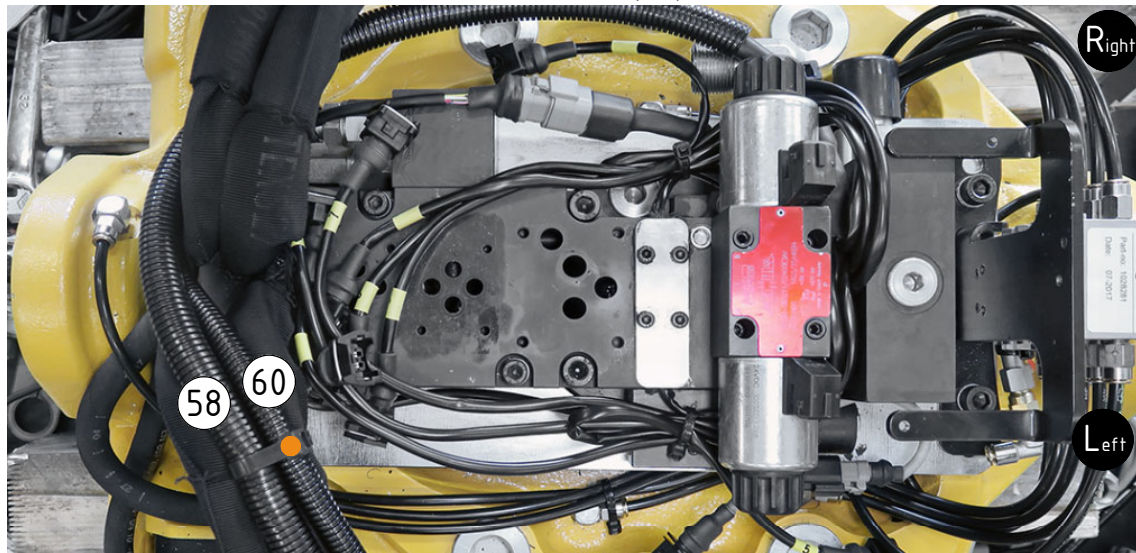

POS	DESCRIPTION	PART	QTY	COMMENTS
41	Only for QS, connector			
57	Adapter cable JT>DT (Lockvalve DT)	1017478	1	(Previously also for DC2)
58	Aggregate cable SVAB Complete	1015196	1	
60	Cable QS QLM tiltrotator SVAB	842148	1	For QS
●	Use cable ties			

POS in order of assembly

Cables Right (option)

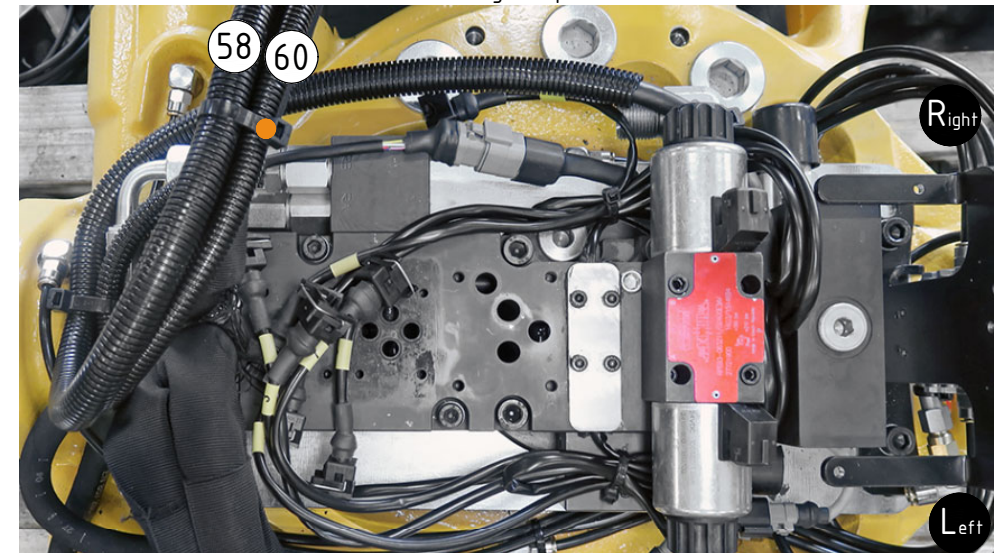

Cables

ss10 (SVAB) EC-Oil

EC214, EC219, EC226, EC233

POS	DESCRIPTION	PART	QTY	COMMENTS
41	Only for QS, connector			
61	Adapter cable ECO (DTM) SVAB	1029599	2	For EC-Oil. Instead of POS.57-60
62	Adapter cable DT>JT (Lockvalve JT)	8001989	1	For Left adapter cable
●	Use cable ties			

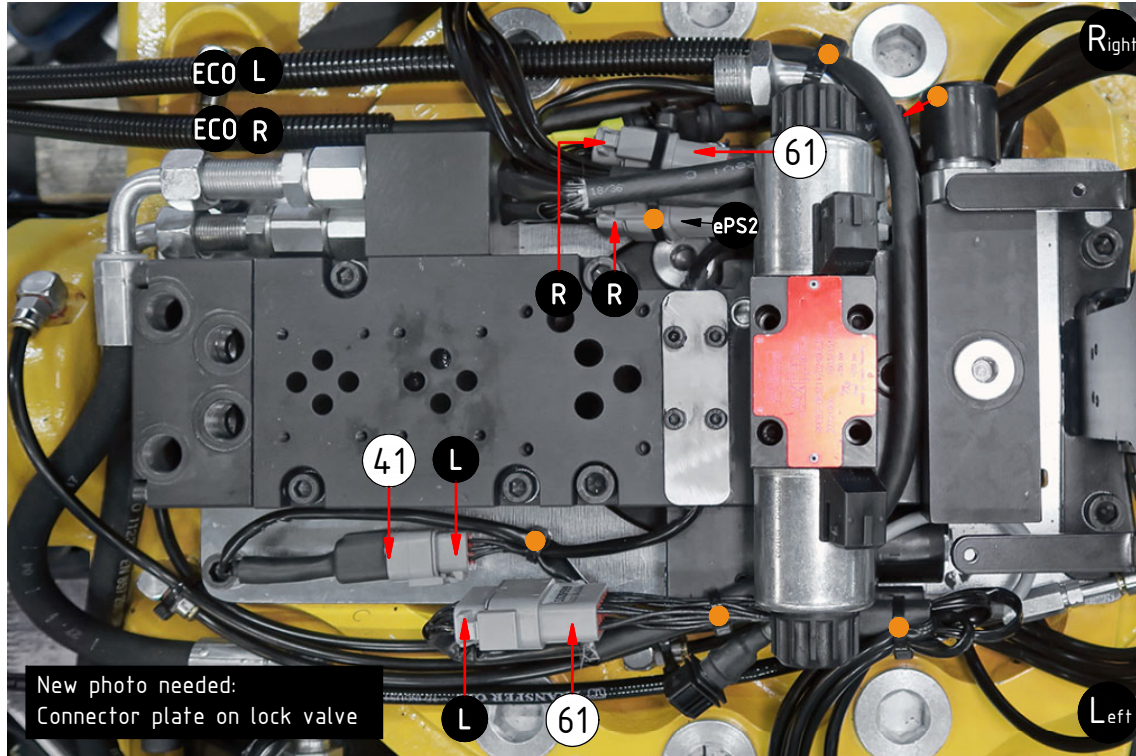

New photo needed:
Connector plate on lock valve

Lubrication

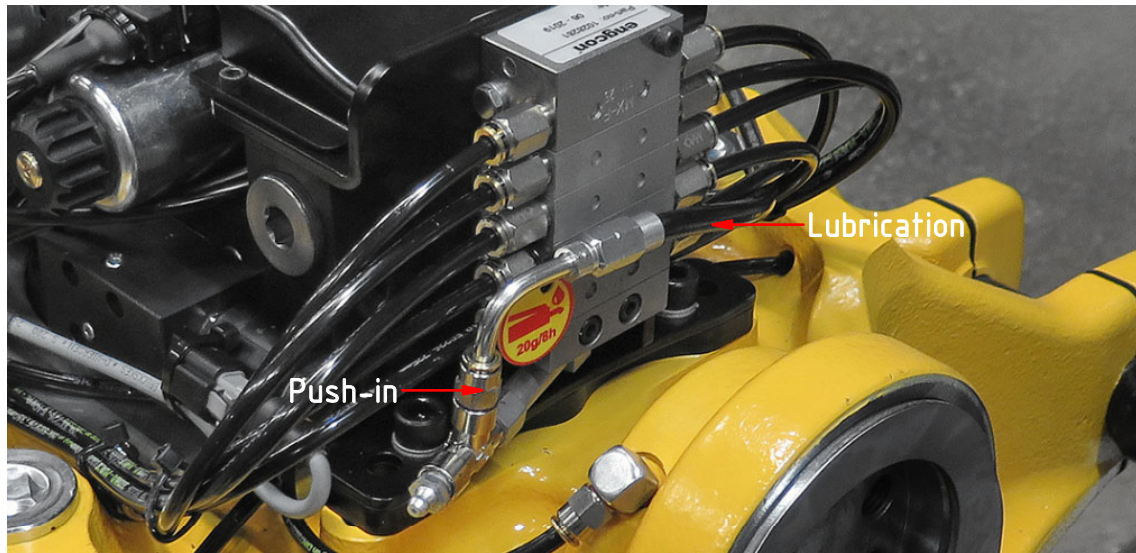

Valves

EC214, EC219, EC226, EC233

POS	DESCRIPTION	PART	QTY	COMMENTS
7	For option XP, SQ, SX			See p.11 for instruction
15	For option PROP on grab/extra			See p.11 for instruction

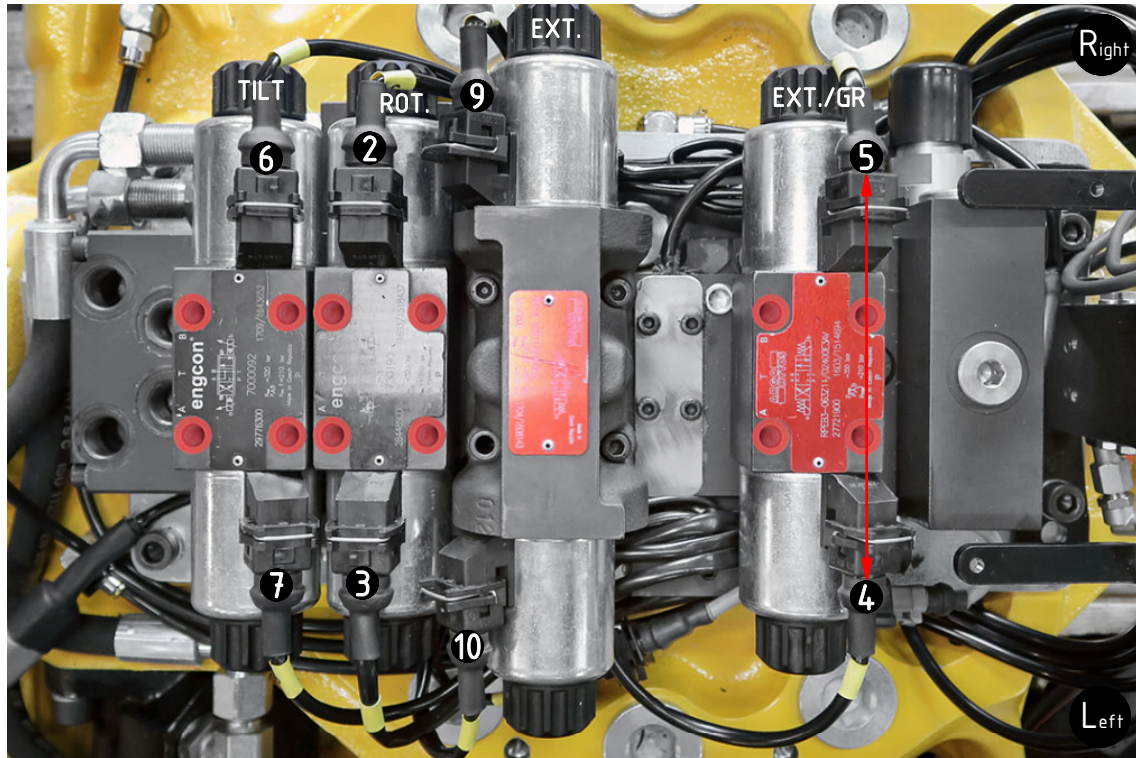

4 & 5 switches place when **NOT** equipped to hold a grab adapter or grab cassette.

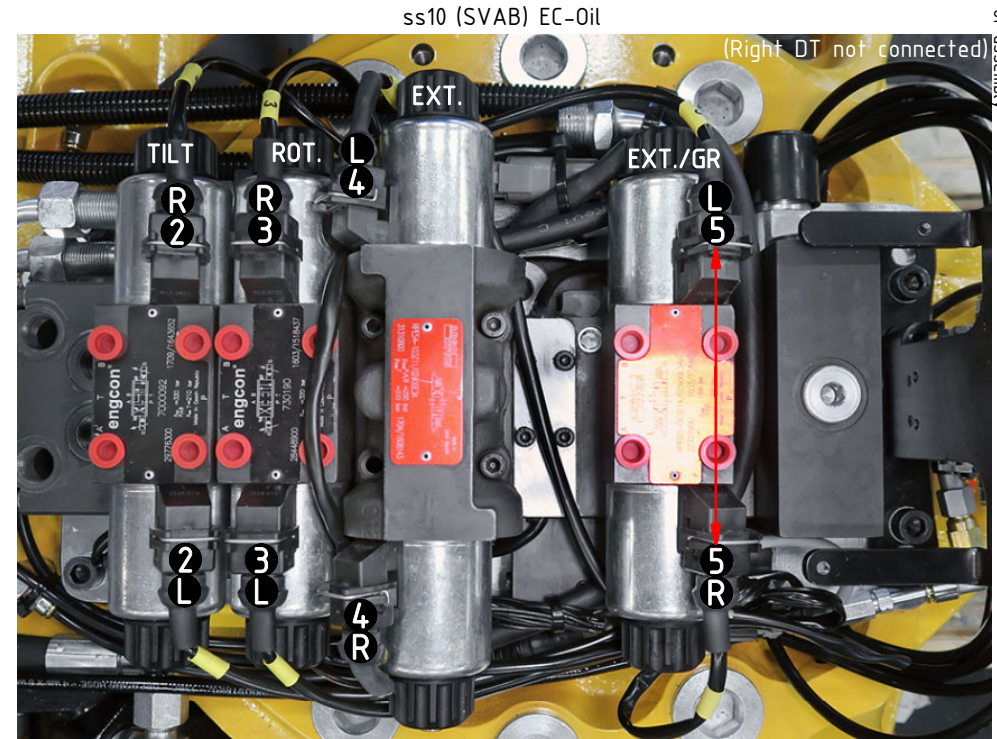

5 & 5 switches place when **NOT** equipped to hold a grab adapter or grab cassette.

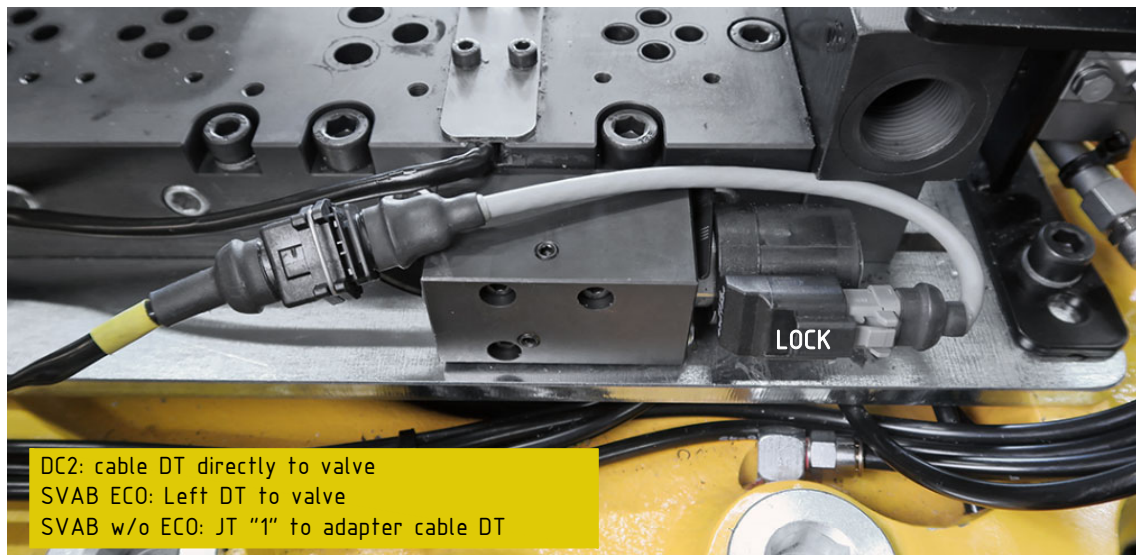

DC2: cable DT directly to valve
 SVAB ECO: Left DT to valve
 SVAB w/o ECO: JT "1" to adapter cable DT

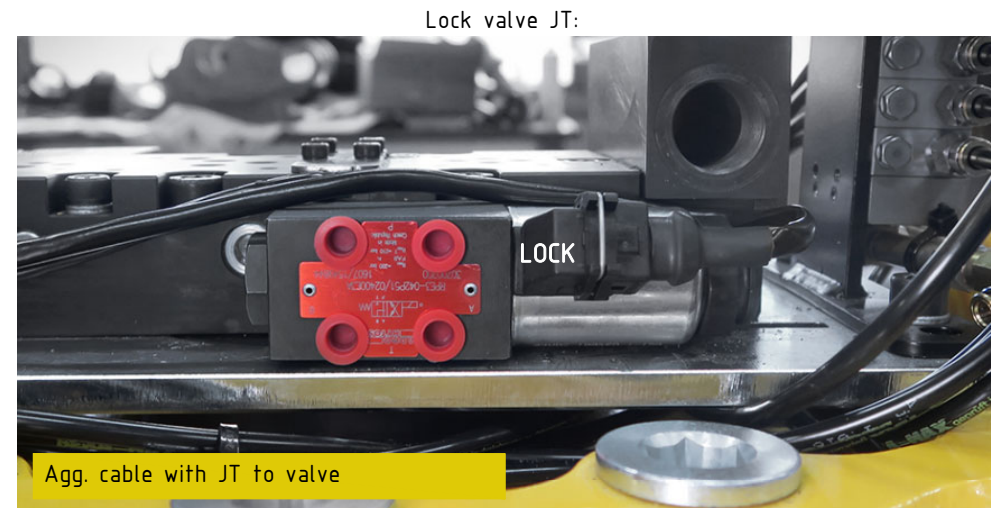

Agg. cable with JT to valve

POS in order of assembly

special/options

XP crossparallel:

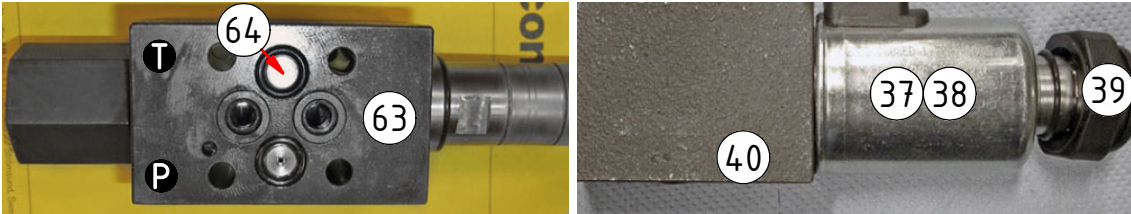

HS08, Arden, MSWH050:

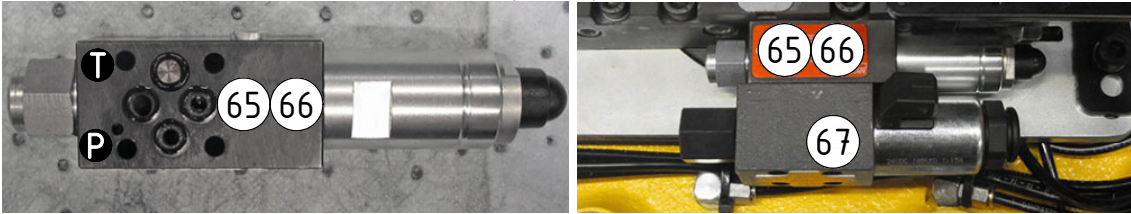

PROP valve on grab/extra

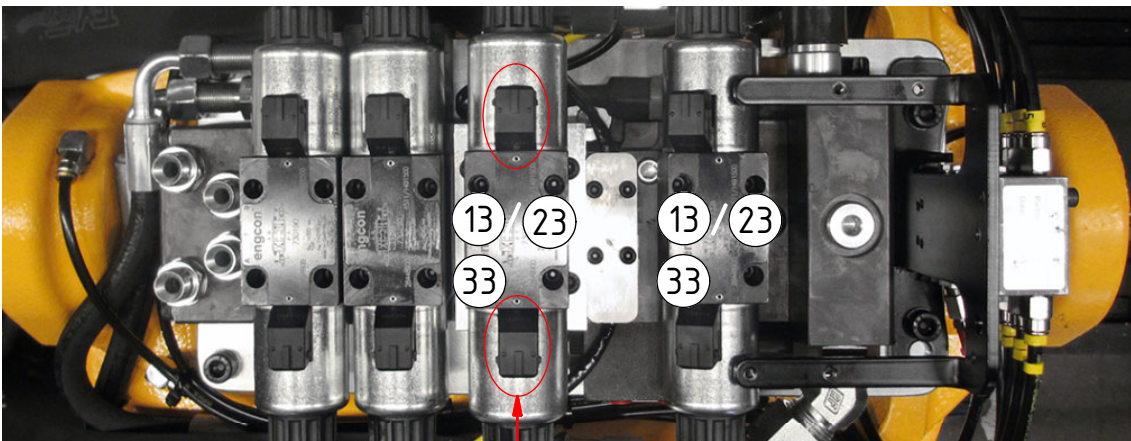
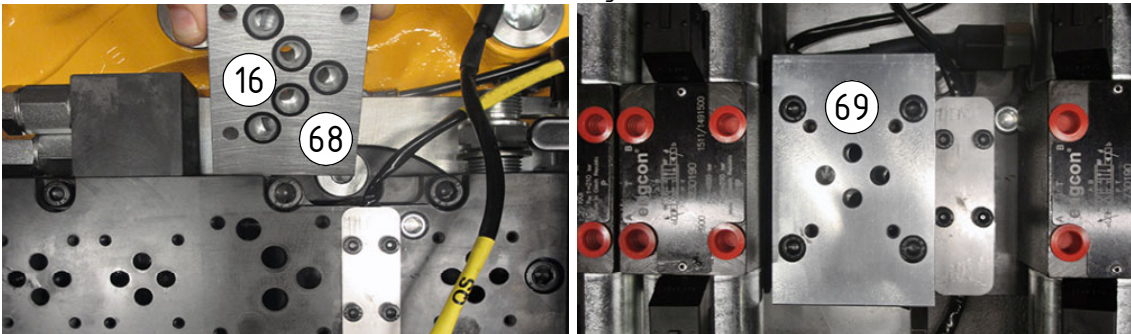

NB! Connectors for valves as standard config. *except* the connectors on EXTRA switches place as **encirkled**.

POS	DESCRIPTION	PART	QTY	COMMENTS
13	Directional valve prop 12V	730190	1	EC219-233 (POS.11, 18, 20 incl.)
16	O-ring square 12,42x1,68	750704	5	
23	Directional valve prop 12V	7001614	1	EC214 (POS.21, 28, 31 incl.)
33	Screw MC6S M5x30 12.9	610403	12	Torque: 9,7Nm
37	Coil NG4 24V JT	730311	1	
38	Coil NG4 12V JT	730313	1	
39	Nut directional valve NG4	1006785	1	
40	Screw MC6S M5x35 12.9	610404	4	Torque: 9,7Nm
63	Directional valve XP crossparallel NG4 without Coil	730321	1	Nut & o-ring with chokevalve incl. Assemble with POS.37/38
64	Plug Dysa D0 for NG4 / VRP2-04	790191	1	Not for HS08, Arden, MSWH050 O-ring incl.
65	Pressure reduction valve VRP2-04-AS/2	7000165	1	For Arden
66	Pressure reduction valve VRP2-04-AS/6	730298	1	For HS08 & MSWH050
67	Screw MC6S 5x65 12.9	6104101	4	Torque: 9,7Nm
68	Adapter plate NG10-NG6	7000147	1	
69	Screw MC6S 6x25	6000083	4	Torque: 17Nm
70	JT Jumper	1018662	1	Plug connector "1" for JT agg.cable
71	JT Plug	1045154	1	Plug connector "9" & "10"

POS in order of assembly

SQ (if JT agg.cable):



SX:

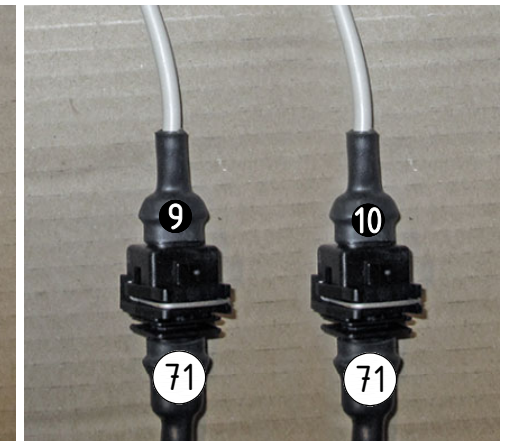

SPARE PARTS

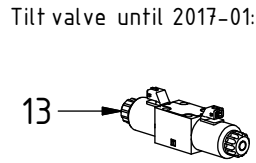
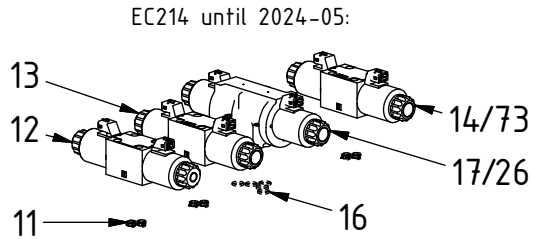

o-rings, coils, & nuts are not compatible between valve brands

ePS1 DC2:

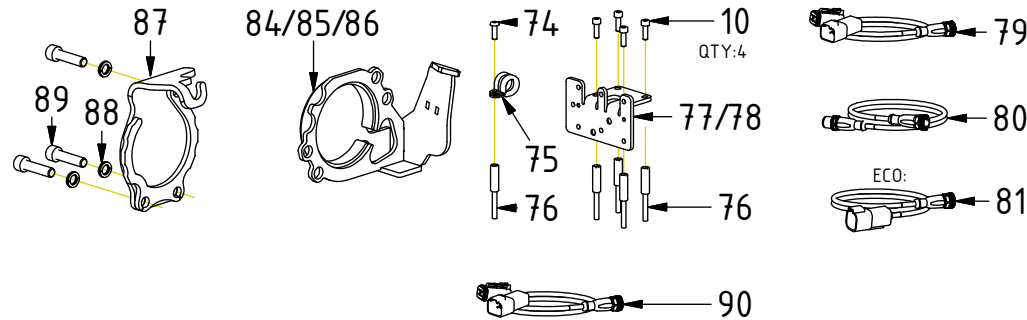

ePS1 ss10 (SVAB):

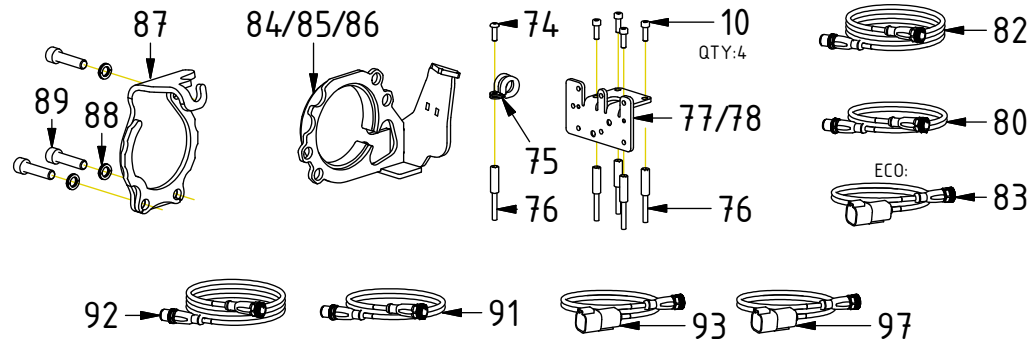

POS	DESCRIPTION	PART	QTY	COMMENTS
10	Screw MC6S M5x16 12.9	610401	2	Torque: 9,7Nm
11	O-ring 9,25x1,78	710901	12	
12	Directional valve prop 12V open T	7000092	1	EC219-233 (POS.11, 18, 20 incl.)
13	Directional valve prop 12V	730190	1	EC219-233 (POS.11, 18, 20 incl.)
14	Directional valve NG6 24V	730103	1	EC219-233 (POS.11, 19, 20 incl.)
16	O-ring square 12,42x1,68	750704	5	
17	Directional valve NG10 24V	730339	1	(POS.16, 19, 20 incl.)
26	Directional valve NG10 12V	730340	1	EC214 (POS.16, 27, 20 incl.)
44	Tiltrotator module DC2 Q-Safe	842137	1	
47	Aggregate cable DC2 Comp. QSC JT	8000175	1	For Lock valve JT
48	ILME cover	810208	1	(Incl. with agg.cable)
57	Adapter cable JT>DT (Lockvalve DT)	1017478	1	(Previously also for DC2)
73	Directional valve NG6 12V	730101	1	(POS.11, 27, 20 incl.)
74	Screw K6S M5x16 10.9 FZB	611818	1	Torque: 8,1Nm
75	Rubber steel clamp ø16	6000009	1	
76	Valve spacer ePS1	1034402	5	Torque: 9,7Nm
77	Bracket ePS1	1038119	1	For Topcon/LEICA/Novatron
78	Bracket ePS1 (Trimble only)	1038117	1	For Trimble
79	Adapter cable DC2 ePS	8000783	1	
80	Adapter cable ePS rotation sensor	8000784	1	
81	Cable Tilt angle sensor ECO W DC2	1048530	1	For EC-Oil with ePS
82	Unit cable ePS w. 120 ohm termin.	8000824	1	
83	Ad.cable ePS ECOW SVAB 120 ohm	8000825	1	For ECO w. ePS. Instead of POS.82
84	Protection EC214PS-EC219PS	1033565	1	
85	Protection EC233PS	1040940	1	
86	Protection EC226PS V2	1055677	1	
87	Protection EC226PS	1016554	1	Replaced by POS.86 from 2020-07
88	Washer NL 10mm	611041	3	
89	Screw MC6S M10x40 12.9	610453	3	
90	Adapter cable DC2 ePS DT DT M12	842173	1	Replaced by POS.79 from 2019-10
91	Adap. cable SVAB ePS rot. sensor	842188	1	Replaced by POS.80 from 2019-10
92	Agg. cable SVAB ePS rot. sensor	842187	1	Replaced by POS.82 from 2019-10
93	Adapter cable ePS ECO W SVAB	1042245	1	Replaced by POS.83 from 2019-10
94	Adapter cable ECO W DC2 DTM	1042249	1	Used until 2018-08
95	Adapter cable ECO W DC2 DTM QSC	1044790	1	Used until 2018-08
96	Adapter cable Lock ECO DC2 QSC	1042250	1	Replaced by POS.95 from 2017-10
97	Cable ePS ECO SVAB	1033021	1	Replaced by POS.93 from 2017-10

Used on DC2 until 2020-12:



Replaced by POS.47 from 2018-01

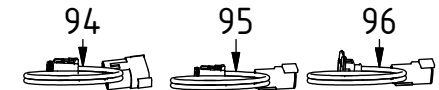
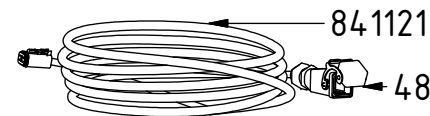

Replaced by POS.44 from 2016-03

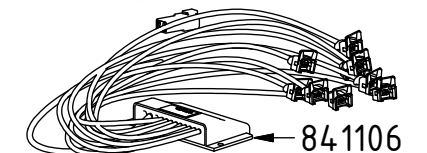

POS in order of assembly

SPARE PARTS

MACS

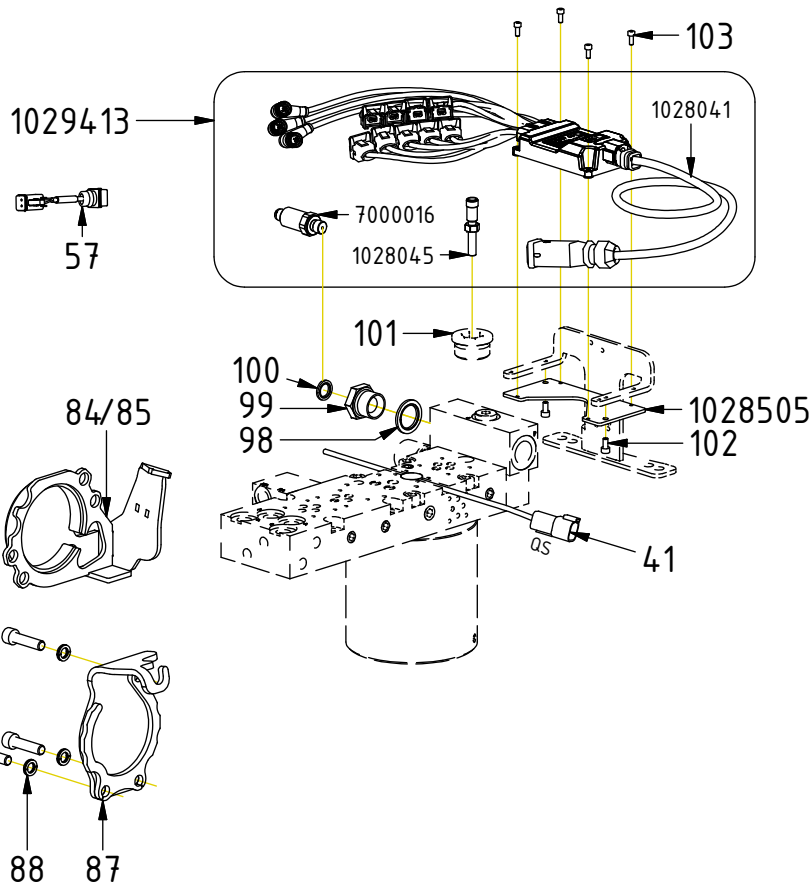

POS	DESCRIPTION	PART	QTY	COMMENTS
41	Only for QS, connector			
57	Adapter cable JT>DT (Lockvalve DT)	1017478	1	(Previously also for DC2)
60	Cable QS QLM tiltrotator SVAB	842148	1	For QS
84	Protection EC214PS-EC219PS	1033565	1	
85	Protection EC233PS	1040940	1	
87	Protection EC226PS	1016554	1	Replaced by POS.86 from 2020-07
88	Washer NL 10mm	611041	3	
89	Screw MC6S M10x40 12.9	610453	3	
98	Washer GBR12 3/4	710706	1	
99	Adapter 234-12-04	7000115	1	
100	Washer GBR04 1/4	710702	1	Used as shim if required
101	Pipe plug M36x2/M8x1 MACS	650411	1	For EC219-EC233. (650412 for EC214)
102	Screw MC6S M5x10 12.9	610594	2	
103	Screw MC6S M4x10 8,8 FZB	610523	4	
104	Adapter cable ECO W MACS-DTM	1043277	1	For ECO. Instead of 1028041+POS.60

EC-Oil:

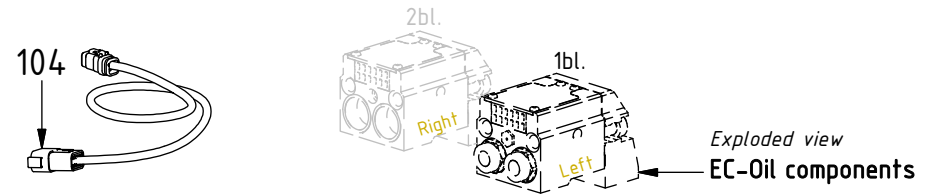

Exploded view
EC-Oil components

POS in order of assembly