

## COVERSHEET

## Planned document changes:

**Briefly:**

---

 No planned changes.

## Document changes:

Date:	Change:	Rev. after change:
2024-11-13	Bearing ring w. screws replaced. Nipple to frame added.	R
2024-06-04	Seal in end lock added.	Q
2024-01-08	Loxal added. O-ring for worm wheel updated.	P
2022-05-23	EC214S added. (EC214 with ePS2 sensors).	O
2022-01-27	Details for end lock added.	N
2021-09-02	Rotator frame replaced. Break support added.	M
2021-05-28	Bearing ring updated.	L
2021-02-17	Torques added and updated.	K
2020-10-09	Rotator frame updated.	J
2019-01-14	Worh wheel 18 holes replaces 12 holes.	I
2018-11-28	QSM added (also applicable for "Without swivel")	H
2018-07-02	Layout/irrelevant.	G
2018-04-23	New location for MACS pipe plug.	F
2017-10-16	Sensor for MACS replaced, new distance 3mm.	E
2017-08-04	Clarifying photo for hoses added. Coversheet added.	D

*Readers note:*
 Indicates instruction.

 Represents Hose.

Dashed lines for overview, mounts  
on other pages/assemblies.

# EC214 - Rotator frame

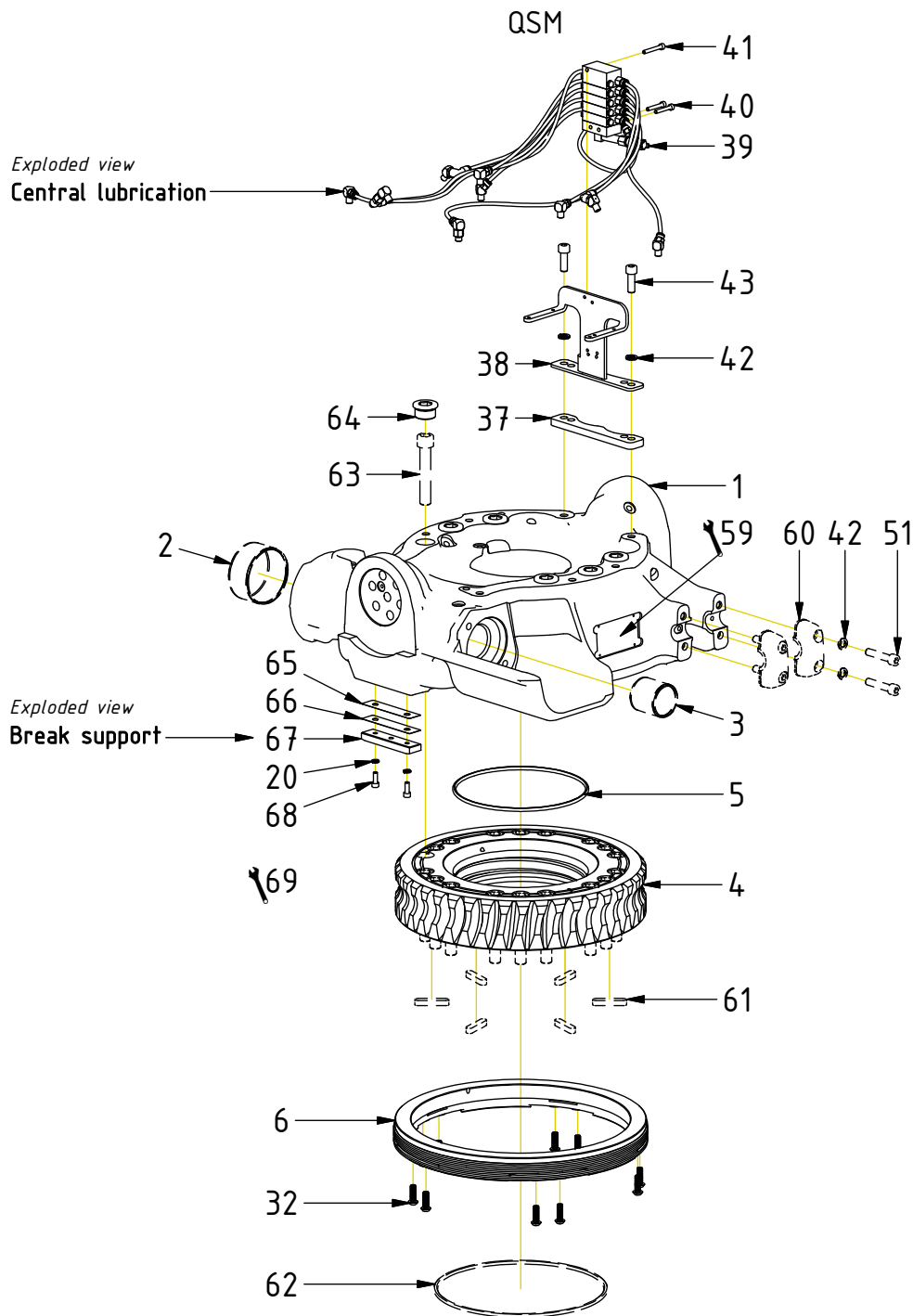

POS	DESCRIPTION	PART	QTY	COMMENTS
1	Rotator frame EC214 V3	1062446	1	(POS.2-3 incl.)
2	Bushing WB802 80/85x40	630103	1	
3	Bushing WB802 45/50x50	630102	1	
4	Worm wheel 18h EC214	1046396	1	
5	O-ring 195x5	7001661	1	
6	Bearing ring EC214 with steering	1077008	1	(Only compatible with 8x25)
20	Washer NL 6mm	611039	2	
32	Screw TX45 8x25 10,9 FZB	1078840	10	Torque: 34Nm Tighten in cross pattern
37	Spacer central lubrication	1047832	1	
38	Mounting plate lube. ECHF/QSM	1031517	1	
39	Lubrication kit	1026699	1	
40	Screw MC6S M5x30 12.9	610403	2	
41	Screw MC6S M5x35 12.9	610404	1	
42	Washer NL 10mm	611041	15	QTY: 8 part of top part
43	Screw MC6S 10x30 12.9 ZFSHL	612018	2	QTY: 4 for ECHF. Torque: 79Nm
51	Screw MC6S M10x50 12.9 ZFSHL	611515	11	QTY: 8 part of top part Torque: 79Nm
59	Punch serial no into rotator frame			
60	Clamping half Complete	1022942	4	Part of top part
61	Feather Key	650102	6	Part of quick hitch
62	O-ring 249,3x5,7	712424	1	Part of quick hitch
63	Screw MC6S M16x90 12.9 ZFSHL	6000151	18	Part of quick hitch. Torque: 333Nm
64	Pipe plug M30x1,5	650410	6	
65	Shim supporting plate 0,1mm	1055262	1	
66	Shim supporting plate 0,3mm	1055260	1	
67	Supporting plate	1055258	1	
68	Screw MC6S M6x16 12.9 ZFSHL	6000017	2	
69	Break play: 0,5 - 0,7mm			Assy. between frame & quick hitch

POS in order of assembly

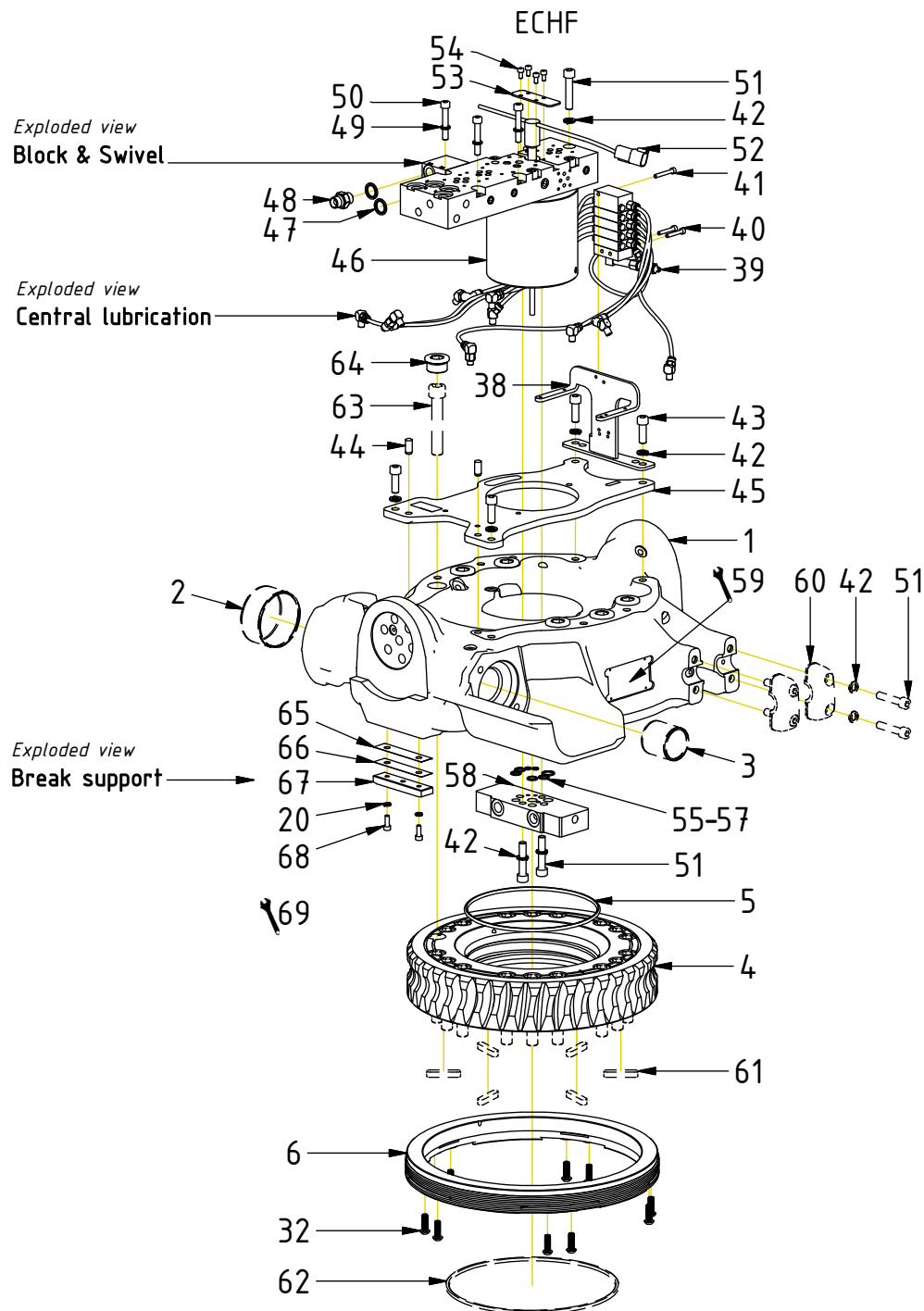

POS	DESCRIPTION	PART	QTY	COMMENTS
1	Rotator frame EC214 V3	1062446	1	(POS.2-3 incl.)
2	Bushing WB802 80/85x40	630103	1	
3	Bushing WB802 45/50x50	630102	1	
4	Worm wheel 18h EC214	1046396	1	
5	O-ring 195x5	7001661	1	
6	Bearing ring EC214 with steering	1077008	1	(Only compatible with 8x25)
32	Screw TX45 8x25 10,9 FZB	1078840	10	Torque: 34Nm Tighten in cross pattern
38	Mounting plate lube. ECHF/QSM	1031517	1	
39	Lubrication kit	1026699	1	
40	Screw MC6S M5x30 12.9	610403	2	
41	Screw MC6S M5x35 12.9	610404	1	
42	Washer NL 10mm	611041	15	QTY: 8 part of top part
43	Screw MC6S 10x30 12.9 ZFSHL	612018	2	QTY: 4 for ECHF. Torque: 79Nm
44	Cylindrical pin CPK ø10x28	6000002	2	
45	Valve plate ECHF	1026199	1	
46	Valve bl. & Swivl for slipring Compl.	1027386	1	
47	Washer GBR06 3/8	710703	2	
48	Adapter 136-06-06 (3/8")	710106	1	
49	Washer NL 8mm	611040	5	
50	Screw MC6S M8x50 12.9	610439	5	
51	Screw MC6S M10x50 12.9 ZFSHL	611515	11	QTY: 8 part of top part Torque: 79Nm
52	Kit slip ring ECHF DTM	1030298	1	For QS. See "Slip rings"
53	Cover plate slip ring	1026200	1	
54	Screw MC6S M5x10 12.9	610594	4	
55	O-ring 6,07x1,78	712422	2	
56	O-ring 12,42x1,78	710973	4	
57	O-ring 15,6x1,78	710912	1	
58	Connection block ECHF	1028391	1	Guide with spring pin from swivel
59	Punch serial no into rotator frame			
60	Clamping half Complete	1022942	4	Part of top part
61	Feather Key	650102	6	Part of quick hitch
62	O-ring 249,3x5,7	712424	1	Part of quick hitch
63	Screw MC6S M16x90 12.9 ZFSHL	6000151	18	Part of quick hitch. Torque: 333Nm
64	Pipe plug M30x1,5	650410	6	
65	Shim supporting plate 0,1mm	1055262	1	
66	Shim supporting plate 0,3mm	1055260	1	
67	Supporting plate	1055258	1	
68	Screw MC6S M6x16 12.9 ZFSHL	6000017	2	
69	Break play: 0,5 - 0,7mm			Assy. between frame & quick hitch

POS in order of assembly

EC214S

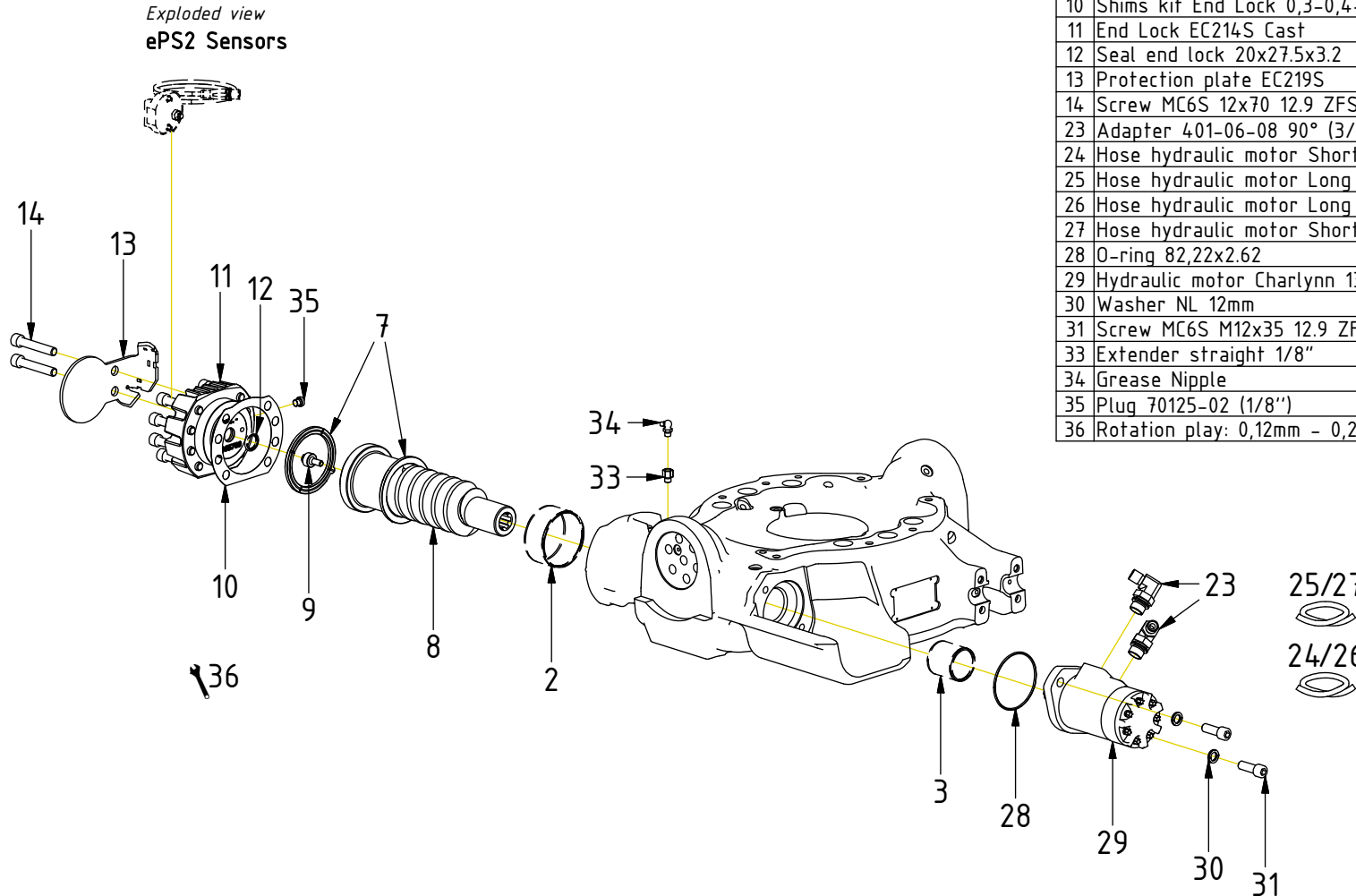

POS	DESCRIPTION	PART	QTY	COMMENTS
2	Bushing WB802 80/85x40	630103	1	
3	Bushing WB802 45/50x50	630102	1	
7	Axial washer (with ear)	1010758	2	Face groove toward worm screw
8	Worm Screw EC219	1016408	1	
9	Magnet Spacer Worm Screw	1062693	1	Loxeal 83-52. Torque: 20Nm
10	Shims kit End Lock 0,3-0,4-0,5 mm	1034434	1	
11	End Lock EC214S Cast	1065789	1	(POS.12 incl.)
12	Seal end lock 20x27.5x3.2	1063616	1	
13	Protection plate EC219S	1063372	1	
14	Screw MC6S 12x70 12.9 ZFSL	611517	8	Torque: 136Nm
23	Adapter 401-06-08 90° (3/8"-1/2")	710157	2	
24	Hose hydraulic motor Short QSM	7000789	1	Part of quick hitch
25	Hose hydraulic motor Long QSM	7000790	1	Part of quick hitch
26	Hose hydraulic motor Long ECHF	743005	1	
27	Hose hydraulic motor Short ECHF	743006	1	
28	O-ring 82,22x2.62	7000920	1	
29	Hydraulic motor Charlynn 131cc	720112	1	
30	Washer NL 12mm	611042	2	
31	Screw MC6S M12x35 12.9 ZFSL	6000150	2	Torque: 136Nm
33	Extender straight 1/8"	712216	1	
34	Grease Nipple	711409	1	
35	Plug 70125-02 (1/8")	711503	1	
36	Rotation play: 0,12mm - 0,20mm			Note rotation play on module card

POS in order of assembly

EC214/EC214PS

POS	DESCRIPTION	PART	QTY	COMMENTS
2	Bushing WB802 80/85x40	630103	1	
3	Bushing WB802 45/50x50	630102	1	
7	Axial washer (with ear)	1010758	2	Face groove toward worm screw
8	Worm Screw EC219	1016408	1	
10	Shims kit End Lock 0,3-0,4-0,5 mm	1034434	1	
15	End lock EC209/EC214/EC219	1016557	1	
16	Screw MC6S M12x80 12.9 ZFSHL	6000148	8	Torque: 136Nm
17	Spacer Plate	1065370	1	
18	O-ring 27x5	7000485	1	
19	Cover end lock	1041613	1	
20	Washer NL 6mm	611039	2	
21	Screw MC6S M6x20 A4-80	611513	3	
22	Protection ePS	1033565	1	For ePS1
23	Adapter 401-06-08 90° (3/8"-1/2")	710157	2	
24	Hose hydraulic motor Short QSM	7000789	1	Part of quick hitch
25	Hose hydraulic motor Long QSM	7000790	1	Part of quick hitch
26	Hose hydraulic motor Long ECHF	743005	1	
27	Hose hydraulic motor Short ECHF	743006	1	
28	O-ring 82,22x2.62	7000920	1	
29	Hydraulic motor Charlynn 131cc	720112	1	
30	Washer NL 12mm	611042	2	
31	Screw MC6S M12x35 12.9 ZFSHL	6000150	2	Torque: 136Nm
33	Extender straight 1/8"	712216	1	
34	Grease Nipple	711409	1	
36	Rotation play: 0,12mm - 0,20mm			Note rotation play on module card

Option ePS:

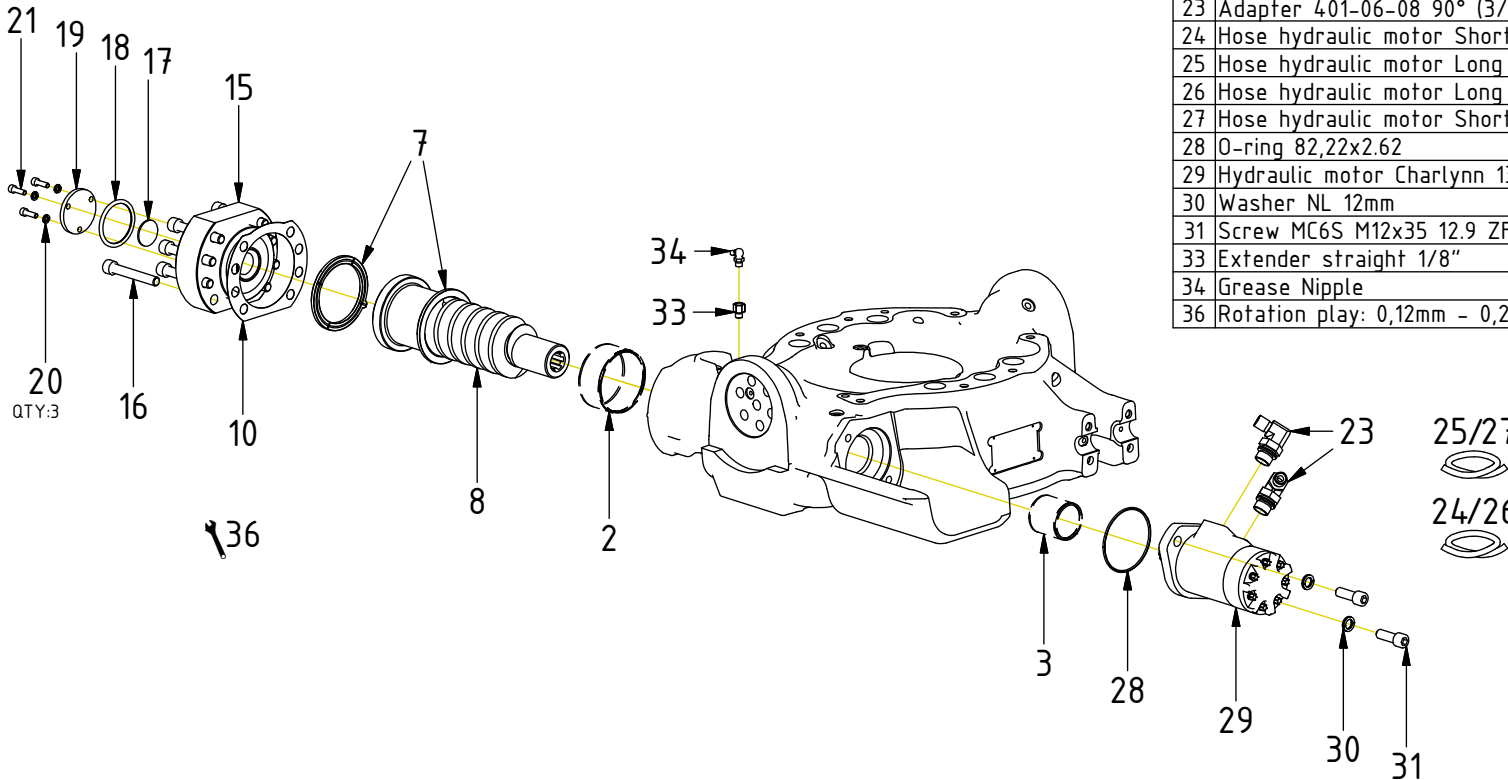
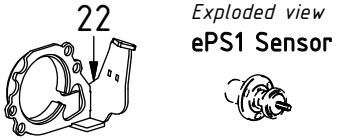

POS in order of assembly

QSM:

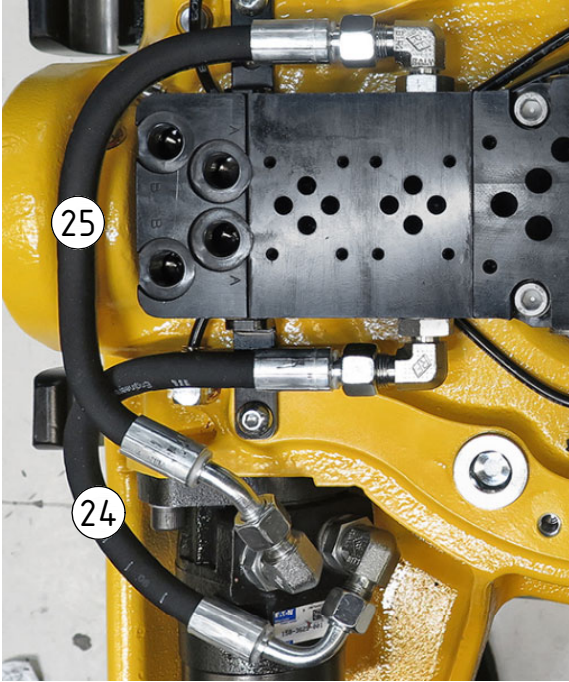

POS	DESCRIPTION	PART	QTY	COMMENTS
22	Protection ePS	1033565	1	For ePS1
24	Hose hydraulic motor Short QSM	7000789	1	Part of quick hitch
25	Hose hydraulic motor Long QSM	7000790	1	Part of quick hitch
26	Hose hydraulic motor Long ECHF	743005	1	
27	Hose hydraulic motor Short ECHF	743006	1	

ePS1:

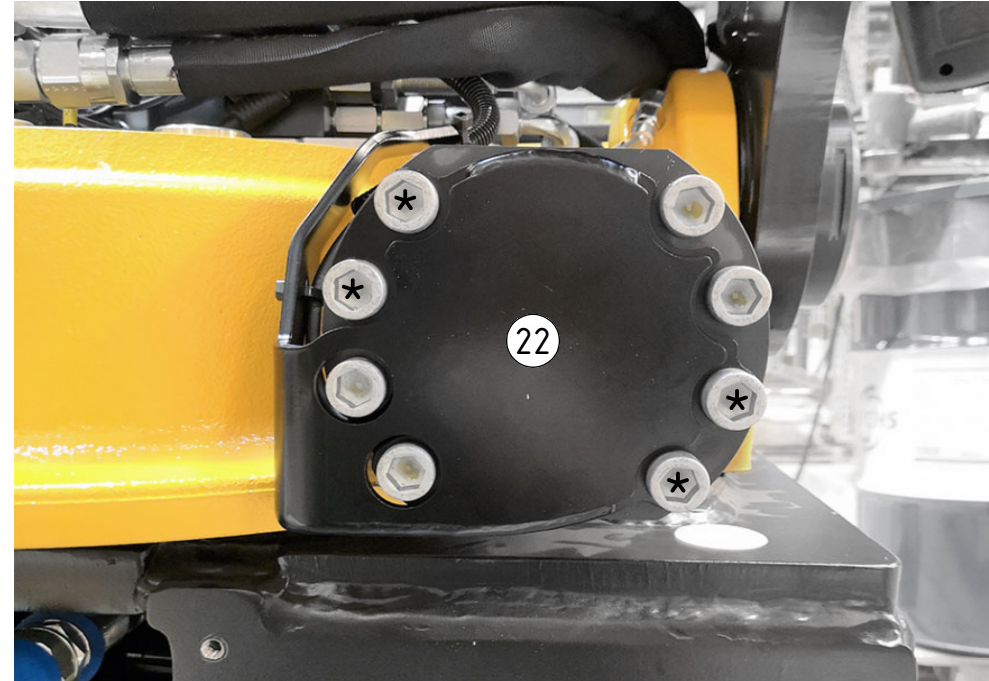

\* No torque until control system assembly

ECHF:

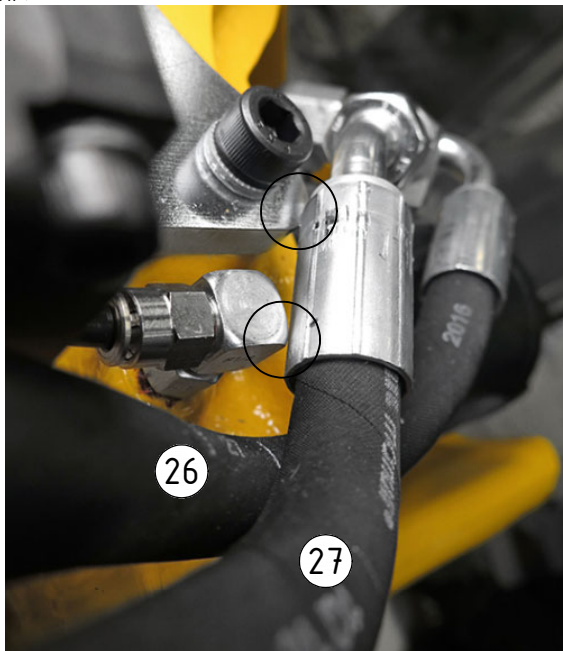
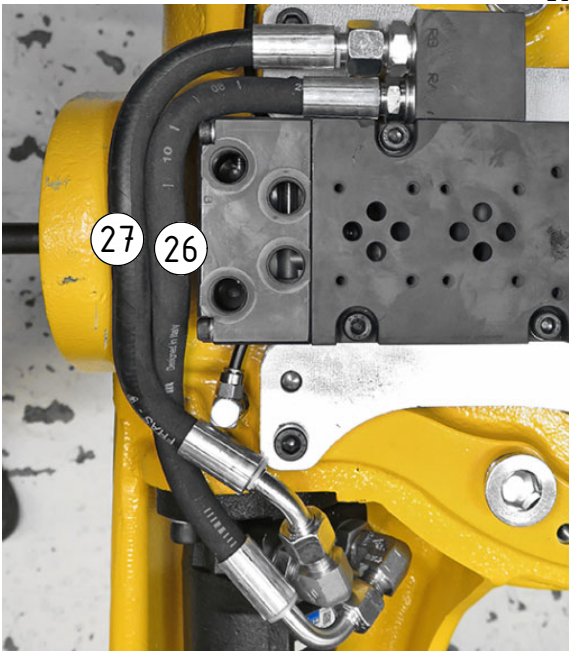

As close/tight ass possible (see the circled areas)

## SPARE PARTS

Replaced from 2024-10:

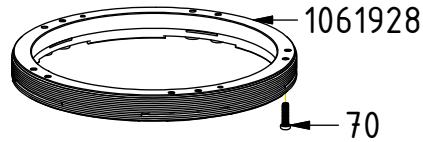

Replaced from 2022-01:

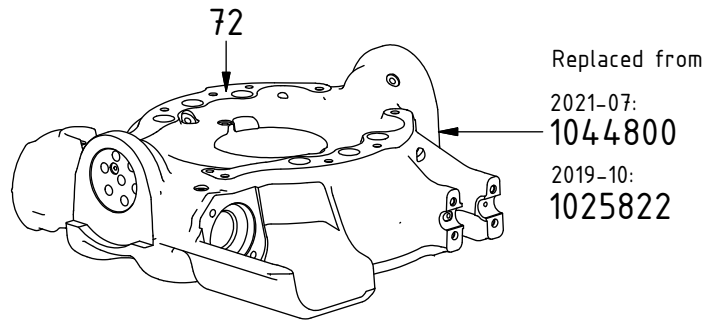
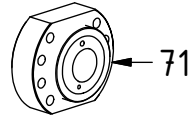

Replaced from 2018-10:

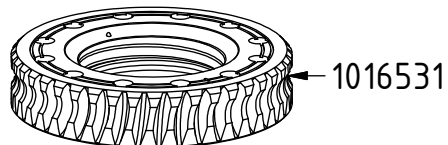

POS	DESCRIPTION	PART	QTY	COMMENTS
1	Rotator frame EC214 V3	1062446	1	(POS.2-3 incl.)
4	Worm wheel 18h EC214	1046396	1	
6	Bearing ring EC214 with steering	1077008	1	(Only compatible with 8x25)
15	End lock EC209/EC214/EC219	1016557	1	
32	Screw TX45 8x25 10,9 FZB	1078840	10	Torque: 34Nm Tighten in cross pattern
70	Screw TX45 8x30 10,9 FZB	612201	10	Torque: 34Nm. Used with 1061928
71	End lock standard & MACS	1016415	1	Replaced by POS.15 from 2022-01 MACS: Replaces 1028628 from 16-10
72	Old serial number locations			Current location found on p.2/3
73	MACS Magnet 8x5x3	6000047	1	
74	MACS Inductive sensor M8 PNP	1043698	1	Distance 3mm. Nut torque: 3Nm
75	MACS Inductive sensor M8-M12	1028045	1	Replaced by POS.74 from 2017-08 Distance 4mm. Nut torque: 3Nm
76	MACS previous pipe plug location			

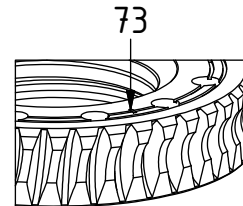

MACS:

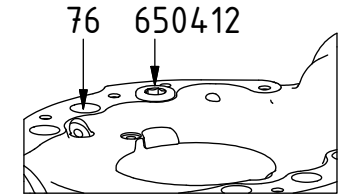
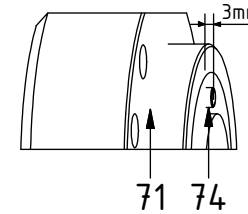

POS in order of assembly